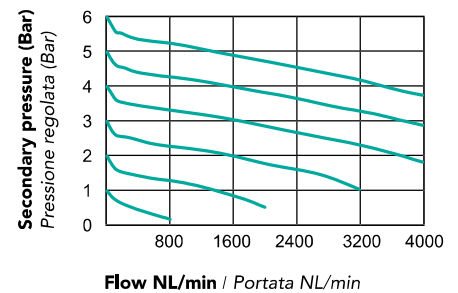
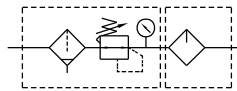

TU - FRL4H

F.R.L UNIT
UNITÀ F.R.L.

FLOW / PORTATA

Primary pressure 7 Bar
Pressione di ingresso 7 Bar*Pressure gauge to be ordered separately
*Il manometro è da ordinare a parte

TECHNICAL FEATURES / CARATTERISTICHE TECNICHE

Port size / Conessione	G 1/2"
Fluid / Fluido	Air / Aria
Operating pressure range Range di pressione operativa	0,5 ~ 15 Bar
Proof pressure Pressione di scoppio	20 Bar
Regulated pressure range Range di regolazione di pressione	10 ~ 15 Bar
Ambient temperature Temperatura ambiente	- 5 ~ +60°C (no freezing - no congelamento)
Filter element / Elemento filtrante	Standard - Standard: 40 µm Option - Opzione: 5 µm
Lubricating oil capacity / Capacità tazza olio	200 c.c.
Min. flow for oil drip Flusso minimo gocciolamento olio	80 L/min
Recommended lubricating oil Olio di lubrificazione consigliato	ISO-VG32
Attachment / Accessori	Pressure gauge Manometro
Weight / Peso	1518 g

ENCODING / CODIFICA

TU - FRL4H - 12 - M □ □

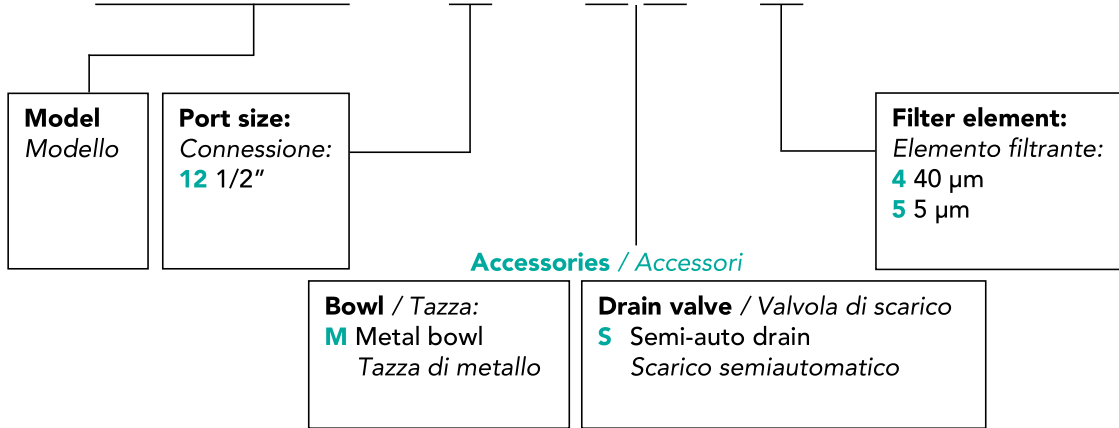

DIMENSIONS / DIMENSIONI

