



INSTALLATION, SERVICE AND MAINTENANCE INSTRUCTIONS



***Electric multi-turn actuators Rematic
with the DMS3 M1, DMS3 M2, DMS3 P1,
DMS3 P2 electronic control MOR 3PA,
MOR 3.4PA, MOR 3.5PA, MOR 4PA, MOR 5PA***

TEST CERTIFICATE

ELECTRIC MULTI-TURN ACTUATOR MOR 3PA, MOR 3.4PA, MOR 3.5PA, MOR 4PA MOR 5PA	
Type number	Power supply V Hz
Serial number	Max. load torque Nm
Production year	Switching-off torque Nm
Wiring diagram	Operating speed min ⁻¹
.....	Adjusted number of revolutions
.....	Control
.....	Input operation signal
Warranty period months	Output signal
Serial number of electric motor	
Serial number of control unit	
Tests made by	Packed by
Date	Signature and stamp

COMPLETENESS CERTIFICATE

Used valve
Assembled by: Firm
Name
Warranty period months
Date Signature and stamp.....

INSTALLATION CERTIFICATE

Location
Installed by: Firm
Name
Warranty period..... months
Date Signature and stamp.....

Please read these instructions carefully before mounting and operating the actuator!

Preventive and safety-measures applied on the actuator can not offer required safety level till the actuator and its safety systems are not applied by required and described way and if installation and maintenance is not applied according to applicable instructions and rules!

Contents

1.	General data.....	2
1.1	Purpose and applications	2
1.2	Safety instructions	2
1.2.1	Product characteristics from risk point of view.....	2
1.2.2	Product influence to environment	2
1.3	Data specified on electric actuator.....	3
1.4	Warranty conditions.....	4
1.5	Under-guarantee and after-guarantee service.....	4
1.5.1	Lifetime of actuators	4
1.6	Operation conditions.....	5
1.6.1	Product location and operation position.....	5
1.6.2	Operation Environment.....	5
1.6.3	Power supply and duty cycle	6
1.7	Description and function	7
1.8	Basic specifications	12
1.8.1	Mechanical Connection	17
1.8.2	Electric connection	18
1.9	Packing, transport, storing and unpacking.....	22
1.10	Assessment of the product and packaging and removal of contamination	22
2.	Installation and dismantling of actuator	23
2.1	Installation	23
2.1.1	Mechanical connection to the armature.....	23
2.1.2	Electric connection to the network, respectively control system	24
2.2	Dismantling.....	24
3.	Adjustment of actuator.....	25
3.1	EA control set-up options (regulating).....	29
3.1.1	Control setting possibilities for EA´s with DMS3 electronic control.....	29
3.1.2	Control setting possibilities for EA´s with DMS3 electronic control with Modbus/Profibus protocol	30
3.2	Procedure for setting individual parameters and the register of errors and warnings	31
3.3	Putting an EA into operation when the EA is set up and connected with the armature already in the manufacturer (starting the calibration).....	34
3.4	Putting an EA into operation when the parameter setting done by the producer suit to your needs.....	34
3.5	Putting an EA into operation when it is necessary to do a change to the stroke (setting new end positions), and the other parameter setting done by the producer suits to your needs	34
3.6	Setting other parameters	35
3.7	Error messages from the control unit.....	35
4.	Service, maintenance and troubleshooting.....	36
4.1	Service.....	36
4.2	Maintenance – scope and regularity	37
4.3	Troubleshooting.....	38
5.	Accessories and spare parts	40
5.1	Accessories	40
5.2	Spare part list	40
6.	Enclosures.....	41
6.1	Wiring diagrams with DMS3 electronic control	41
6.1.1	Wiring diagrams with DMS3 electronic control with Modbus/Profibus protocol.....	46
6.2	Dimension drawings and mechanic connections	50
6.2.1	Dimension drawings for EA MOR 3PA	50
6.2.2	Dimension drawings for EA MOR 3.4PA	53
6.2.3	Dimension drawings for EA MOR 3.5PA	57
6.2.4	Dimension drawings for EA MOR 5PA	61
6.3	Guarantee service check report.....	69
6.4	Post guarantee service check report	70
6.5	Commercial representation.....	71

Edition: 07/2023

The right of changes reserved!

Nr.: 74 1139 02

The Installation, Service and Maintenance Instructions are drawn up according to requirements of EC Executive Nr. 2006/42/EC "Uniform requirements for machines and devices from the point of view of safety and health care", to save life and health of users and to avoid material damages and exposure environment to danger.

1. General data

1.1 Purpose and applications

Electric multi-turn actuators **Rematic** (hereinafter referred as EA only) with the DMS 3 electronic control of the **MOR 3PA, MOR 3.4PA, MOR 3.5PA, MOR 4PA** and **MOR 5PA** type (hereinafter referred as MOR X.XPA only) are set up by the program to be controlled on the 24 V DC voltage level; are set up by the program to be controlled by analogue input signal, potentially controlled through a interface with Modbus/Profibus communication protocol.

Electric multi-turn actuators MOR X.XPA types are high-powered electric-mechanical products designed for direct installations onto controlled devices (regulating bodies - valves, etc.). EA of MOR X.XPA types are provided for remote control of closing bodies, or for automotive control of regulating bodies in both directions of their movement. They can be equipped with means of measuring and control of technological processes where an unified analogue direct current resp. voltage signal is an information bearer on their input and/or output (not valid for EA's with Modbus/Profibus protocol). They can be used in heating, energy, gas, air-conditioning and other technological systems, which they are suitable for, regarding their features. They are connected with controlled devices with a flange according to ISO 5210 or in accordance with GOST R 55510-2013.



It is forbidden to use EA as a lifting mechanism!

1.2 Safety instructions

1.2.1 Product characteristics from risk point of view



EA of MOR X.XPA types are reserved technical devices with higher rate of danger, with possibility of installation in areas specially danger regarding casualties caused by electric current.

Electric actuators are according to directive LVD 2014/35/EU and standard EN 61010-1+A1, in the edition in terms of valid certificate, assigned for installation category II (overvoltage category), pollution degree 2.

1.2.2 Product influence to environment

Electromagnetic compatibility (EMC): the product complies with the requirements of the Directive 2014/30/EU of the European Parliament and of the Council on the approximation of the laws the Member States relating to the electromagnetic compatibility and with the requirements of standards as well EN IEC 61000-6-4, EN IEC 61000-6-2, EN IEC 61000-3-2 and EN 61000-3-3+A1, in the edition in terms of valid certificate.

Vibrations caused by the product: product influence is negligible.

Noise produced by the product: The maximum allowable noise level (A) of the product measured in a place of operation is 78 dB (A) (MOR 3PA-MOR3.5PA) or 85 dB (A) (MOR 5PA).

Environment hazard: the product involves a mineral oil fill harmful for water species that is capable to generate long-time lasting adverse effects in water environment. When handling and operating the product don't allow oil to escape in environment. An increased care must be given when the product is operated near to water sources.

Requirements for professional qualification of people performing installation, service and maintenance



The electrical connection of the actuator can only be carried out by a person in accordance with legislative requirements of the given country, depending on the required areas of location/use. Service can be performed only by workers professionally qualified and trained by the producer or contracted service centre.

Warning for safety use

1. Products are assigned for operation in environment consist of gas, steam and vapours, with temperature range: -25°C to $+60^{\circ}\text{C}$ or -50°C to $+40^{\circ}\text{C}$ or -60°C to $+60^{\circ}\text{C}$, with pressure range from 0.8 to 1.1 bar.
2. If the actuator is placed on device which regulate medium with higher temperature than $+60^{\circ}\text{C}$, protect the actuator by additional construction in order to maintain ambient temperature max. $+60^{\circ}\text{C}$ and also to stop temperature transmitting through junction component!
3. Cable glands blinds are assigned only for transport and storage period, i.e. for period till the actuator is build into operation, than blinds must be replace by connecting cable.
4. In case of not using one of the cable gland, it has to be replaced with a suitable blinding plug.
5. Temperature at the point where the cables enter the actuator can reach max. 90°C . When choosing the connection cables for the actuator, it is therefore necessary to consider this temperature as well.

Product protection

There must be included suitable protective device into the supply power (circuit breaker or fuse) which serves at the same time as main switch.

EA MOR X.XPA has own short-circuit protection of motor power supply circuits and space heater. For protection, we recommend to use a fuse type "T" or a contactor type "C".

Type of equipment from a connection point of view: The equipment is designed for permanent connection.

1.3 Data specified on electric actuator

Name plate:

MOR 3PA, MOR 3.4PA, MOR 3.5PA, MOR 4PA

REGAIDA Made in Slovakia CE		N ^o <input type="text"/>		20 <input type="checkbox"/>	IP <input type="text"/>
Typ <input type="text"/>	MOT. <input type="text"/>	V <input type="text"/>	W <input type="text"/>	Hz <input type="text"/>	Ω <input type="text"/>
V <input type="text"/>	A <input type="text"/>	MAX <input type="text"/>	N.m <input type="text"/>	z <input type="text"/>	min ⁻¹ <input type="text"/>

Warning plate:









MOR 5PA

REGAIDA		TYP <input type="text"/>	N ^o <input type="text"/>
CE	Made in Slovakia	N.m <input type="text"/>	min ⁻¹ <input type="text"/>
		V <input type="text"/>	A <input type="text"/>

Name plate contains the basic data concerning identification, performance and electricity: indication of producer, type, serial number, max. load torque and switching-off torque, operating speed, protection code, revolutions, supply voltage and current.

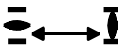
Graphic symbols on electric actuator

The graphic symbols used on electric actuator substitute the text messages. Some of them are in accordance with EN ISO 7010, ISO 7000 and IEC 60417.

	Dangerous voltage	(EN ISO 7010-W012)
	CAUTION! ¹⁾	(EN ISO 7010-W001)
	Stroke of the electric actuator	
	Switching-off torque	
	Manual control	(0096 ISO 7000)
	Protection terminal	(5019 IEC 60417)

¹⁾ See. chapter 2.1.2

1.4 Warranty conditions

The supplier is responsible for completeness of the delivery and guarantees these specifications of the product which are stated in Technical conditions (TP) or specifications agreed in the Contract.

The supplier is not responsible for any deterioration of parameters caused by the customer during storage, unauthorised installation or improper operation.

1.5 Under-guarantee and after-guarantee service

Under-guarantee service is performed by the service department of the manufacturer, or by a contracted service centre according to a written claim.

In case of occurring of any fault please let us know it and state:

- type code
- serial number
- ambient parameters (temperature, humidity...)
- duty cycle including frequency of switching
- type of switching-off (position or torque)
- set switching-off torque
- type of fault - description of claimed fault
- it is recommended to place also Installation certificate.

It is recommended to have **after-guarantee service** performed by the service department of the manufacturer, or by a contracted service centre. Serviceman makes the record about service mission after warranty actions and sends it to the manufacturer.

1.5.1 Lifetime of actuators

The lifetime of an electric actuator (EA) is at least 6 years.

EA used for closing mode (closing valves) comply with the requirements for at least **15,000 working cycles** (cycle C – O – C at 30 revolutions per operating stroke:for multi-turn EA)

EA used for regulating/modulating operation (control valves) comply with the below stated numbers of **operating hours** at the total number of 1 million start-ups:

Switching frequency				
max. 1,200 [h ⁻¹]	1,000 [h ⁻¹]	500 [h ⁻¹]	250 [h ⁻¹]	125 [h ⁻¹]
Minimal lifetime expectancy – number of operating hours				
850	1,000	2,000	4,000	8,000

Time of **net operation** is min. 200 hours, max. 2,000 hours.

Lifetime at operating hours depends on loading and switching frequency.

Note : High switching frequency does not ensure better regulation. Setting of regulation parameters should be therefore made with the inevitably necessary switching frequency needed for the process in question.

1.6 Operation conditions

1.6.1 Product location and operation position

- The assembly and operation of electric actuators according to their version can be on covered eventually open places of industrial objects without the regulation of temperature, humidity and with eventual protection against direct exposure of climate influence (e.g. direct sun shine).
- Electric actuators must be placed with access to the manual control wheel, to the cover of control box, to control box, to cable glands, resp. to local control.
- Installation and operation of actuators is possible in either position, while motor axis is in horizontal position; variance of motor axis from horizontal plane can be $\pm 15^\circ$. Common position is the one with vertical position of exit part axis and control box above. Installation EA with vertical position of motor axis is possible as well, the motor is above the control box.

Warning:



Actuator installed on the open place must be protected against a direct climate effects by shelter, mainly from sunshine.

In applications placed in an ambient of a relative moisture above 80%, in external ambient under shed, it is necessary to change the preset thermostat temperature $+25^\circ\text{C}$ to $+70^\circ\text{C}$ by a PC and program to prevent switching off the heating resistor.

1.6.2 Operation Environment

According to valid standard IEC 60 721-2-1, there are delivered these versions of electric actuators:

- 1) Version „**standard**“ for type climate temperate
- 2) Version „**tropical wet**“ for type climate tropical wet
- 3) Version „**cold**“ - for type climate cold
- 4) Version „**tropical dry and dry**“ for type climate tropical dry and dry
- 5) Version „**marine**“ for type climate marine
- 6) Version „**arctic**“ for type climate arctic.

In accordance with IEC 60 364-1, IEC 60 364-5-51 and IEC 60 364-5-55 within valid edition the EA have to resist external effects and operate reliably:

In conditions of external environment marked as:

- warm mild to hot dry with temperature -25°C to $+60^\circ\text{C}$ **AA 6+AA 7***
- cold to warm mild hot dry with temperatures -50°C to $+40^\circ\text{C}$ **AA 8***
- cold to hot dry with temperatures -60°C to $+60^\circ\text{C}$ **AA 1*+AA 6***
- with relative humidity 10 to 100 %, including the condensation of up to 0,029 kg water content per 1 kg of dry air, at above stated temperature..... **AB 6+AB 7***
- with relative humidity of 15÷100%, including the condensation of up to 0,036 kg water content per 1 kg of dry air, at above stated temperature **AB 8***
- with relative humidity of 1÷100%, including the condensation of up to 0,035 kg water content per 1 kg of dry air, at above stated temperature **AB 1+AB 6***
- with height above sea level 2 000 m, with barometric pressure range 86 to 108 kPa **AC 1***
- with spraying or jet water from all directions–(protection enclosure IP x5) **AD 5***
- with shallow dive – (product in protection IP x 7) **AD 7***
- with mild dustiness - with possibility of nonflammable effect, nonconducting and explosion-proof dust; medium layer of dust; descent of dust more than 35 but not more than 350 mg/m^2 per day (product in enclosure IP 5x)..... **AE 5***
- with strong dustiness – with a possibility of influences of inflammable, non-conducted and non-explosive dust; the middle layer of dust; the dust drop more than 350 but not more than 1000 mg/m^2 per day (products with protection enclosure of IP 6x) **AE 6***

- with atmospheric occurrence of corrosive and pollution media (with high degree of atmosphere corrosive aggressiveness); important presence of corrosive pollution **AF 2***
- with permanent exposure of big amount of corroding or contaminated chemicals and salt fog in execution for sea environment , for sewage water disposal plant and some chemical plant (not valid for EA's with local control) **AF 4***
- with a possibility of influences of mechanical stress:
 - medium sinusoid vibrations with frequency in range 10 up to 150 Hz, with shift amplitude of 0,15 mm for $f < f_p$ and acceleration amplitude $19,6 \text{ m/s}^2$ for $f > f_p$; (transition frequency f_p is from 57 up to 62 Hz) **AH 2***
 - medium impacts, shocks and vibrations **AG 2***
- with serious danger of plants and moulds growing **AK 2***
- with serious danger of animals occurrence (insects, birds, small animals) **AL 2***
- with detrimental influence of radiation:
 - of stray current with intensity of magnetic field (direct and alternating of power supply frequency) to 400 A.m^{-1} **AM 2-2***
 - of sun radiation with intensity $> 500 \text{ a } \leq 700 \text{ W/m}^2$ **AN 2***
- with effects of medium seismic activity with acceleration $> 300 \text{ Gal } \leq 600 \text{ Gal}$ **AP 3***
- with indirect danger of storm activity **AQ 2***
- with fast moving of air and strong winds **AR 3 , AS 3***
- with persons frequent touching earth potential (persons often touch conductive parts or they stand on the conductive basement) **BC 3***
- without any danger media with object **BE 1***

* Marking in accordance with IEC 60364-1, IEC 60 364-5-51 and IEC 60 364-5-55 within valid edition

1.6.3 Power supply and duty cycle

Power supply:

electric motor Y/Δ ; 400 / 230V AC resp. Y/Δ ; 380 / 220V AC $\pm 10\%$ (other - after agreement with manufacturer)

control binary inputs 24 V DC $\pm 10\%$

input control signal 0/4/12 to 20 mA, 4 to 12 mA resp. 20 to 0/4/12 mA, 12 to 4 mA,

or 0/2 to 10 V, resp. 10 to 0/2 V

electronic positional transmitter (EPV) without power supply (passive) 18 up to 30 V DC $\pm 10\%$

communication protocol (by version)..... Modbus (either single Channel or duo Channel)

..... Profibus (either single Channel or duo Channel)

Frequency of power supply 50/60* Hz (MOR 3PA-MOR 3.5PA), 50 Hz (MOR 5PA) $\pm 2\%$

* At frequency of 60 Hz operating speed increased by 1, 2 multiple.

Duty cycle (according to EN 60034-1,8 (IEC 60034-1, 8)):

EA MOR X.XPA designed for remote control are designed for :

- short-time operation **S2-15 min**
- intermitted operation **S4-25%, 6 up to 90 cycles per hour**

EA MOR X.XPA designed for **automatic regulation** via analogue signals are designed for :

- intermitted operation S4-25% with min. number of starts according to the following table:

Rated torque ranges [Nm]	Modulating with reverse contactors [starts per hour]	Continuous modulating with contactless switching [starts per hour]
do 100	1200	3600
101-700	600	1800
701-2500	300	600

1.7 Description and function

EA MOR X.XPA are of compact construction with several connected modules. They are composed of two functionally different main parts consisting of following modules (Fig.1):

Power part -	Module M1	– electric motor
	Module M11	– countershaft transmission with rotating bief
	Module M3	– power transmission with manual control (MOR 3PA, MOR 4PA and MOR 5PA) and power transmission with manual control and with additional gear box (MOR 3.4PA and MOR 3.5PA)
Control part -	Module M4	– control box

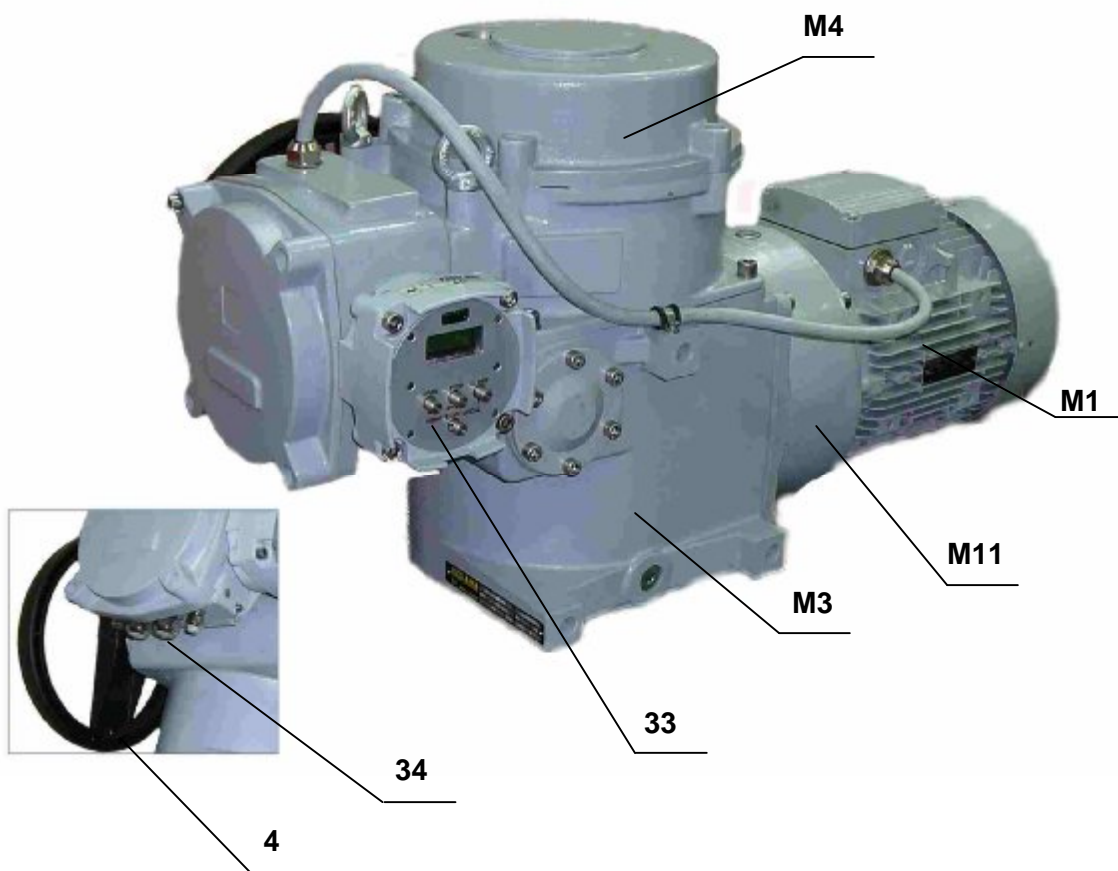

Fig.1 – MOR X.XPA

Module M1 – electric-motor

- Three-phase asynchronous electric-motor

Module M11 – countershaft transmission with rotary hold

Countershaft transmission performs reduction of revolutions of electric - motor to specified transmission value. Countershaft transmission consists of two or three pairs (MOR 3PA, MOR 3.4PA, MOR 3.5PA, MOR 4PA) resp. of one or two pairs (MOR 5PA) of spur meshing toothed wheels and is terminated by bevel pinion, which meshes into bevel gear of transmission from module M3.

Rotary hold substitutes motor mechanic brake and allows manual control of EA.

Modul M 3 – force transmission with manual control (Fig. 2)

The set is stored in box (1). Gears are centrally positioned on output shaft (3) and creates independent assembly unit. Wheel rim (44) with inner gearing provides transfer between electric motor pinion and output shaft. In upper part is located the warm (2) for torque sensing and manual control, which is used for positioning of controlled equipment during electric power breakdown. Positioning is executed manually by hand wheel (4). The warm is suspended and a thrust created by output shaft

torque axially shifts the worm against spring tension. The worm movement is transferred by the fork with pin through a shaft (45) joined to control box. Movement of the worm is proportional to the load torque. The fork meshes into circumferential notch, allowing rotary motion of manual wheel, therefore manual control in every operating status. On the box (1), (across to manual wheel) are three bosses with threaded openings allowing assembly of electric actuator on the wall, or supporting construction.

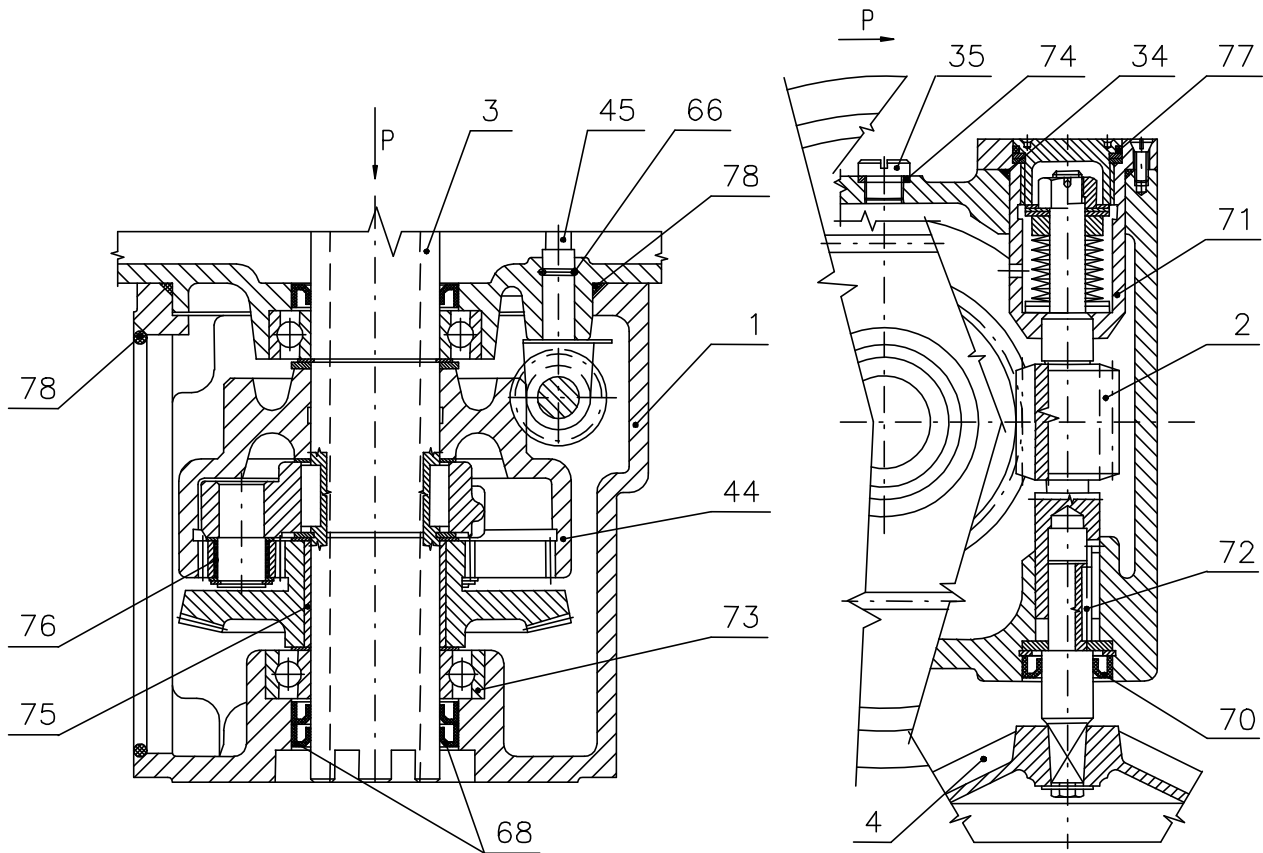

Fig. 2

Module M 4 – control box (Fig. 1)

Control box is in upper part of electric actuator and forms individual function unit. The top part is formed by the cover with opening and monitoring window of position indicator.

The bottom part of control box closes the box of force transmission and forms carrying part of control plate Fig.3 and 3a.

On mounting base (8) of control plate are fixed these functional blocks:

- power supply board (9)
- control unit of the electronics DMS3 (10)
- position sensing unit (11)
- torque sensing unit (12)
- thyristor unit or reversing contactors (13)
- space heater (14)
- transformer (15)
- LED display (16) (in version without manual control)

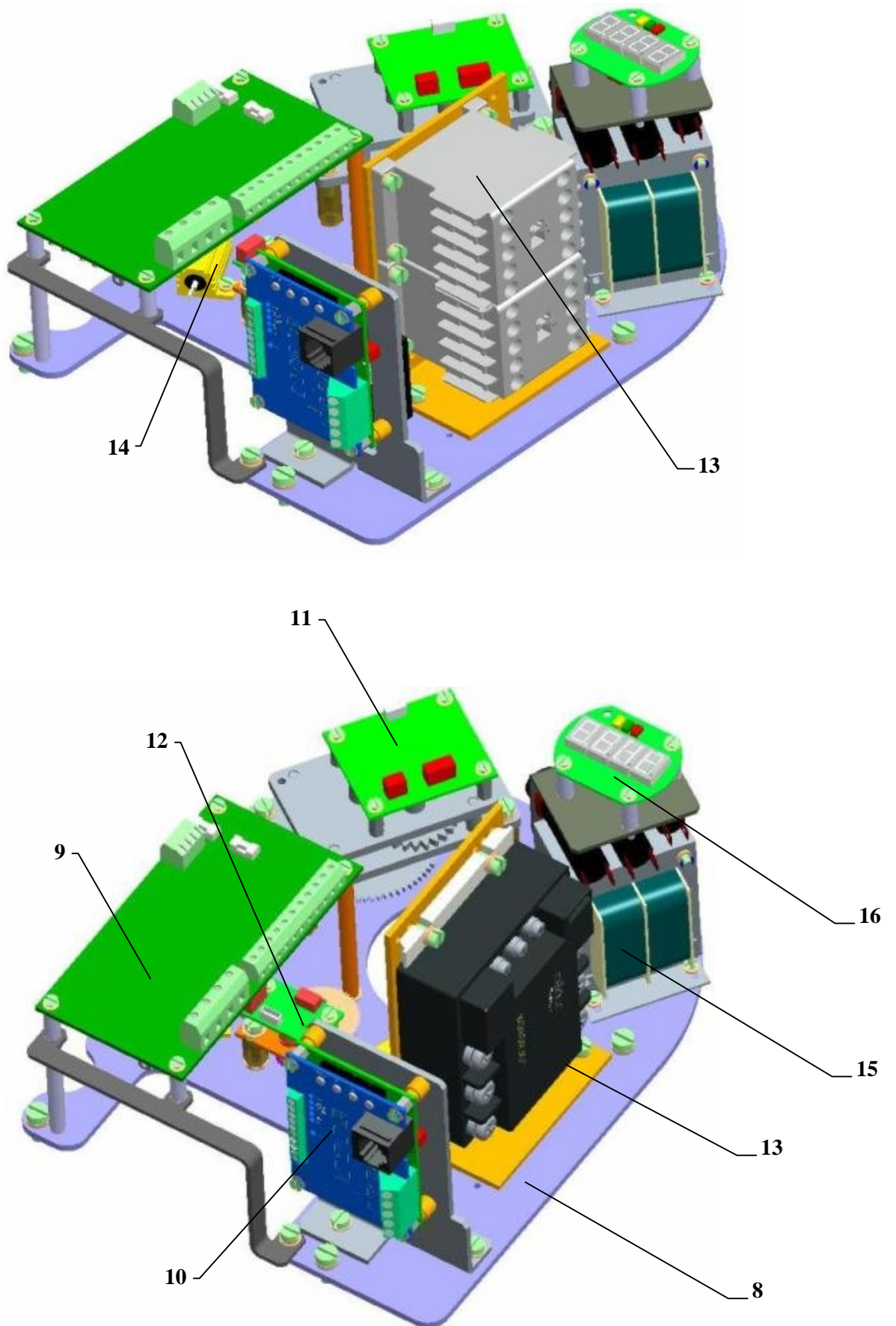

Fig.3 - MOR 3PA, MOR 3.4 PA, MOR 3.5PA, MOR 4PA

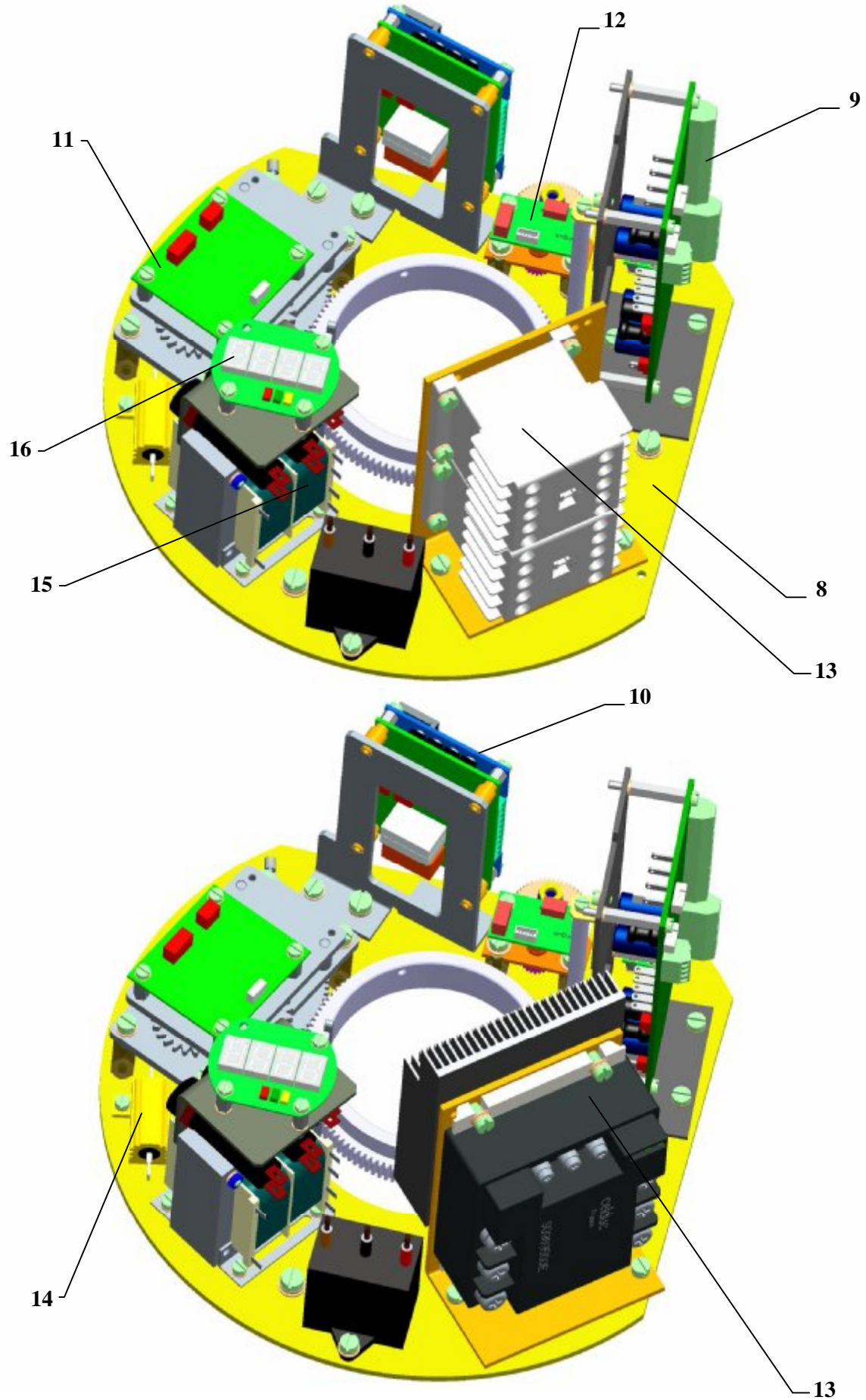

Fig.3a - MOR 5PA

The **MOR X.XPA** electric actuator is controlled according to version

- by 24 V DC voltage fed to the electric actuator's terminals according to the wiring diagram or by 0/4/12 to 20 mA, 4 to 12 mA resp. 20 to 0/4/12 mA, 12 to 4 mA, (0/2 to 10 V resp. 10 to 0/2 V)
- input control signal and provides for moving the output part of the EA automatically to a position corresponding to the value of the input signal, and other functions as well.
- through Modbus res. Profibus communication interface.

The electric actuator consists of these main parts **(1,2,3,3a)**:

The electric actuator is driven by an **electric motor (M1) (fig.1)** supplied from the **power supply board (9)** (fig.3, 3a) and **control unit (10)** (fig.3,3a) of the DMS3 electronics.

Position of output element of EA and torque are scanned by contactless absolute sensor.

Depending on the version, the DMS3 electronic circuit board may include **an electronic position transmitter (EPV)** without power supply (passive) with output signal 4 - 20 mA.

Space heater (14) (fig.3,3a) is placed at the mounting base (8) (fig.3,3a).

In case of power cut or damage of switches the actuator can be controlled manually according to instructions stated in chapter 1.9 Basic specifications and in chapter 4.1 Service.

Basic modules of DMS3 electronic control system for MOR X.XPA:

Control unit (10) (fig.3,3a) – main part of system DMS3 – it contains microprocessor, 6 signal LED and 4 buttons for simple adjustment and control of EA, connectors for connection of torque scanner and sourcing board and communication connector (connection to PC for adjustment and diagnostic), according to version 2 free programmable relays R1 and R 2, 1 relay READY and terminals for electric connection.

Supply board for 3-phases version (9) (pic. 3,3a) – is powered from the transformer (15) (pic. 3, 3a) and offers to the user output voltage 24 V DC, max. 100mA. The user relays READY, RE1 to RE5 are part of the supply board. The supply board gives the output to the space heater and also to control of reverse contactors coils eventually to the contactless motor switch. The supply board contains user terminal board and connector for wiring with control box.

Position sensing unit (11) (fig.3, 3a) – secures contactless magnetic position sensing of output element.

Torque sensing unit (12) (fig.3, 3a) – provides contactless magnetic torque reading.

Switching unit three - phase electric motors – reversing relays, contactors or contactless switching (SSR).

LED display (16) (fig.3, 3a) – shows instant position of EA output member and reports and displays potential errors, which would occur when EA is operated. Signalling motion and failure of the EA is also indicated by LEDs diode. LED display is used only pro type of construction EA without local control.

Manual control: made up by a handwheel with a worm gearing (4) (fig.1).

Other accessories – as optional accessories:

- Local electric control module equipped with a 2-line LCD display (33) (fig.1) resp. (fig. 7).

1.8 Basic specifications

Basic EA specifications:

Operating speed [min^{-1}], operating stroke [revolutions], switching-off torque [Nm] and electric motor parameters are given in Table Nr. 1 and in Table Nr. 1a.

Table Nr. 1 Basic EA MOR 3PA specifications:

Type/type number	Operating speed $\pm 10\%$	Number of revolutions ³⁾	Max. load torque		Max. switching - off torque ¹⁾ $\pm 10\%$	Weight	Electric motor					
			ON-OFF duty S2-15 min.	Modulating duty S4-25%			Supply voltage	Nominal power	Nominal speed	Nominal current ²⁾		
	[min^{-1}]	[revolutions]	[Nm]	[Nm]	[Nm]	[kg]		[V] $\pm 10\%$	[W]	[1/min]	[A]	
1	2	3	4	5	6	7	8	9	10	11	12	
MO 3PA Type number 094	10	1 - 1000	24	16	40	cca 26,5 to 34,5	Three - phase	Y / Δ ; 380 / 220; 50 Hz Y / Δ ; 400 / 230; 50 Hz	180	850	0,72	
			54	36	90							
			80	50	130							
			90	60	150							
	16		24	16	40				120	1350	0,42	
			54	36	90							
			80	50	130							
			90	60	150							
	25		24	16	40				370	1370	1,06	
			54	36	90							
			80	50	130							
			120	80	200							
	40		24	16	40				180	1350	0,58	
			54	36	90							
			90	60	150							
			120	80	200							
	50		24	16	40				250	1350	0,77	
			54	36	90							
			90	60	150							
			120	80	200							
	60		48	-	80				370	1370	1,06	
			54	-	90							
			90	-	150							
			120	80	200							
63	24	-	40	600	1340	1,64						
	38	-	63									
90	24	-	40	250	1350	0,77						
	48	-	80									
95	48	-	80	370	1370	1,06						
	120	-	150									
								1450	2820	3,30		

Next page>>>>>>

Table Nr.1 - Basic technical data of EA MOR 3.4PA, MOR 3.5PA, MOR 4PA											
Type/ type number	Control speed ±10[%]	Number of revolu- tions ³⁾	Max. load torque		Max. switching - off torque ¹⁾ ±10 [%]	Weight	Electric motor				
			ON-OFF duty S2-15 min.	Modulating duty S4-25%			Supply voltage	Nominal			
								power	speed	current ²⁾	
	[min ⁻¹]	[revolution]	[Nm]	[Nm]	[Nm]	[kg]		[V] ±10%	[W]	[1/min]	[A]
1	2	3	4	5	6	7	8	9	10	11	12
MOR 3.4PA Type number 106	10	1 - 500	120	80	200	cca 42 ± 5%	Three - phase	Y / Δ; 380 / 220; 50 Hz Y / Δ; 400 / 230; 50 Hz	250	829	0,79
			180	120	300				370	1369	1,06
			210	140	350				550	910	1,60
	108		72	180	370				1369	1,06	
	120		80	200	550				910	1,60	
	150		100	250	750				1395	1,91	
	210		140	350	550				1395	1,46	
	90		60	150	750				1395	1,91	
	120		80	200	1500				2890	2,95	
	150		100	250	750				2854	1,73	
	210		140	350	1500				2890	2,95	
	100		70	170	1100				2845	2,40	
	120		80	200	1500				2890	2,95	
	180		120	300							
	150		-	150							
	180		-	300							
	120		-	200							
	150		-	250							
MOR 3.5PA Type number 096	25	1 - 400	84	56	140	cca 49 ± 5%	Three - phase	Y / Δ; 380 / 220; 50 Hz Y / Δ; 400 / 230; 50 Hz	940	2735	2,30
			200	130	320				1450	2820	3,3
			270	180	450				940	2735	2,3
	330		220	550	1450				2820	3,3	
	84		56	140	940				2735	2,3	
	200		130	320	1450				2820	3,3	
	270		180	450	940				2735	2,3	
	320		220	530	1450				2820	3,3	
	84		56	140	940				2735	2,3	
	160		100	260	1450				2820	3,3	
	200		130	320							
	230		150	380							
MOR 4PA Type number 157	10	1-1000				cca 41,5± 5%	Three - phase	Y / Δ; 380 / 220; 50 Hz Y / Δ; 400 / 230; 50 Hz	370	919	1,2
	16		550	1395	1,46						
	25		750	1395	1,91						

Table Nr.1a - Basic technical data of EA MOR 5PA											
Type/type number	Operating speed ±10[%]	Number of revolutions ³⁾	Max. load torque		Max. switching - off torque ¹⁾ ±10 [%]	Weight	Electric motor				
			ON-OFF duty S2-15 min.	Modulating duty S4-25%			Supply voltage	Nominal			
								power	speed	current ²⁾	
	[min ⁻¹]	[revolutions]	[Nm]		[Nm]	[kg]	[V] ±10 [%]	[kW]	[1/min]	[A]	
1	2	3	5		6	7	8	9	10	11	12
MOR 5PA / Type number 158	15	1 to 800	300	200	500	93,5 to 103	Three - phase	Y / Δ; 380 / 220; 50 Hz Y / Δ; 400 / 230; 50 Hz	1,1	680	2,9
			380	250	630				1,5	705	3,9
			600	400	1000				1,5	925	3,9
	20		300	200	500				2,2	940	5,2
			380	250	630				2,2	1420	4,7
			600	400	1000						6,4
	40		300	200	500				2,2	1420	4,7
			380	250	630				3		6,4
			600	400	1000				2,2		4,7
	60		300	-	500				3	1440	6,4
			380	-	630				4		8,2
			600	-	1000				3		6,4
	100	300	-	500	4				1440	8,2	
		380	-	630	3					6,4	

Remarks:

- 1) State the switching - off torque in your order by words. If not stated it is adjusted to the maximum rate of the corresponding range. Starting torque is min. 1, 3 multiple of maximum switching-off torque of selected range.
- 2) Applies to voltage 3x400V AC.
- 3) State individual number of working revolutions in the order. Provided customer doesn't specify otherwise, EA will be set on 20 working revolutions.
- 4) The total current of EA is the sum of the electronics current (0.15 A) and the electric motor current according to the EA version.

Other specifications:

EA protection enclosure:IP 55 resp. IP 67

Mechanical ruggedness:

sinusoid vibrationssee Chapter 1.7.2
resistance by drops 300 drops with acceleration of 5 m.s⁻²

Self-locking: guaranteed within 0% till 100% switching - off torque

Electric motor protection: termistor PTC

Electric control:

remote control - movement of output part of the electric actuator is controlled :

- by binary inputs 24 V DC, or
- by unified input signal 0/4/12 to 20 mA, 4 to 12 mA resp. 20 to 0/4/12 mA, 12 to 4 mA (0/2 to 10 V resp. 10 to 0/2 V), according to version.
- potentially controlled through a interface with Modbus/Profibus communication protocol

Power supply of electronics:

Power supply DMS3 Z3 is used for three phase versions and feeds the electronic modules built in EA. It provides the 24V DC, 100 mA output voltage according to version.

Power sources contain a protective fuse with parameters according to chapter 1.9.2 Electric connection.

Position sensing:

- contactless absolute magnetic.

End positions adjustment:

End position relays are preset to a specified working stroke. It is possible to set up (with keys situated on the control unit or through with keys situated on the electric local control, resp. program after connecting the EA with PC) the switching-off in end positions as follows:

- C = Torque + O = Torque
- C = Torque + O = Position
- C = Position + O = Torque
- C = Position + O = Position

Notes:

C = Torque - shutting off at end limit - torque „Closed“

O = Torque - shutting off at end limit - torque „Opened“

C = Position - shutting off at end limit - position „Closed “

O = Position - shutting off at end limit - position „Opened“

Factory's setup of switching-off in end positions is described in the chapter 3 "Adjusting of actuator".

Torque sensing:

- contactless absolute magnetic

Disengaging torque adjusting:

Disengaging torque is factory adjusting to a maximum value with the $\pm 10\%$ tolerance shown on the name plate of the appropriate EA.

The user is allowed to modify the switching-off torque value within the range 50 - 100%, stepped by 10%.

Torque blocking:

The switching-off from torque can be blocked within a certain range of the stroke starting from a stroke end position (max.5%), for time agreed on, in range of 0 to 20 sec..

Output relay (according to version) :

- 3x relays (standard for DMS3 without version Modbus/Profibus) (**READY, R1, R2**) max.

250 V AC/1 A/cos phi=1; max. 30 V DC/2A

- relays **READY, RE1, RE2, RE3, RE4 and RE5** are free programmable (their function can be changed with buttons on the control unit, with buttons on the electric local control, or through a PC with the program).

READY relay: - programme selections option – error indication, error or warning, error or not remote, error or warning or not remote. READY relay factory set is shown in the chapter 3 "Adjusting of actuator". Relay READY on the control unit and supply unit are doubled (it is not possible to set different functions on these units)

R1, R2, RE1, RE2, RE3, RE4 and RE5 relay: - programme selections option – disabled, Position O (position open), Position C (position close), Torque O (torque open), Torque C (torque close), Torque O or Torque C, Torque O or Position O, Torque C or Position C, opens, closes, movement, movement – flasher, to position, from position, warning, control – remote, control – local, (not valid for EA's without local control), control OFF.

Relay R1 is doubled with relay RE1 and relay R2 is doubled with relay RE2. Individual relay factory set is shown in the chapter 3 "Adjusting of actuator".

Transmitter (output signal) (not valid for Modbus/Profibus version)**Electronic position transmitter (EPV) passive - 2-wire connection** (without inbuilt power supply)

Current signal.....	4 ÷ 20, resp. 20 ÷ 4 mA (DC)
Voltage at connection of EPV passive	18 up to 30 V DC
Load resistance	max. $R_L = 500 \Omega$
Tolerance of value of output signal of electronic transmitter in end positions:	$\pm 0,5 \%^{1)}$
Tolerance of linearity of transmitter.....	$\pm 1 [\%]^{1)}$
Hysteresis of transmitter	max. 1 $[\%]^{1)}$

1) from nominal value of transmitter referred to output values

Galvanic separation..... output signal is galvanically separated from input control signal

Program possibilities of output signal (N) : 4 ÷ 20 mA, 20 ÷ 4 mA . Factory's setup of output signal is described in the chapter 3 "Adjusting of actuator".

Electronic position controller (N) (not valid for Modbus/Profibus version)– actuation by input control signal

Input control signals - analogue:	0 - 20 mA (0 – 10 V by version)
.....	4 - 20 mA (2 – 10 V by version)
.....	12 - 20 mA
.....	4 - 12 mA
.....	20 - 0 mA (10 – 0 V by version)
.....	20 - 4 mA (10 – 2 V by version)
.....	20 - 12 mA
.....	12 - 4 mA

Input resistance for signal 0/4/12 to 20 mA. 4 to 12 mA and 20 to 0/4/12 mA, 12 to 4 mA : $R_{in} = 120 \Omega$

Input resistance for signal 0/2 to 10 V and 10V to 0/2 V: $R_{in} = 30 k\Omega$

Tolerance of controller's linearity: 0,5 %

Dead of controller: 1 – 10 % - (adjustable)

Factory's setup of input signal is described in the chapter 3 "Adjusting of actuator".

Version with Modbus interface:

- Modbus, line specification: RS485, two-wire design, half duplex.
- Modbus, Transmission Mode: RTU (8-bit binary data).
- Variants:
 - Single Channel version with cable or component redundancy or with repeater (common address and communication parameters).
 - Duo Channel version with cable or component redundancy or with repeater (common address and communication parameters).
- Address: 1 through 247
- Parity:
 - Even (1 stop bit)
 - Odd (1 stop bit)
 - No (2 stop bits)
- Supported transmission rates:
 - 300 bit/s
 - 600 bit/s
 - 1200 bit/s
 - 2400 bit/s
 - 4800 bit/s
 - 9600 bit/s
 - 19200 bit/s
 - 38400 bit/s
 - 57600 bit/s
 - 115200 bit/s
- Signal delay (repeater):
 - max. 2.67 μs
- Bit edge reduction/extension (repeater):
 - max. 1.67 μs

Version with Profibus interface:

- Profibus, line specification: two-wire design, galvanic separated.
- Variants:
 - Single Channel version.
 - Duo Channel version (simple/redundancy).
- Address 1: 1126
- Address 2: 1126
- Redundancy:
 - Off (for single channel version)
 - Simple (for duo channel version)
- Supported transmission rates:
 - 9,6 kbit/s
 - 19,2 kbit/s
 - 93,75 kbit/s
 - 187,5 kbit/s
 - 500 kbit/s
 - 1500 kbit/s

Control by binary inputs 24 V DC:

by feeding of **24 V DC** to terminals **CLOSE** and **OPEN**.

Programming possibilities of binary inputs I1 and I2 (change is possible only through the programme of PC or using buttons local control)

- for the input **I1** : DISABLED; ESD; DBL (local releasing, remote releasing - not valid for this type of the EA); STOP

- for the input **I2**: DISABLED; ESD; DBL (local releasing, remote releasing - not valid for this type of the EA); 2P resp. E2P (the EA can undergo control for the opening direction or closing with the controller ON and I2 input activated with 24 V DC voltage supplied to the terminals to OPEN or CLOSE).

Factory's setup is described in the chapter 3 "Adjusting of actuator".

Programmable FAILURE REACTION: OPEN, CLOSE, STOP, SAFE POSITION

Factory's setup is described in the chapter 3 "Adjusting of actuator".

Adjustable elements :

The EA is possible to adjust with or resetting to different parameters operating the control unit buttons, local control buttons (following the version) or once it is connected to the PC using the programme and the communication cable connected to the EA control unit communication connector and the EA cover removed.

Space heater (E1)

Space heater - supply voltage:..... cca 18 V AC

Space heater power output: cca 10 W/55°C

Electronic board provides switching of heating element. It is possible to change switching temperatures of the switch from -40°C to +70°C with help of PC and particular software. Factory's setup for shut down of heating element (thermostat) is +25°C.

Manual control:

By hand wheel; after releasing of locking screw even during operation of the electric motor. By rotation of hand wheel clockwise is electric actuator output shaft shifted towards „close“.

Number of revolutions of manual hand wheel for 1 output revolution 26 (MOR 3PA), 62 (MOR 3.4PA), 95,5 (MOR 3.5PA) and 31 (MOR 5PA).

Output part backlash: < 5 ° (at 5 % of switching torque)

Grease: see chapter 4.2 Maintenance - extent and periodicity.

1.8.1 Mechanical Connection

- with flanges ISO 5210, NON-STANDARD resp. GOST R 55510-2013.
- Main and connecting dimensions are given in the **dimensional drawings**.

1.8.2 Electric connection

MOR 3PA, MOR 3.4PA, MO 3.5PA, MOR 4PA for DMS 3 electronic control

To the terminal board (X, X1, X2):

- 4 terminals (PE, U, V, W) on the power supply board with cross-section of connection wire 0,05 - 2,5 mm² for solid wire and for flexible wire. Max. terminal screw tightening torque 0,5 N.m
- 4 terminals (2x0 V,+24 V) with cross-section of connection wire 0,05 - 1 mm². Max. terminal screw tightening torque 0,19 N.m.
- 5 terminals (COM, NO, NC, R1, R2) for relay READY, R1 and R2 on the control unit with cross-section of connection wire 0,05 – 1,5 mm² for solid wire and for flexible wire. Max. terminal screw tightening torque 0,5 N.m
- 10 terminals (COM, CLOSE, OPEN, I1, I2, +IN,-IN,SH,+L,-L) on the control unit with cross-section of connection wire 0,05 – 1 mm² for solid wire and for flexible wire. Max. terminal screw tightening torque 0,19 N.m.
- 11 terminals (COM, NO, NC, COM1, RE1, RE2, RE3, RE4, COM5, NO, NC) for relay READY, RE1, RE2, RE3, RE4, RE5 on power supply board with cross-section of connection wire 0,05 – 1,5 mm² for solid wire and for flexible wire. Max. terminal screw tightening torque 0,5 N.m.

MOR 5PA for DMS 3 and for DMS3 electronic control with Modbus/Profibus protocol

- max. 34 terminals with cross-section of connection wire 0,08 - 2,5 mm².

MOR 3PA, MOR 3.4PA, MO 3.5PA, MOR 4PA for DMS3 electronic control with Modbus/Profibus protocol

- max. 34 terminals with cross-section of connection wire 0,08 - 2,5 mm².

Attention: Thermic resistance incoming wires must be minimum +80°C.

Wire cross-section conversion table (mm ² – AWG)	
Wire cross-section	
mm ²	AWG
0,05	30
0,2	24
0,34	22
0,5	20
0,75	18
1,5	16
2,5	14

Tightening torque conversion table (N.m – lbs.-in)	
Tightening torque	
N.m	lbs.-in
0,2	2,7
0,3	4
0,5	7

Cable glands for EA MOR 3PA, MOR 3.4PA, MO 3.5PA, MOR 4PA with DMS3 electronic control:

2 cable glands M25x1,5 from control box – diameter of cable 12,5 to 19 mm.

Cable glands for EA MOR 5PA with DMS3 electronic control:

2-cable cable glands M25x1,5 from control box - diameter of cable 12,5 to 19 mm

1-cable cable gland M16x1,5 from control box - diameter of cable 6 to 10,5 mm.

Cable glands for EA MOR 3PA, MOR 3.4PA, MO 3.5PA, MOR 4PA, MOR 5PA with the DMS 3 electronic control with Modbus/Profibus protocol

- 2 cable glands M25x1,5 from control box, diameter of cable 12,5 to 19 mm
- 1 cable glands M16x1,5 from control box, diameter of cable 6 to 10,5 mm
- 2 resp. 4 cable glands EMC M16x1,5 - cable diameter 6,5 to 9,5 mm, diameter of shielding 2,5 to 6 mm.

Protection terminal:

During start-up - during installation of device:



- for safety operation of the actuator use EA be unavoidable connect external and internal ground terminal. The position of the external and internal ground terminal according to version EA can be seen in fig. 4 and fig.4a. For forcing - in wires in external ground terminal be needed use pliers HP3 for insulated eyelet (firm CEMBRE).

- a switch / circuit breaker must be installed on the power supply line, as close as possible to the device, easily accessible to operators and identified as the actuator isolation switch.

External and internal, are together connected and marked with the mark of protection grounding. The electric connection should be made according to wiring diagrams pasted into the upper cover resp. terminals box of the EA.

MOR 3PA, MOR 3.4PA, MOR 3.5PA, MOR 4PA for DMS3 **electronic control:**

INTERNAL
PROTECTION
TERMINAL

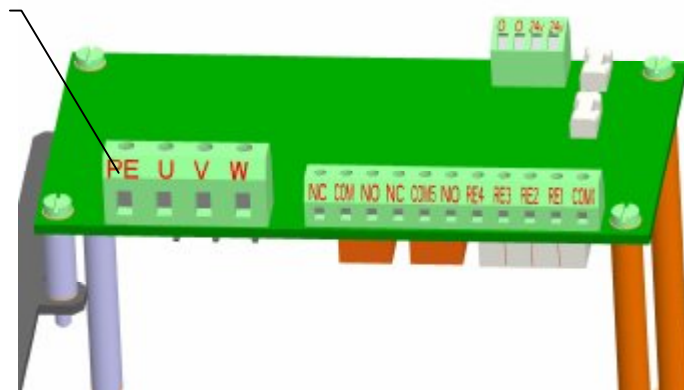

EXTERNAL
PROTECTION
TERMINAL



Fig.4

MOR 5PA for DMS 3 electronic control and MOR 3PA, MOR 3.4PA, MOR 3.5PA, MOR 4PA, MOR for DMS 3 electronic control with Modbus/Profibus protocol

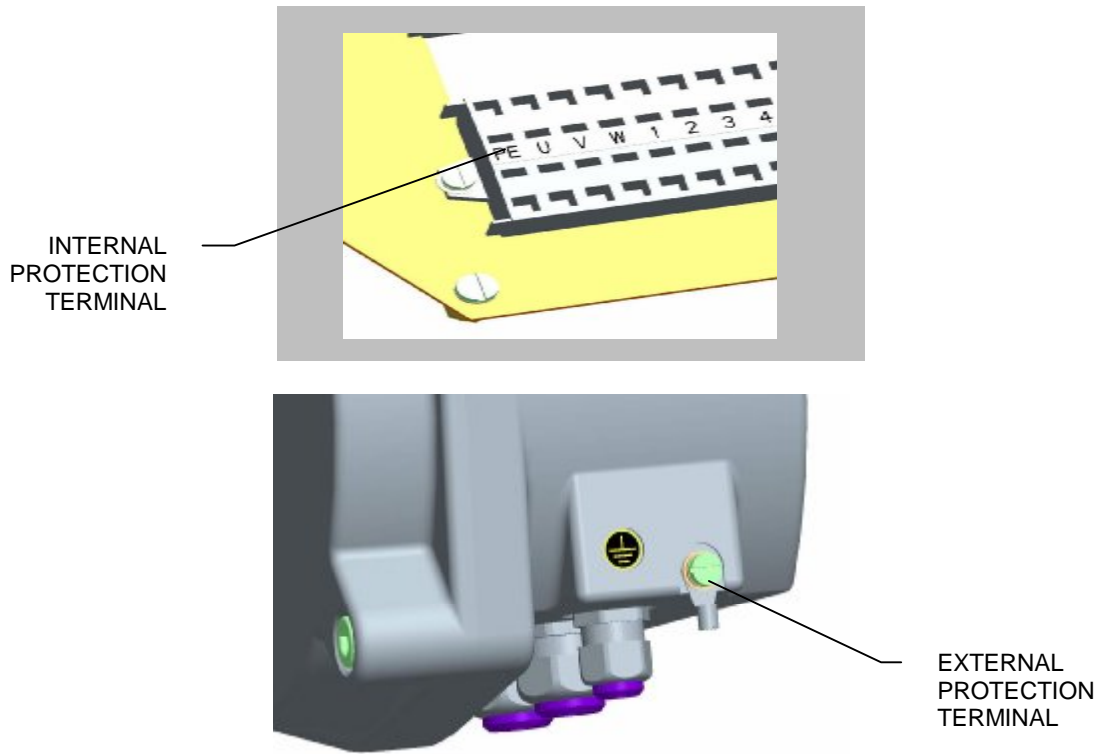

Fig.4a

Fuses:

Power supply board of actuator is equipped with fuses F3 and F4. Location of the fuse on the power supply board can be seen in Fig.5.

Fuses values and parameters:

	FUSES	F3	F4	F5	F6	F7-1	F7-2
MOR 3PA MOR 3.4PA MOR 3.5PA MOR 4PA	SIZE	Automatic reset fuse as short-circuit protection for external supply for customer	NANO ² SMD	5x20mm	5x20mm	6,3x32mm	
	WITH REVERSING CONTACTORS		1A T 125 V	0,4A F 250 V	1A F 250 V	-	
	WITH THYRISTORS		1A T 125 V	0,4A F 250 V	1A F 250 V	10A FF 500 V	
MOR 5PA	SIZE		NANO ² SMD	5x20mm	5x20mm	6,3x32mm	
	WITH REVERSING CONTACTORS		1A T 125 V	0,4A F 250 V	1A F 250 V	-	
	WITH THYRISTORS		1A T 125 V	0,4A F 250 V	1A F 250 V	20A FF 500 V	

- F3 - fuse external power supply for the customer
- F4 - fuse of space heating
- F5 - fuse the secondary (10 V AC) transformer
- F5 - fuse the secondary (18 V AC) transformer
- F7 - fuse thyristor module

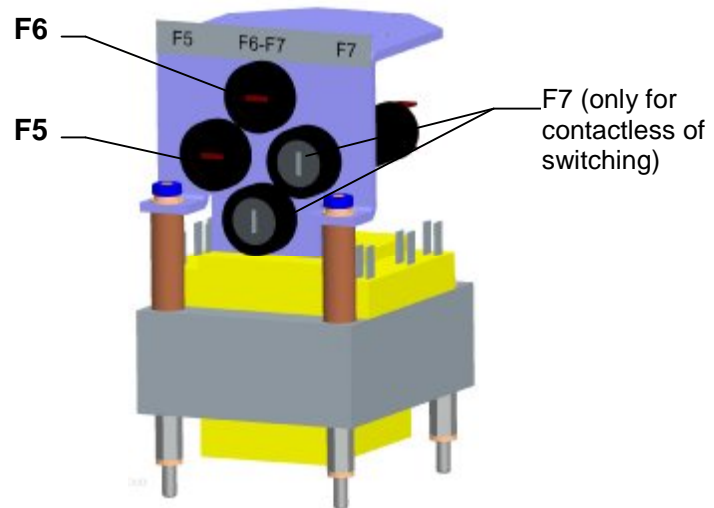
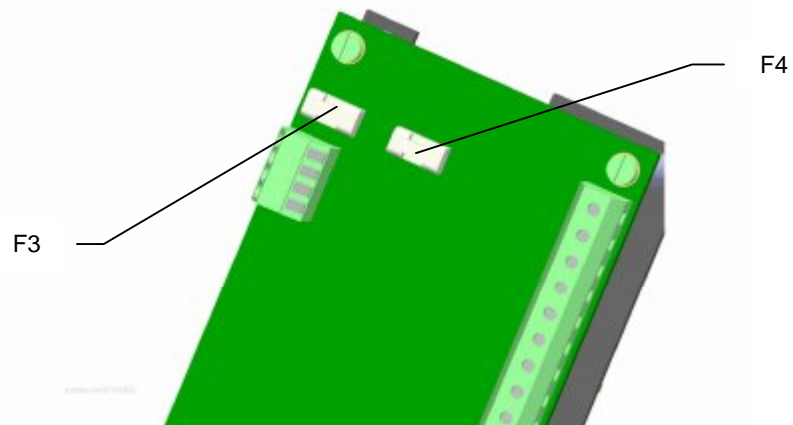

Fig.5

1.9 Packing, transport, storing and unpacking

Surfaces without surface treatment are treated by conservation preparation MOGUL LV 2-3 before packaging .

Conservation is not necessary if the following storage conditions are complied with:

- Storage temperature: -10 to +60 °C
- Relative air humidity max.80 %
- Electric actuators and their accessories must be stored in dry, well ventilated covered spaces, protected against impurities, dust, soil humidity (by placement to racks, or on palletes), chemicals and foreign interventions
- There shall be no corrosive gases present in the storage areas.

The EA MOR X.XPA are delivered in solid packages guaranteeing resistance in accordance with EN (IEC) 60 654-1 and EN (IEC) 60 654-3.

Package is a box. Products in boxes is possible to load on the pallets (pallet is returnable). On the outer side of the package is stated:

- manufacturer label,
- name and type of product,
- number of pieces,
- other data – notices and stickers.

The forwarder is obliged to secure packed products, loaded on transportation means, against self-motion; if open transportation means are used, to secure their protection against atmospheric precipitations and splashing water. Displacement and securing of products in transportation means must provide their stable position, exclude the possibility of their inter-collision and their collision with the vehicle walls.

Transportation can be executed by heatless and non hermetic spaces of transportation vehicles with influences within the range:

- temperature: -25° C up to +70° C (a strange version – 45 ° C up to + 45 ° C)
- humidity : 5 up to 100 %, with max. water content 0.029 kg/kg of dry air
- barometric pressure 86 up to 108 kPa.

Upon receiving of EA examine, if during transportation, resp. storing did not come to its damage. At the same time verify, if the data on the plates corresponds to accompanying documentation and purchase-sale contract / order. Eventual discrepancies, faults and damages should be reported without any delay to supplier.



Electric actuators and their accessories must be stored in dry, well ventilated covered spaces, protected against impurities, dust, soil humidity (by placement to racks, or on palletes), chemicals and foreign interventions, at ambient temperature from -10°C up to +60°C and at relative air humidity max. 80 %.

It is not acceptable to store EA outdoors, or in areas not protected against direct climate influence!

Eventual damages to surface finish remove without delay – thus preventing damage by corrosion.

If storing takes longer than 1 year, it is necessary to inspect lubrication fillings before putting EA into operation and in case of need perform maintenance.

Assembled EA, but not put into operation is necessary to protect by the equivalent method as during storage (for example suitable protective cover).

After assembly to the armature in free and wet areas, or in areas with temperature changes, connect without delay heating resistor – thus preventing damages caused by corrosion from liquefied water in the control area.

Excessive preserving grease remove just before putting EA into operation.

1.10 Assessment of the product and packaging and removal of contamination

The product and its package are made of recycling materials. Do not throw the single parts of the package and of the product after their life but sort them according to instructions in corresponding executives or regulations of environment protection, and allow their recycling.

The product and its packing are not a source of any environment pollution or contamination and do not contain any dangerous waste.

2. Installation and dismantling of actuator



Abide by safety measures!

Notes:

Repeatedly verify whether placing of EA correspondents to part "Operating conditions". If actual conditions differ from recommended, it is necessary to consult it with manufacturer.

Before starting of mounting the EA onto the valve:

- Check again whether the EA was not damaged during storing.
- Check whether the adjusted operating speed angle and connecting dimensions of the actuator (see the name plate) are in compliance with the valve parameters.
- In case of inconsonance, perform adjusting according to the part 3 Adjusting of actuator.

2.1 Installation

The actuator is set up by the manufacturer to the parameters according to name plate, with connecting dimensions according to relevant dimensional drawing and is set to mid - position.

2.1.1 Mechanical connection to the armature

Put on the hand wheel before assembly. In case that required shape of mechanical connection is designed by adapter (with flange F16, F14 or F10) at first is necessary to fix this adapter to connecting flange of EA by the screws.

Mechanical connection – shape of connecting element B, C, D, E (eventually B3) and gear clutch :

Bearing surfaces of EA connecting flange must be carefully de-greased.

Slightly grease the shaft of armature/gearbox by acid-free grease;

Shift EA to its end position „CLOSED“; shift armature into identical end position after electric connection.

Put EA on armature, so as output shaft reliably fits into clutch of armature after electric connection.

Warning!

Do not use force when you put EA on armature, otherwise the gear can be damaged!

- Should there is the necessity to synchronize the openings in the EA flange and armature, turn the EA by hand wheel;
- Verify, whether connecting flange fits tightly to the armature / gearbox.
- Attach the flange by four bolts (with mechanical hardness min. 8G), which steadily tighten crosswise.
- At the end of mechanical connection perform **the check of proper connection with the armature**, by turning hand wheel in the „open“ direction.

Mechanical connection – rising spindle (for shape A resp. C):

- If the rising spindle of armature is in end position „open“ longer than dimension of mounting flange up to the control box cover, disassembly cover of output shaft (Fig.1) on control box and replace it by covering pipe (not part of delivery) after assembly of electric actuator on armature.
- Seating surfaces of EA connecting flange and armature carefully de-grease.
- Slightly grease the output shaft of armature.
- Shift EA to end position „CLOSED“; shift armature into identical end position after electric connection.
- Slide electric actuator by output shaft / nut on the spindle / nut of armature and turn by hand wheel counterclockwise until connecting flange of electric actuator fits to connecting flange of armature. Further procedure is identical to previous part of mechanical connection for shapes B, C, D.
- At the end of mechanical connection perform the check of proper connection of EA with the armature by tur-ning the hand control wheel wheel in the „open“ direction.

Note:

It is also possible to fix the EA on the wall construction using the three feeders located at the box external wall, opposite to the hand wheel.

2.1.2 Electric connection to the network, respectively control system

Follow up with connecting the EA with mains or master system.



1. Follow instructions in the part "Requirements for professional qualification"!
 2. *While laying electrical line abide by the instructions for heavy current installations. Power supply cables must be of the type approved. Minimum thermal resistance of power supply cables and wires must be +80°C . (The cable Ölflex 440P 1.5 7G with thermal Insulation resistance -50° C to +90 ° C is assembled in the factory.).*

3. Cables to terminal boards or connectors lead through screw cable glands.
4. *Before initiation EA into operation internal and external protection terminals are needed to be connected.*
5. *Feeding cables are to be fixed to the solid construction at most 150 mm from the cable glands.*
6. *To prevent moisture from entering the actuator around the connecting cables, the cables must be sealed with silicone material at the point of penetration through device shell.*

Connecting with the master system:

EA can be controlled by:

- analogue signals through the built-in position controller
- binary inputs 24 V DC
- with Modbus/Profibus communication protocol

EA is connected according to wiring diagram under the cover of EA.

Notes:

1. *For connecting of input control signals and output signals it is necessary to use shielded wires with Galvanised Steel Wire Braid Ξ GSWB, e.g. type cable „Bruflex® HSLCH“, 4x0,5 (fy Bruns Kabel).*
1. *The EA are delivered with cable glands, which in case of tight putting on the leads assure protection enclosure up to IP 68. For required protection enclosure it is needed to use rings according to the actual cable diameter.*
2. *While fixing the cable it is needed to count with allowed bend radius to avoid damaging or deformation of the sealing element of the cable gland. The leads are to be fixed with the solid construction at most 150 mm from the cable glands.*
3. *The face areas of the control part cover have to be before re-mounting clean, coated with grease without any acid (e.g. vaseline) and sealing not damaged to avoid joint corrosion.*
4. *Reversation of the EA is sure, if the period between switching-off and switching-on of power supply for the reversed movement of the output part is minimally 50 ms.*



In version **MOR X.XPA** it is necessary to do **calibration** in operation according by enclosure assure the optimal function.



Abide by instructions of valve producers, whether switching-off in end positions is to be realised with position or torque switches.

2.2 Dismantling



Attention!

Before disassembly is necessary to disconnect electric supply of electric actuator!

Connection and disconnection of connectors must not be performed under the voltage!

Secure by prescribed way protection against connection of EA to the network and thus potential electrical accident!

- Disconnect the EA from mains.
- Disconnect the leads from the EA terminal boards and loosen the cables from cable glands.
- Loosen the fixing screws of the EA flange and disconnect the EA from the valve/gearing.
- While sending the EA to be repaired put it into a package solid enough to avoid damages of the EA during transportation.

3. Adjustment of actuator



**Attention! See chapter 1.2.2 Requirements for professional qualification ...
Disconnect the electrical electric actuator from electrical power network!
Observe safety regulations! Follow the prescribed procedure to assure that the EA is not connected to mains when live not to cause any injury by electrical current!**

EA are delivered adjusted onto parameters according to name plate from Manufacturer.

The adjustment can be performed at a mechanically and electrically connected EA. This chapter describes how to set up the EA to parameter values within a range applicable for the software. Laying of adjusters of the control board is shown on **Fig.6 and Fig.6a**.

Adjustment is possible:

- by operating the control unit buttons (**see Fig. 6 and Fig.6a**)
- by operating the local control panel buttons (**see Fig. 7**) – only for the EA s equipped with local control;
- through the programme once the EA is connected to the PC using the communication cable.

For the specific adjustment procedure or individual parameters reset see individual appendixes **74 1053 02 & 74 1076 02**.

For facilitating the simple setting of required operation parameters, the control unit is equipped with :

- four setting buttons: **MENU, P, O, C**
- six signal lamps according (LED diode) to **Fig. 6 and Fig.6a**.

Status indication by means of LED diodes:

- **LED ERROR** (red) – blinks red in case of failure eventually lights in the parameter setting mode
- **LED OPEN / MENU** (green) – in the ON/OFF mode it lights with a control action for the **opening** direction eventually blinks with accessing the MENU mode
- **LED CLOSE / PAR** (red) – in the ON/OFF mode it lights with a control action for the **closing** direction eventually blinks besides the chosen parameter in the menu and lights up at writing the parameter into the memory
- **LED I1 / SEL** (yellow) – permanent lights with active input I1, or blinks in the mode of parameters set up.
- **LED I2** (yellow) – permanent lights with active input I2
- **LED POWER** (green) – it light on at leading the power supply.

For version with Modbus communication

- LED DEX1 (yellow) – permanent lights during Modbus single Channel communication
- LED DEX2 (yellow) – permanent lights during Modbus duo Channel communication.

more LED for Profibus version

LED DEX1/ERR (yellow/red) - Profibus chanel 1

- yellow - permanent lighting by active communication, chanel in DATA Exchange mode
- red - permanent lighting by faulty communication, chanel is not in DATA Exchange mode
- red - blinking by Fatal Error (necessary to restart an actuator - switch-off and afterthen switch on)

LED DEX2/ERR (yellow/red) - Profibus chanel 2

- yellow - permanent lighting by active communication, chanel in DATA Exchange mode
- red - permanent lighting by faulty communication, chanel is not in DATA Exchange mode
- red - blinking by Fatal Error (necessary to restart an actuator - switch-off and afterthen switch on)

Electronics - programme selections option according to version

- **relay R1; R2; RE1 - RE5**: disabled; open position; close position; torque-open; torque – close; torque open or torque close; torque open or position open; torque close or position close; open; close; movement; movement flasher; to position; from the position; warning; remote control; local control; control shut off, relé READY.
- **relay READY**: errors, errors or warnings, errors or no remote, errors or warnings or no remote.
- **output signal** (from EPV passive): 4 to 20 mA; 20 to 4 mA.
- **control programme options** (regulating): 2P, 3P, 3P/2P I2
- **input control signal** (N): 0/4/12 to 20 mA, 4 to 12 mA, resp. 0/2 to 10 V.
- **input I1**: DISABLED; ESD; DBL (local releasing - not valid for EA's without local control), STOP
- **input I2**: DISABLED; ESD; DBL (local releasing - not valid for this type of the EA), 2P resp. E2P (for control programme option 3P/2P I2, or in case of active communication through Modbus/Profibus protocol, allows control using the binary 24V DC inputs with I2 input activated).
- **FAILURE REACTION**: OPEN, CLOSE, STOP, SAFE POSITION

The identical functions cannot be set on **I1** & **I2** inputs in addition to the OFF state (e.g., if the ESD function is set on **I1** input, it is not possible to select the ESD function on I2 input at the same time.

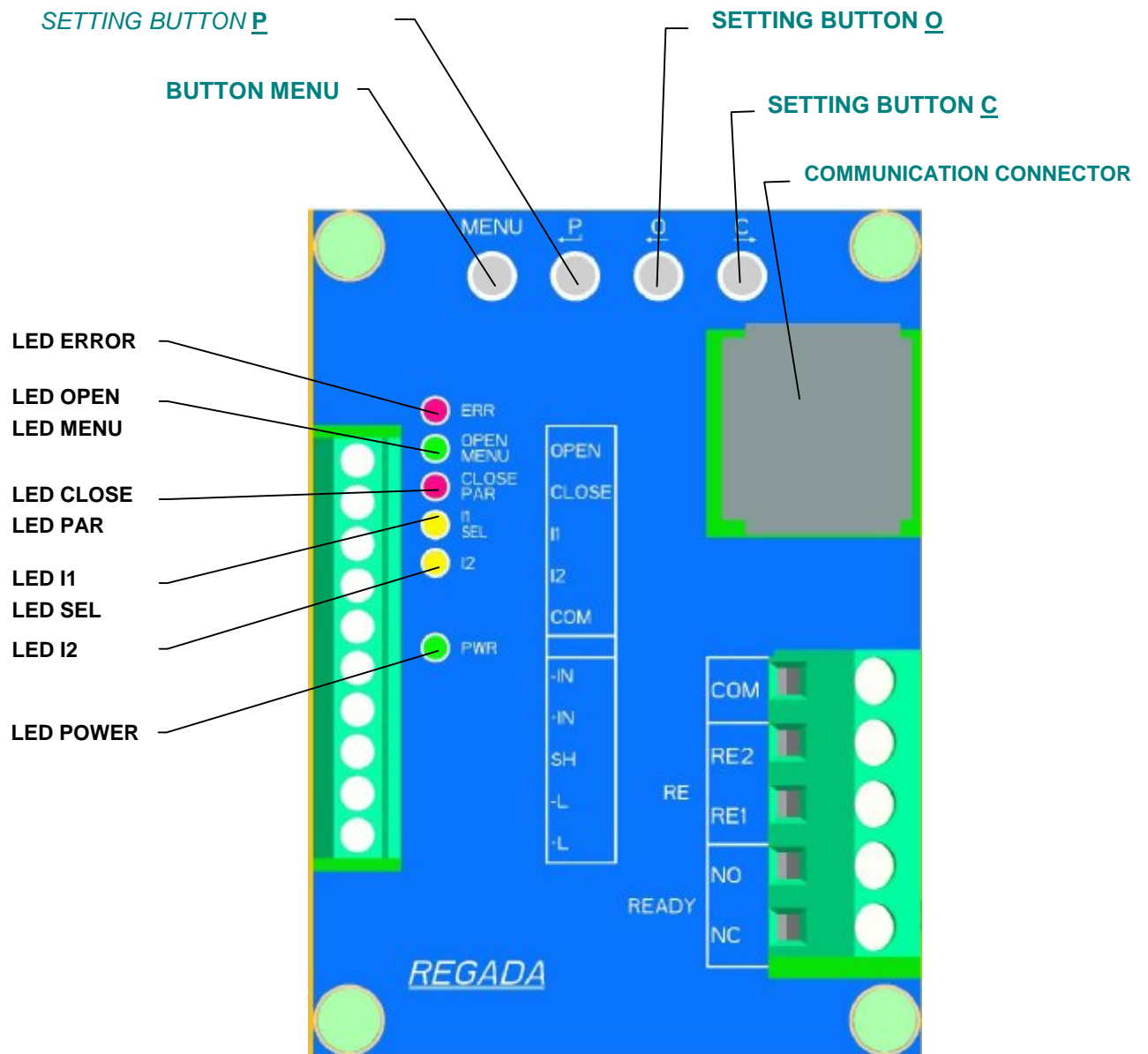

Fig. 6

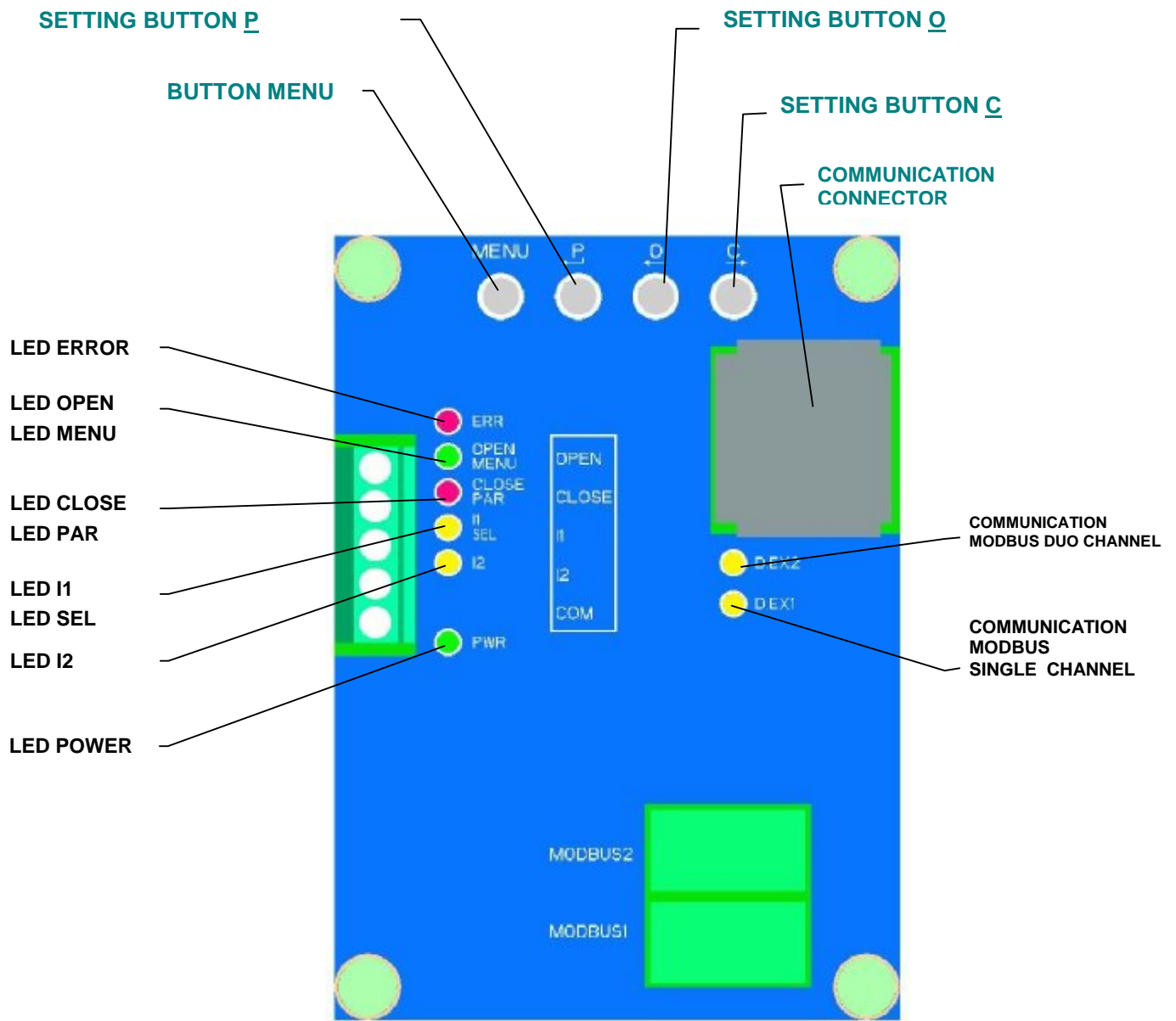

Fig.6a

3.1 EA control set-up options (regulating)

3.1.1 Control setting possibilities for EA's with DMS3 electronic control

2P CONTROL

Setting-up: **2P** control + other functions, in addition to **STOP** on I1 outlet:

The EA moves either to the OPEN or CLOSE direction with **24V DC** voltage supplied to terminals **OPEN** or **CLOSE**. The EA stops if power supply is cut-off or the end position is reached.

3P CONTROL (REGULATING)

Setting-up: **3P** control + other functions, in addition to STOP on I1 and other ones in addition to 2P on I2 input:

The EA moves either to the OPEN or CLOSE direction with **0/4/12 to 20 mA, 4 to 12 mA (0/2-10V) input control signal** supplied on terminals **+IN, -IN**. The EA stops once the required position is reached (corresponding with the input control signal supplied) or the set end position is reached.

Note: *The EA fails to stop in case that the STOP function is selected on I1 input with 3P control mode and 24V DC voltage supplied on I1 terminal.*

3P/2P switched over to I2

Setting-up: **3P/2P** control switched over to **I2** (**2P** function is automatically selected for **I2** input function in selecting this control option) + other functions in addition to STOP on I1.

The EA moves either to the OPEN or CLOSE direction with **0/4/12 to 20 mA, 4 to 12 mA (0/2-10V) input control signal** supplied on terminals **+IN, -IN**. The EA stops once the required position is reached (corresponding with the input control signal supplied) or the set end position is reached.

The EA stops to respond to **0/4/12 to 20 mA, 4 to 12 mA (0/2 to 10 V) input control signal** and rests in case of **I2 active input** (with 24V DC constantly ON or OFF – as per I2 function set-up to ACTIVE – or supplied on I2 connector). The EA is allowed to move either to the **OPEN** or **CLOSE** direction with **24V DC** voltage supplied to terminals **OPEN** or **CLOSE**. The EA stops if power supply is cut-off or the end position is reached. The EA stops to respond to the input control signal and fixes its position once the supply voltage on I2 is OFF.

3P/2P switched over to I2 (PULSE 2P)

Setting-up: **3P/2P** control switched over to **I2** (**2P** function is automatically selected for **I2** input function in selecting this control option) + other functions in addition to **STOP** on **I1**:

The EA moves either to the OPEN or CLOSE direction with **input control signal 0/4 – 20 mA (0/4/12 to 20 mA, 4 to 12 mA (0/2-10V))** supplied on connectors **+IN, -IN**. The EA stops once the required position is reached (corresponding with the input control signal supplied) or the set end position is reached.

The EA stops to respond to **0/4/12 to 20 mA, 4 to 12 mA (0/2-10V) input control signal** and rests in case of **I2 active input** (with 24V DC constantly ON or OFF – as per I2 function set-up to ACTIVE – or supplied on I2 terminal). The EA is allowed to move either to the OPEN or CLOSE direction with **24 V DC** voltage pulse supplied connectors **OPEN** or **CLOSE**. The EA stops once the 24V DC voltage is supplied on **I1** terminal (STOP) or the set end position is reached.

The EA stops to respond to the input control signal and fixes its position once the supply voltage on I2 is OFF.

3.1.2 Control setting possibilities for EA's with DMS3 electronic control with Modbus/Profibus protocol

2P CONTROL (two position controller)

Setting: the two position controller is activated by setting the bit 3P=0 in the corresponding Modbus/Profibus register:

The EA moves in the direction of open or closed **when the bits are set as OPEN, resp. CLOSE in the corresponding Modbus/Profibus register.**

3P CONTROL (three position controller)

Setting: the three position controller is activated by setting the bit 3P=1 in the corresponding Modbus/Profibus register:

The EA moves in the direction of open or closed **in accordance with the requirements sent through the Modbus/Profibus interface.**

EMERGENCY CONTROL

Note: In cases where the EA is equipped with a local control, it is possible to activate the emergency control only if the local control block is set to remote control. The local control block has higher priority than the **ESD** or **E2P**.

- **ESD (Emergency Shutdown)** – is activated when the function parameter is set as **I1=ESD** and the I1 input is activated or when the function parameter is set as **I2=ESD** and the I2 input is activated. The EA takes up the position which corresponds to the settings of the **response to error parameter after input activation**. The **ESD emergency control has higher priority than the E2P control**.
- **E2P (Emergency 2P)** – is activated when the function parameter is set as **I2=E2P** and the I2 input is activated. The **E2P emergency control has lower priority than the ESD control**. Emergency 2P operates in two modes and uses the following inputs:
 - **Permanent signal** – the EA opens or closes only when a signal is present on the **OPEN, CLOSE inputs**.
 - **Impulse mode** – the EA opens or closes after supplying an impulse to the **OPEN, CLOSE inputs**. The EA is stopped after supplying an impulse to the **I1 input**. This mode is similar to the settings of the function **I1=STOP**.

3.2 Procedure for setting individual parameters and the register of errors and warnings

- is given in the separate attachment 74 1053 02 resp. 74 1076 02 of these operating instructions.

The factory default setting of individual programmes shown in Table 2 & 3, as long as otherwise specified by the customer:

Table 2

Factory default settings of individual parameters in version without local control; possibility to set-up by operating the control unite buttons.

For the individual parameters set-up see appendix 74 1053 02

MENU			NAME	FACTORY SETTING-UP	
DMS3	MODBUS	PROFIBUS			
1			TORQUE	100% of value shown on nameplate for OPEN & CLOSE direction.	
2			END LIMIT	- C = Position + O = Position - end position switching closed and open from position if valve type is not specified - C = Torque + O = Position - closed in end by thrust position and end position switching open from position for single-seat valves - C = Torque + O = Torque – switching in both end positions by thrust for double-seat valves	
3			TORQUE BLOCKING	- 2 sec. blocking time - 5% blocking position for OPEN & CLOSE direction	
4			RELAY READY	- errors (READY COM-NO relay contacts closed in error free conditions)	
5			RELAY R1..RE5	- position O for relay R1, RE1 - position C for relay R2, RE2 - from position 95% for relay RE3 - To position 5% for relay RE4 -disabled for RE5 relay	
6	-	-	CPT (output signal)	4 to 20 mA	
7	-	--	REGULATION – (according to specification)	2P	3P
			ANALOG INPUT	-	4 to 20 mA (2 to 10 V)
-	5	-	ADDRESS	2	
-	-	6	ADDRESS 1	2	
			ADDRESS 2	3	
-			BAUDRATE PARITY REDUNDANCY	115200 bit/s EVEN OFF (for single Channel version) COMPONENT (for duo Channel version)	
-	-	7	REDUNDANCY	OFF (for single Channel version) Single (for duo Channel version.)	
8			DEAD ZONE	-	3 %
9			FAILURE REACTION	STOP	

Other parameters set-up not possible to change using the PC software

TITLE	FACTORY SETTING-UP
THERMOSTAT TEMPERATURE	25 °(space heater OFF temperature)
INTERNAL DEAD ZONE	2 % (only for 3P)
Safe position	0 %
FUNCTION I1	ESD
ACTIVE I1	high level
FUNCTION I2	DISABLED

ACTIVE I2	high level
THERMAL FUSE FAILURE	Overheating is activated
THERMAL FUSE RESET	Automatically
CYCLE MODE	DISABLED
CYCLE RUNNING TIME	10 s
CYCLE PAUSE	50 s
CYCLE POSITION O1	0 %
CYCLE POSITION O2	100 %
CYCLE POSITION C1	0 %
CYCLE POSITION C2	100 %
O AND C TOLERANCE	1 %
CREATE BACKUP	START
RESTORE FROM BACKUP	START
RESTORE FACTORY SETUP	START
ACTIVE ERRORS	CLEAR
DIRECTION OF ROTATION	clockwise
REDUNDANCY	OFF
CONNECT TIME (Modbus)	3s

Table 3

Factory default settings of individual parameters in version with local control; possibility to set-up by operating the local control buttons. For the individual parameters set-up see appendix 74 1076 02.

MENU			NAME	FACTORY SETTING-UP	
DMS3	MODBUS	Profibus			
1			JAZ/LANGUAGE	English (select language on LCD display)	
2			POSITION O	work angle range set as per EA specification	
3			POSITION C		
4			REG. CALIBR.	START	
5			END LIMIT	C = Position, O = Position - end position switching	
6			TORQUE O	100% of value shown on nameplate	
7			TORQUE C	100% of value shown on nameplate	
8			BLOCK. TIME	2 s	
9			BLOCK. POS. O	5 %	
10			BLOCK. POS. C	5 %	
11	-	-	CPT (output signal)	4 to 20 mA	
12	-	-	REGULATION-(according to	2P	3P
13	-	-	ANALOG. INPUT	-	4 to 20 mA (2 to 10 V)
14	16	14	DEAD ZONE	-	3 %
15	17	15	INT. DEAD Z.	-	2 %
16	18	16	FAIL. REACT.	STOP	
17	19	17	SAFE POSIT.	0 %	
18	20	18	FUNCTION I1	ESD	
19	21	19	ACTIVE I1	high level	
20	22	20	FUNCTION I2	DISABLED	
21	23	21	ACTIVE I2	high level	
22	24	22	THERMO. FAIL. (THERMAL FUSE	Overheating is activated	
23	25	23	THERMO. RESET (THERMAL FUSE	Automatically	
24	26	24	RELAY READY	errors	
25	27	25	RELAY 1	Position O (POSITION OPEN)	
26	28	26	RELAY 1 POS.	0 %	
27	29	27	RELAY 2	Position C (POSITION CLOSE)	
28	30	28	RELAY 2 POS.	0 %	
29	31	29	RELAY 3	FROM POSITION	

30	32	30	RELAY 3 POS.	95 %
		31	RELAY 4	TO POSITION
		32	RELAY 4 POS.	5 %
33	35	33	RELAY 5	DISABLED (OFF)
34	36	34	RELAY 5 POS.	0 %
35	37	35	CYCLE MODE	DISABLED
36	38	36	CYCLE RUN. T.	10 s
37	39	37	CYCLE PAUSE	50 s
38	40	38	OC TOLERANCE	1 %
39	41	39	INFORMATION	TORQUE
40	42	40	RESTORE BACK.	START
41	43	41	CREATE BACK.	START
42	44	42	RESTORE FACT.	START
43	45	43	ACTIVE ERR:	CLEAR
-	-	44		
-	11	-	ADDRESS	2
-	12	-	BAUDRATE	115200bit/s
-	13	-	PARITY	EVEN
-	14	-	REDUNDANCY	OFF (for single Channel version) COMPONENT (for duo Channel version)
-	15	-	CONNECT TIME	3s
-	-	11	ADDRESS 1	2
-	-	12	ADDRESS 2	3
-	-	13	REDUNDANCY	OFF

Other parameters set-up is possible to change only by using the PC software

NAME	FACTORY SETTING-UP
DIRECTION OF ROTATION	clockwise
THERMOSTAT TEMPERATURE	25 °(space heater OFF temperature)
CYCLE POSITION O1	0 %
CYCLE POSITION O2	100 %
CYCLE POSITION C1	0 %
CYCLE POSITION C2	100 %
LCD CONTRAST	0

Warning 1: When the input control signal is set to the value 0 , 20 mA (0 to 10 V), or 20 , 0 mA (10 to 0 V) and the input control signal fails, then the EA keeps the position as with a 0 mA (0 V) input signal (EA doesn't recognise between input signal fail and 0 mA (0 V) input signal)- not valid for EA EA's with DMS3 electronic control with Modbus/Profibus protocol.

Warning 2: Calibration process doesn't run if triggered in time when the EA is overloaded (EA is switched- off from overloading). In such case error is needed to be corrected i.e. the EA must be moved in a position in which EA is not switched – off from overloading, and to start the calibration again.

Warning 3: Calibration process must be performed at any change of the operating stroke value of more than 10%.

Warning 4: Operate adjusting button P on the control to activate the calibration process or start it from MENU 4 in the version with local control (use the buttons on local control) or from the programme once the EA is connected to the PC. All calibration start methods have been equal.

Rotation direction definition of the electric actuator's output element

Electric actuator is set by the producer in the following way: while looking at the output shaft of the actuator from the upper cover side, the output shaft moving in the direction "Close" is rotating clockwise. It means that the direction of rotation of the actuator is set as **clockwise**

In case the direction of rotation shall be changed the parameter „Direction of rotation of the actuator“ must be adjusted as **anticlockwise**. This parameter can be adjusted through the PC only by

use of the EHL Explorer SW. The PC must be connected to the actuator via communication cable and the window "Parameters" used for direction adjustment, in some cases by local control buttons.

3.3 Putting an EA into operation when the EA is set up and connected with the armature already in the manufacturer (starting the calibration)

If EA is delivered from manufacturing plant joined with valve, or with control device, **calibration** must be performed to ensure correct operation, under actual pipeline conditions.

The procedure is as follows:

- fit the given assembly into the specified technology complex
- connect the EA on the supply voltage electrically according to the wiring diagram and chapter 2.1.2 Electric connection....
- introduce the EA into an half-position (see Note 2 presented above)
- switch on the supply voltage
- start the EA calibration by pressing the **P** button on the control unit **for 2 seconds as minimum** until LED ERROR (red), LED MENU (green) and LED PAR (red) light up – see also the procedure in the separate attachment No.74 1053 02
- release the **P setting button**
- after releasing the **P** button the calibration procedure starts – inertia measuring
- after the calibration procedure is finished, the EA is prepared for its operation and starts to response to control inputs
- if changes to some parameters would be necessary, proceed please according to the instructions given in the separate attachment No. **74 1053 02**.

3.4 Putting an EA into operation when the parameter setting done by the producer suit to your needs

When an EA is delivered from the producer without armature and the setting of stroke (stroke end positions) and other parameters done by the producer suit Your needs, please proceed as follows:

- connect the EA with the armature to be controlled (**according to chapter 2**) and fit this assembly into the specified technology complex
- connect the EA electrically according to the wiring diagram and chapter 2.1.2 Electric connection ...
- introduce the EA into an half- position (see Note 2 presented above)
- switch on the supply voltage
- start the EA calibration by pressing the **P** button on the control unit **for 2 seconds as minimum** until LED ERROR (red), LED MENU (green) and LED PAR (red) light up – see also the procedure in the separate attachment No. 74 1053 02
- release the **P setting button**
- after releasing the **P** button the calibration procedure starts
- after the calibration procedure is finished, the EA is prepared for its operation and starts to response to control inputs
- if changes to some parameters would be necessary, proceed please according to the instructions given in the separate attachment No. 74 1053 02.

3.5 Putting an EA into operation when it is necessary to do a change to the stroke (setting new end positions), and the other parameter setting done by the producer suits to your needs

When an EA is delivered from the producer without armature, and the setting of other parameters done by the producer suit to your needs, and it is necessary to do a change to the EA stroke, proceed as follows:

- connect the EA with the armature to be controlled (according to chapter 2) and fit this assembly into the specified technology complex,
- connect the EA electrically according to the wiring diagram and chapter Electrical connection... ,turn on the power supply, without connection of the control signals fed into EA (The EA will report an error i.e. alarm No. 2 or No. 27 (missing input control signal - or Modbus activity),

- set the EA (using manual control*) to end position closed and push button C for at least 2s, until LED ERROR (red), LED MENU (green) and LED PAR (red) come on – the closed end position is thus recorded in memory – see description in separate annex No. 74 1053 02,
- release the C setting button,
- set the EA (using manual control*) to end position opened and push button O for at least 2s, until LED ERROR (red), LED MENU (green) and LED PAR (red) come on – the opened end position is thus recorded in memory – see description in separate annex No. 74 1053 02,
- release the O setting button,
- introduce the EA into an intermediate position (see Note 2 presented above),
- by pressing the P pushbutton on the control unit for at least 2s activate the EA calibration until LED ERROR (red), LED MENU (green) and LED PAR (red) come on – see also description of the procedure in separate annex No. 74 1053 02,
- release the adjustment pushbutton P - upon release of the P pushbutton, the calibration process is started,
- turn on the control signals, EA is ready for operation and responds to control inputs,
- if any of the parameters need to be changed, proceed according to the instructions in separate annex No. 74 1053 02.

** This applies to the standard setting of menu 9 (in the menu on the control unit) FAILURE REACTION: STOP! If the input control signal is set to one of the ranges starting from 0 mA, it is necessary to change the range to a different one. If this is not the case and a control signal is not supplied, the servodrive output component will take up the position corresponding to 0 mA. After recording the new limit positions change the value of the input control signal and response to error to the required parameters.*

Note: in cases where the sequence is implemented using a PC in the EHL Explorer programme or using local control, neither the change of response to error nor disconnection of the control signals is required.

3.6 Setting other parameters

If changes to some parameters would be necessary, proceed please according to the instructions given in the separate attachment No 74 1053 02.

3.7 Error messages from the control unit

The EA electronics makes possible to identify some failures of EA. The failure is signalled by flickering LED ERROR (red) on the control unit (**Fig.6**). An error has also been indicated on the LED display. An error is indicated on the LCD display in the local control EA version.

The list of errors and warnings and the way for identifying a given error as well are presented in the separate attachment No. 74 1053 02. For identifying the reason of the error, the EA can be connected to a PC and the program helps you find the type of the error.

The list of errors and warnings compiled by the producer is presented in table 4 (chapter 4.3).

The list of errors and warnings and the way for identifying a given error as well are presented in the separate attachment No 74 1053 02.

A field serviceman is only entitled to change the errors and warnings set using the programme once the EA is connected to the PC.

4. Service, maintenance and troubleshooting

4.1 Service



1. In general it is provided that service of the EA is performed by a qualified worker in accordance with requirement given in Chapter 1!

2. After putting the EA into operation it is needed to verify whether during manipulation any scratch on surface occurred, it is to be removed to prevent actuator against corrosion!

- Electric actuator requires only inconsiderable operation. The assumption for reliable operation is proper putting into operation.
- The operation of these EA comes out of operating conditions and usually consists of information processing for consequential securing of required function.
- EA can be controlled either remotely by electricians, or manually on their assembly position. Manual control is executed via hand wheel.
- The operators must take care for performing of prescribed maintenance and for protection of EA during operation against harmful ambient effects and atmospheric exposure, which exceeds the scope of acceptable effects described in part „Working conditions“.
- Operation beyond the switching – off torque limits is not allowed.
- It is necessary to prevent excessive heating of the surface of EA, exceeding of name plate values and excessive vibration of EA.

Manual control:

If needed (during adjusting, function checking, failure etc.) the stuff can change setting of the controlled body using the handwheel. While rotating the handwheel clockwise the output part moves in the direction "closed".

Before manual control must be realized locking screw. Fasten locking screw after finishing of manual control.

Electric local control: - additional equipment (Fig.7)

If necessary in the case of accession, function check and so on, it is possible to preset EA or change some parameters by local electric control with secured power feeding.

It is possible to control after removing of the padlock (1). Control mode selection is changed by sequential pressing of the button (2) **REMOTE-OFF-LOCAL** to **“Remote” “Shut off”, “Local”, “Shut off”**, which is displayed on 2 rows LCD (6). Signalling motion and failure of the EA is also indicated by LEDs diode (7).

Mode **“Shut off”** – it is possible to change some parameters in this mode in particular menus.

Mode **“Local”** – it is possible to control EA by the local buttons in this mode - (3) **OPEN**, (5) **STOP**, (4) **CLOSE**.

Mode **“REMOTE”** – it is possible to control EA by the commands from superior remote system

Proceeding in setup of particular parameters in the mode **“SHUT OFF”** is described in the independent amendment No. 74 1076 02, which is delivered together with EA equipped by local electric control.

When you finish the work in the **“REMOTE”** mode put the padlock on the button (2) again. This measure would be received because of potential unauthorized person’s intervention.

Note: Modes of Local or Remote control is conditioned by program choices of inputs I1 and I2. In the case that inputs I1 or I2 are programmed for “Local releasing”, it is only possible to control the EA by local control with active input I1 or I2.

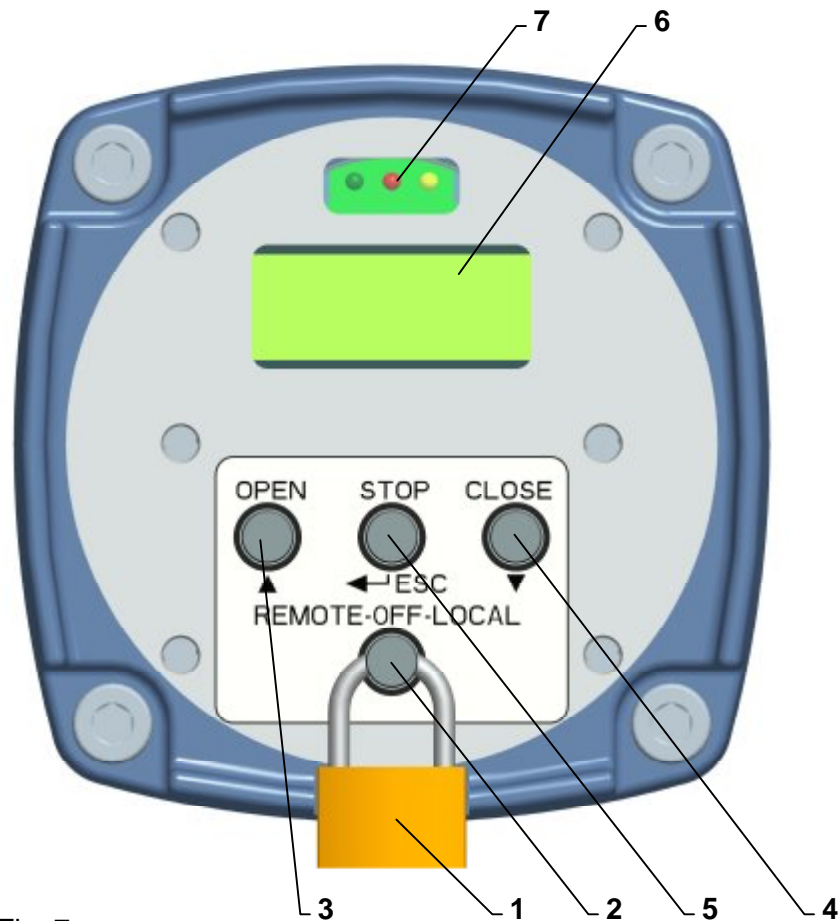

Fig. 7

4.2 Maintenance – scope and regularity

All screws and nuts affecting tightness and protection (IP) must be tightened during the inspection and maintenance. Similarly, once a year should be checked and if necessary tightened mounting screws of the terminal wires and assuring of the slip-on joints with wires.

The interval between two preventive inspections is four years.

In case of damage or after 6 years of the actuator's operation the replacement of cover seals and oil filling seals must be done.

The grease in the supplied actuators is designed for the lifetime of the product.

It is not necessary to change the grease during the operation of the actuator.

In case there is no leakage in the transmission box caused by damaged seal the oil filling is permanent. The change of oil filling shall be done after 6 years of the actuator's operation.

The oil level check must be carried out once in a 3 months interval. The oil level must reach the filling hole. Oil capacity is 1,6 l (1,5 kg) –MOR 3PA - MOR 4PA or 6 l – MOR 5PA .

Lubrication:

- the gearbox: in versions with temperatures -25°C till $+60^{\circ}\text{C}$ - Madit PP-80 (Slovnaft)
in versions with temperatures -60°C till $+60^{\circ}\text{C}$ - Avia SYNTOGEAR PE 68
- gears of transmission unit and drive mechanism on the control board:
 - in versions with temperatures -25°C till $+60^{\circ}\text{C}$ - grease μ HF 401/0, resp. GLEITMO585
 - in versions with temperatures -50°C till $+40^{\circ}\text{C}$ - ISOFLEX TOPAS AK 50
 - in versions for climate with temperatures -60°C till $+60^{\circ}\text{C}$ grease DISCOR R-EP 000..

***Lubrication of the valve stem is independent on maintenance of the EA!***

After every potential flooding of the product check, whether there is no water inside. After eventual water penetration, dry the product before repeated putting into operation and replace damaged sealings, resp. other parts of EA. identically check also tightness of cable bushings and replace them, if they are damaged.

Every six months it is recommended to perform one check move in frame of adjusted operation stroke to verify reliability of functioning with setting back to the original position.

If the audit rules do not determine else the inspection of EA is performed ones a year and tightening of all connecting and grounded screws have to be checked to avoid overheating.

After 6 months from putting of EA into operation and once a year it is recommended to check tightening of fixing screws between the EA and the valve. (Tighten the screws with the cross system.)

While connecting and disconnecting of the EA check the tightness of cable glands – those with damaged sealings should be replaced by new ones of the approved type!



Keep the EA clean and take care about removing impurities and dust. The cleaning has to be performed regularly according to the operation possibilities and requirements.

**4.3 Troubleshooting**

- At failure of power supply the EA stops in the position where it was before the failure. If needed the EA can be set only with the manual control (the hand wheel). After restoration of power the EA is prepared for operation.
- In case of failure of any element of the EA it can be changed by a new one. Entrust the change to a service center.
- In case of an EA failure, which *cannot* be eliminated directly in operation, follow instructions for under-guaranty and after-guaranty service.

**Note:**

If the EA requires dismantling follow the chapter "Dismantling".

The EA electronics makes possible to identify some failures of the electric actuator. The control unit blinking LED ERROR indicates the failure (**Fig. 6**) or the error is displayed on the LED (**see Fig. 3,3a**), or the LCD display (**see Fig. 7**). The list of errors and warnings and the way for identifying a given error as well are presented in the separate attachment No 74 1053 02.

The list of errors and warnings compiled by the producer is presented in **table 4**. A change to the list of errors and warnings in the EA is only possible within a service intervention, through the program installed in a PC.

Table 4-setting error flags and warning flags as at the delivery		
PARAMETER	ERROR	WARNING
ESD		X
Analog Input – not valid for Modbus/Profibus protocol		X
Modbus/Profibus activity – only for Modbus/Profibus protocol		X
Wrong command	X	
Torque		X
Torque check		X
Torque calibration	X	
Regulator calibration		X
Stroke (turns sum)	X	
Wrong position	X	
Spin	X	
Spin direction	X	
RAM	X	
ROM	X	
EEPROM		X
Bus	X	
I2C	X	
Reset		X
Voltage +5V		X
Parameters	X	
Set mode		X
Relay		X
Temperature <		X
Temperature >		X
Phase	X	
Power frequency	X	
Thermal fuse	X	
Manual control	X	
Position module	X	
Position module type	X	
Position sensor 1	X	
Position sensor 2	X	
Position sensor 3	X	
Position sensor 4	X	
Torque module	X	
Torque module type	X	
Torque sensor	X	
LED module	X	
LED module type	X	
LCD module	X	
LCD module type	X	
Power Supply/Relay module	X	
Power Supply/Relay module type	X	
E2P	X	
Profibus Channel 1- only for version with Profibus	X	
Profibus Channel 2- only for version with Profibus	X	
<p>Notes: X – the error or warning flag is activated. With the error flag, the EA takes the position defined for the FAILURE REACTION function eventually stops (depending on the kind of the error), and it will not operate until the error is removed. With the warning flag, the EA continues in operation. The user is advised on error or warning through the READY relay (according to the relay setting), eventually through the program after connecting the EA with a PC.</p>		

Note 1: In some cases having the error removed the electric actuator must be restarted by switching-off the voltage supply to the electric actuator for about 3 sec. The **producer's service centre** only is allowed for such replacement. For repairing eventually the electronics use the fuse – see chapter 1.9.2.



Taking the EA to pieces for repair purposes is allowed only by professionally qualified persons trained in the manufacturer or by a contracted service centre!

5. Accessories and spare parts

5.1 Accessories

The EA is delivered with the service handle and communication cable DB-9F/RJ45 (communication cable must be ordered separately).

5.2 Spare part list

Table 5 - Spare part			
Spare part	Order Nr.	Position	Figure
Electric motor ; 1LA(PP)7060-4AB13-Z/A11+K17;0,12kW, Δ/Y 230V/400V (MOR 3 PA)	63 592 xxx	M1	1
Electric motor; 1LA(PP)7070-6AA13-Z/A11+K17;0,18kW, Δ/Y 230V/400V (MOR 3 PA)	63 592 xxx	M1	1
Electric motor; 1LA(PP)7063-4AB13-Z/A11+K17;0,18kW, Δ/Y 230V/400V (MOR 3 PA)	63 592 xxx	M1	1
Electric motor; 1LA(PP)7070-4AB13-Z/A11+K17;0,25kW, Δ/Y 230V/400V (MOR 3 PA)	63 592 xxx	M1	1
Electric motor; 1LA(PP)7073-4AB13-Z/A11+K17;0,37kW, Δ/Y 230V/400V (MOR 3/3.4 PA)	63 592 xxx	M1	1
Electric motor; 1LA(PP)7083-6AA12-Z/A11+K17;0,55kW, Δ/Y 230V/400V (MOR 3/3.4 PA)	63 592 xxx	M1	1
Electric motor; 1LA(PP)9073-4LA13-Z/A11+K17;0,60kW, Δ/Y 230V/400V (MOR 3 PA)	63 592 xxx	M1	1
Electric motor; 1LA(PP)7083-4AA12-Z/A11+K17;0,75kW, Δ/Y 230V/400V (MOR 3/3.4 PA)	63 592 xxx	M1	1
Electric motor; 1LA(PP)9073-2LA13-Z/A11+K17;0,94kW, Δ/Y 230V/400V (MOR 3/3.5 PA)	63 592 xxx	M1	1
Electric motor; 1LA(PP)9083-4LA12-Z/A11+K17;1,25kW, Δ/Y 230V/400V (MOR 3 PA)	63 592 xxx	M1	1
Electric motor; 1LA(PP)7083-2AA11-Z/A11+K17;1,10kW, Δ/Y 230V/400V (MOR 3.4 PA)	63 592 xxx	M1	1
Electric motor; 1LA(PP)9080-2LA12-Z/ A11+K17; 1,45kW; Δ/Y 230V/400V AC;(MOR 3/3.5 PA)	63 592 XXX	M1	1
Electric motor; 1LA(PP)7090-2LA12-Z/ A11+K17; 1,50kW; Δ/Y 230V/400V AC; (MOR 3.4 PA)	63 592 XXX	M1	1
Electric motor; 1LA(PP)7113-4AA11-Z/ A11+K17; 4 kW; Δ/Y 230V/400V AC; (MOR 5PA)	63 592 XXX	M1	1
Electric motor; 1LA(PP)7107-4AA11-Z/ A11+K17; 3 kW; Δ/Y 230V/400V AC; (MOR 5PA)	63 592 XXX	M1	1
Electric motor; 1LA(PP)7113-6AA11-Z/ A11+K17; 2,2 kW; Δ/Y 230V/400V AC; (MOR 5PA)	63 592 XXX	M1	1
Electric motor; 1LA(PP)7106-6AA11-Z/ A11+K17; 1,5 kW; Δ/Y 230V/400V AC; (MOR 5PA)	63 592 XXX	M1	1
Electric motor; 1LA(PP)7107-8AB11-Z/ A11+K17; 1,1 kW; Δ/Y 230V/400V AC; (MOR 5PA)	63 592 XXX	M1	1
Electric motor; 1PP7080-4AA13-Z/A11+K17; 0,55 kW; Δ/Y 230V/400V (MOR 4PA)	63 592 XXX	M1	1
DMS3 Z3 source board of electronic 400V AC	64 051 073	9	3,3a
Control unit of the electronics REGA 4	64 051 075	10	3,3a
Control unit of the electronics DMS3 J3 (0/2 - 10 V)	64 051 061	10	3,3a
Control unit of the electronics DMS3 J2 (without input and output)	64 051 060	10	3,3a
DMS3 M1 - Control unit MODBUS Single Channel	64 051 051	10	3,3a
DMS3 M2 - Control unit MODBUS Duo Channel	64 051 052	10	3,3a
DMS3 P1 - Control unit PROFIBUS Single Channel	64 051 037	10	3,3a
DMS3 P2 - Control unit PROFIBUS Duo Channel	64 051 038	10	3,3a
Position sensing unit DMS3 SM	64 051 088	11	3,3a
Torque sensing unit DMS3 ST	64 051 080	12	3,3a
DMS3 L2 LED display	64 051 081	16	3,3a
DMS3 LCD display	64 051 082	6	7
DMS3 H3.4 local control sensor	64 051 084	-	7
Contacteur	63 581 432	13	3,3a
Thyristor unit (Solid state)	63 581 442	13	3,3a
Casing KU 40x30 (MOR 3PA-3.5PA)	63 249 037	75	2
Casing KU 14x12 (MOR 3PA-3.5PA)	63 243 150	76	2
Ringlet 10 x 6 (MOR 3PA-3.5PA)	62 732 022	66	2
Sealing ring 16 x 28 x 7 (MOR 3PA-3.5PA)	62735 044	70	2
Sealing ring 40 x 52 x 7 (MOR 3PA-3.5PA)	62 735 043	68	2
Ringlet 32 x 2 (MOR 3PA-3.5PA)	62 731 097	77, 34	2
Ringlet 110 x 3 (MOR 3PA-3.5PA)	62 732128	-	-
Ringlet 130 x 3 (MOR 3PA-3.5PA)	62 732 095	78	2
Sealing (MOR 3PA-3.5PA)	04 A05 199	-	-
Cable glands M16x1,5	224A76292	34	1
Cable glands M20x1,5	63 456 596	34	1
Cable glands M25x1,5	63 456 597	34	1

Warning: By supplying spare parts, the manufacturer is not responsible for damages caused by their disassembly and assembly. Installation, replacement of spare parts must be performed by authorized, qualified personnel.

6. Enclosures

6.1 Wiring diagrams with DMS3 electronic control

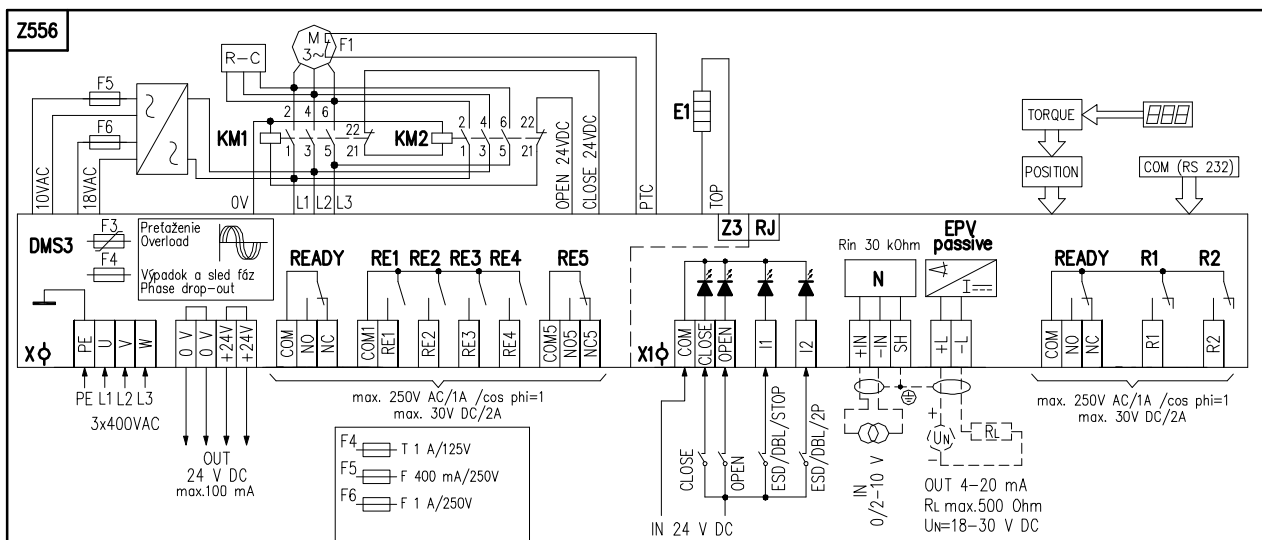
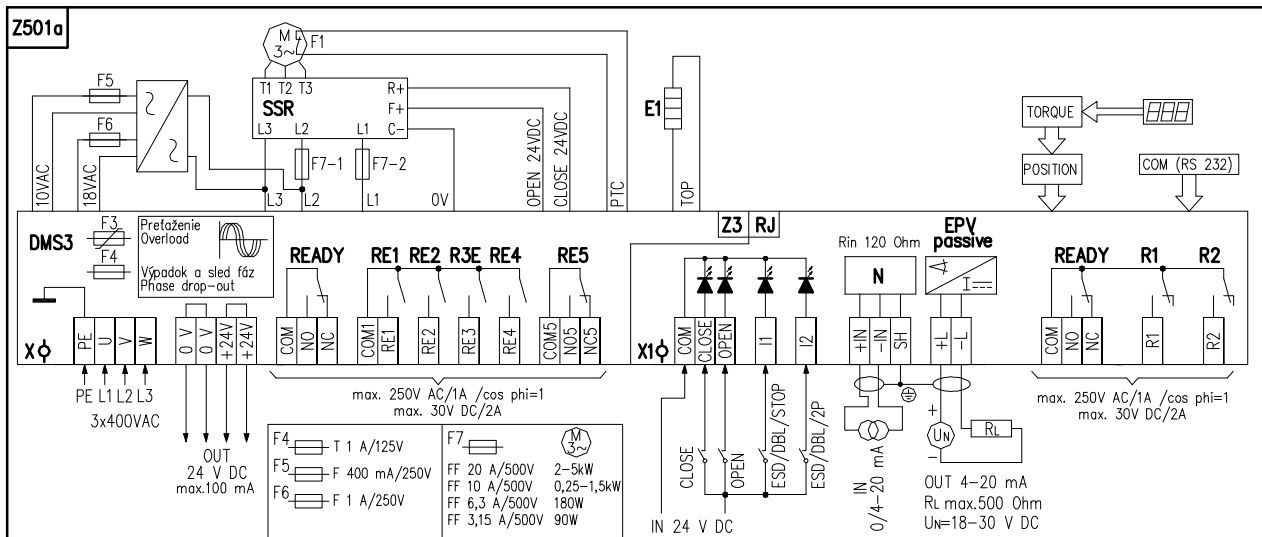
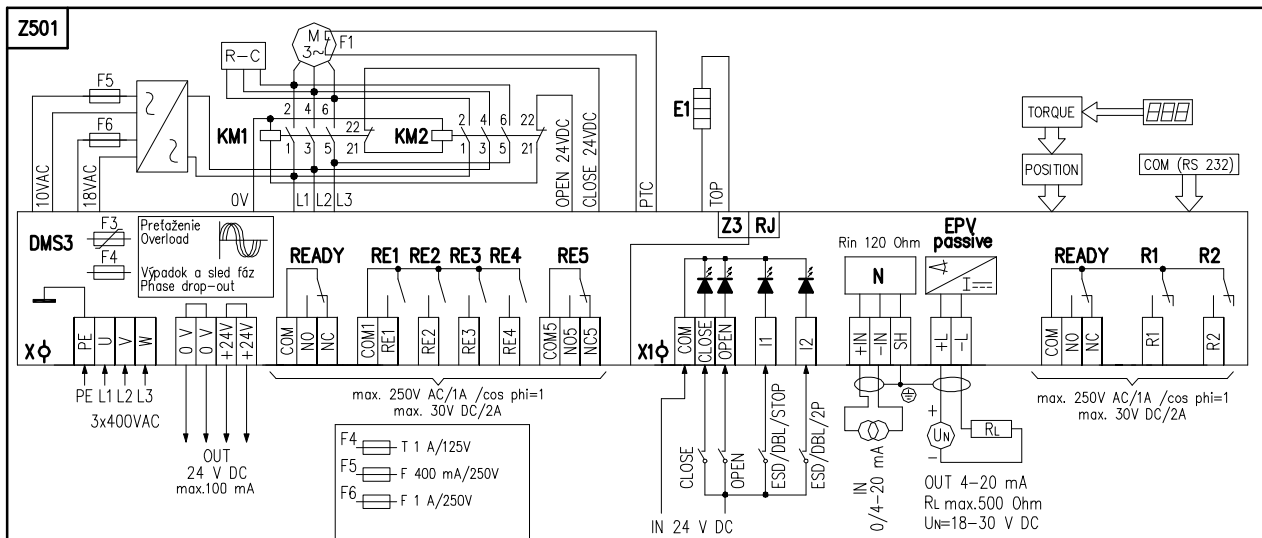

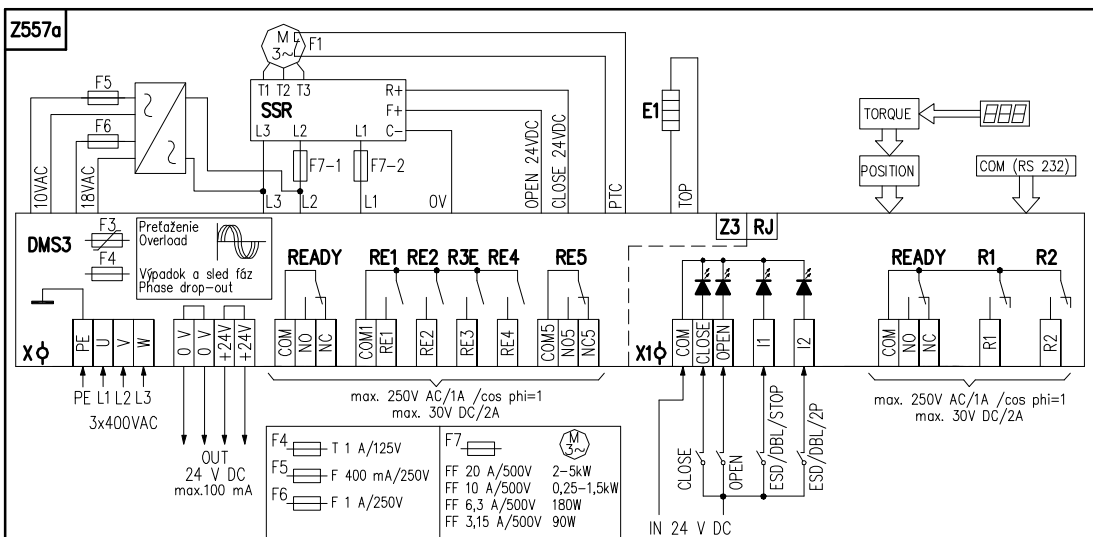
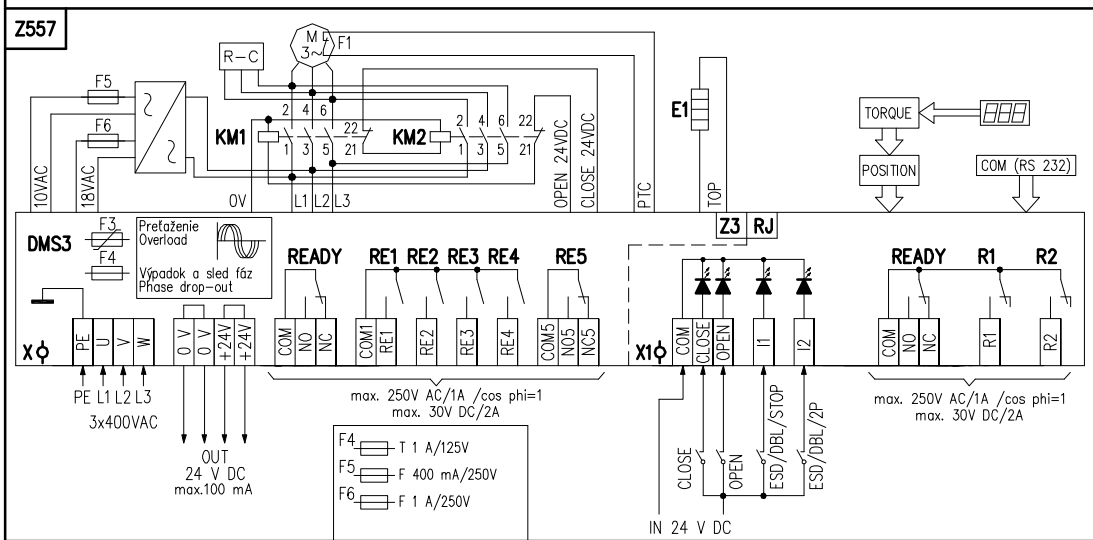
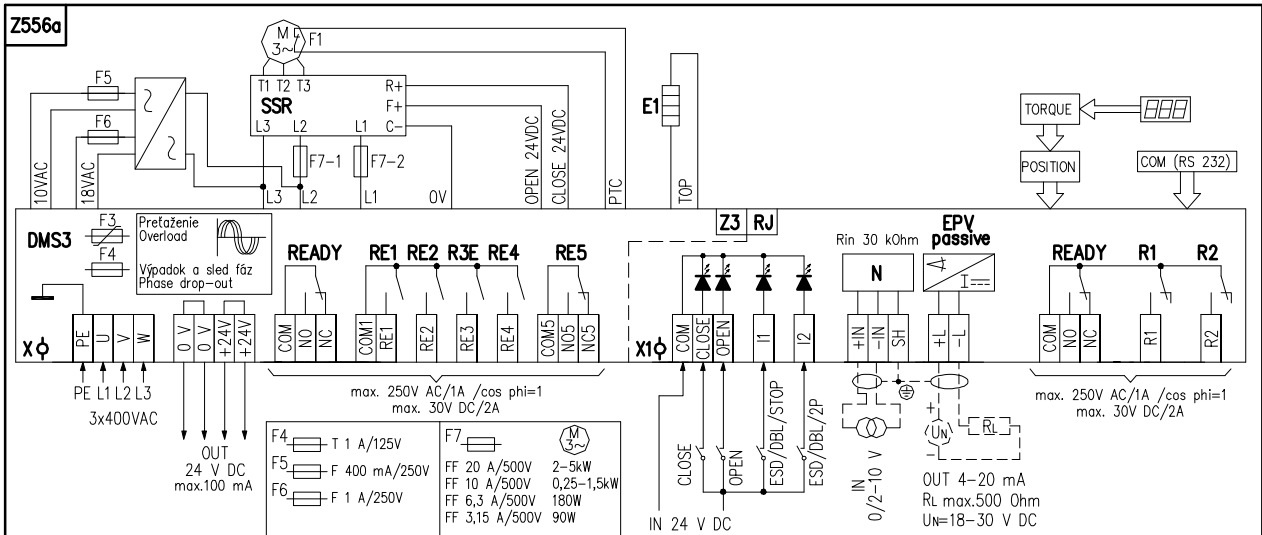

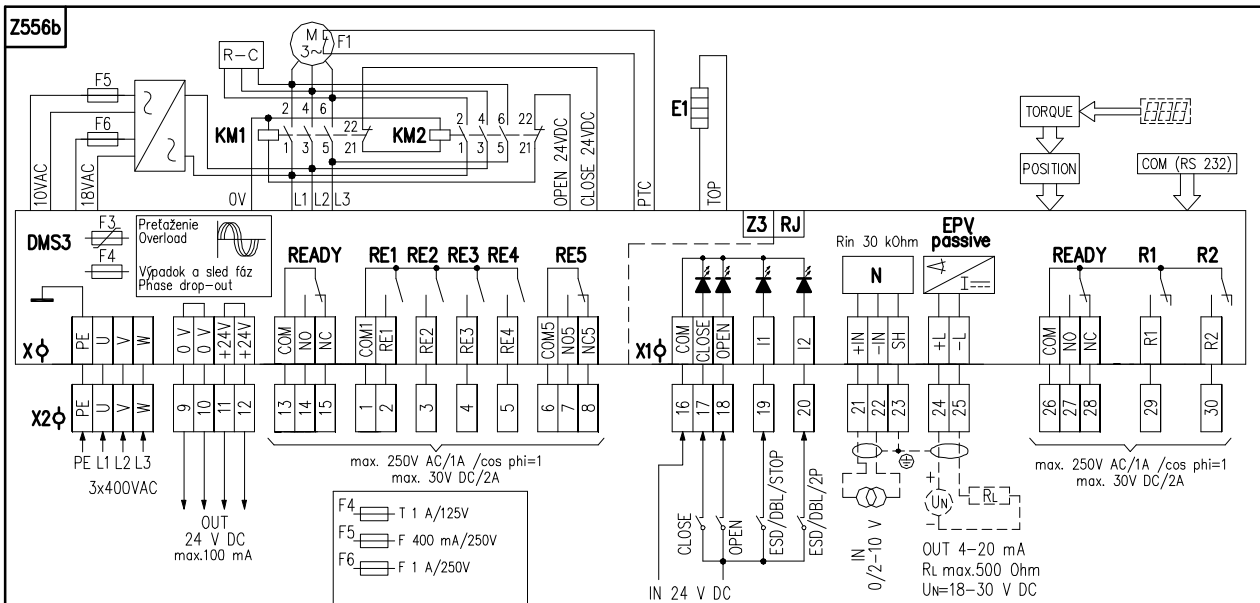
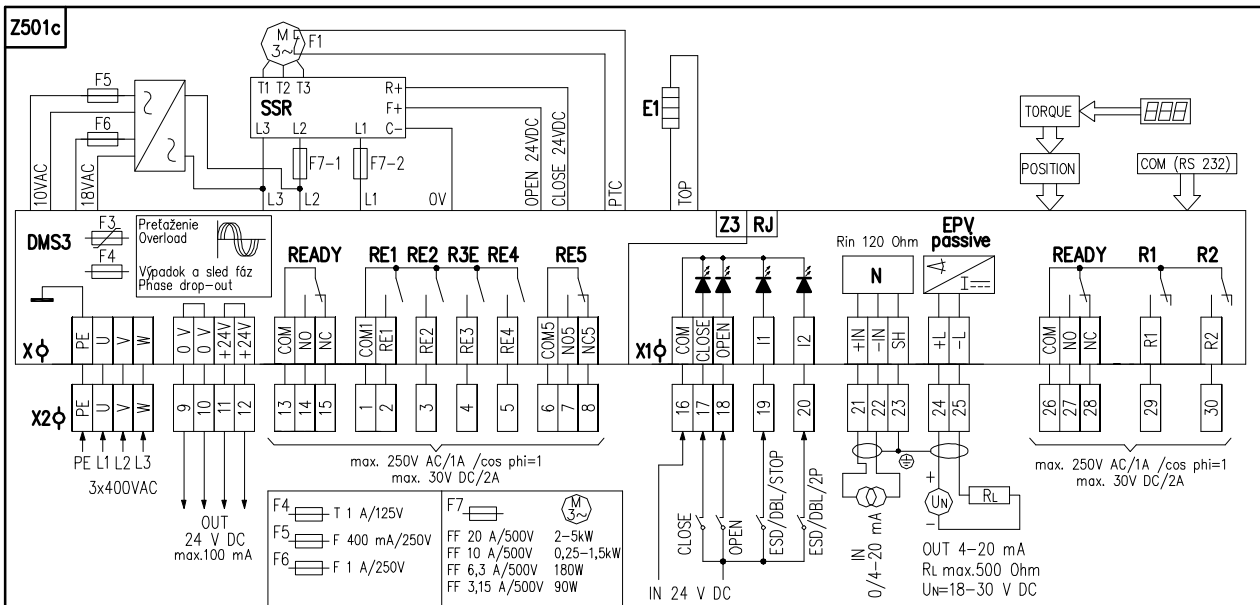
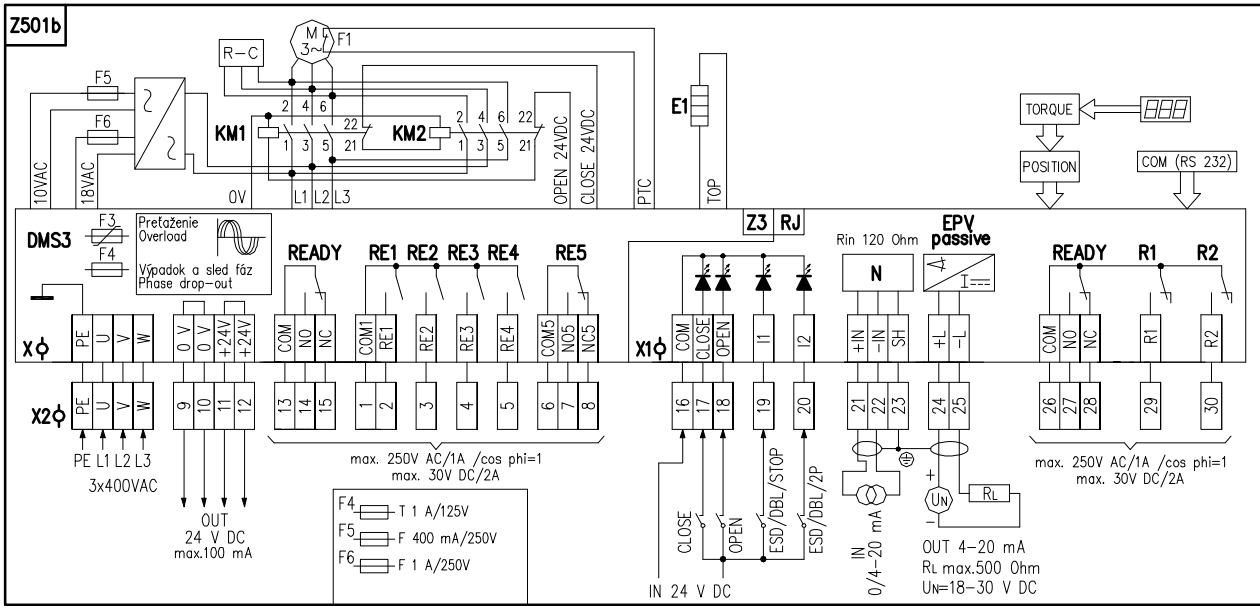

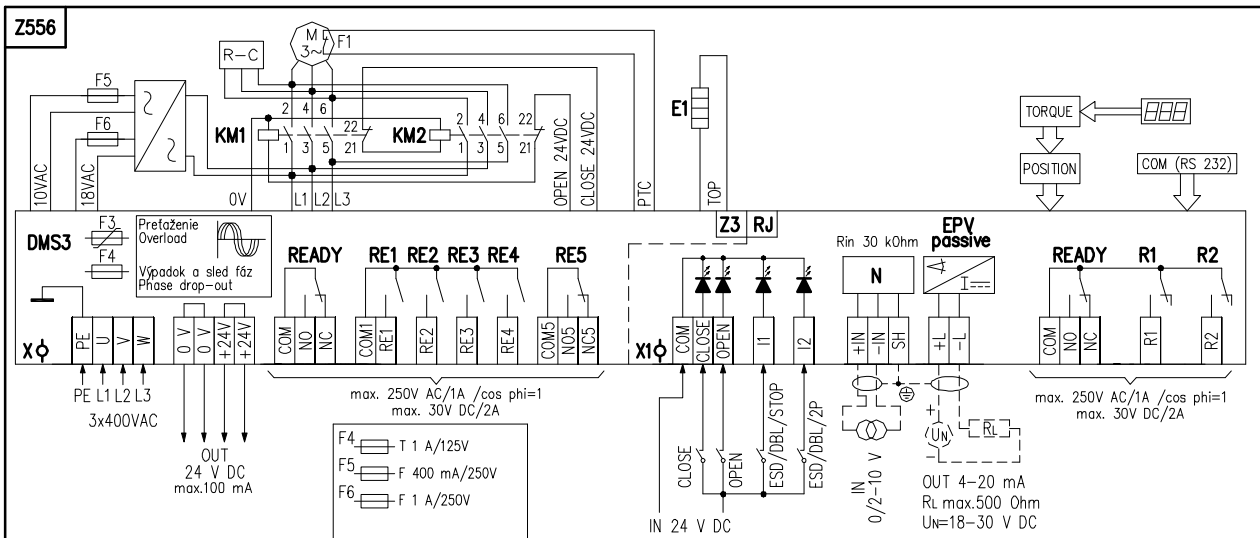
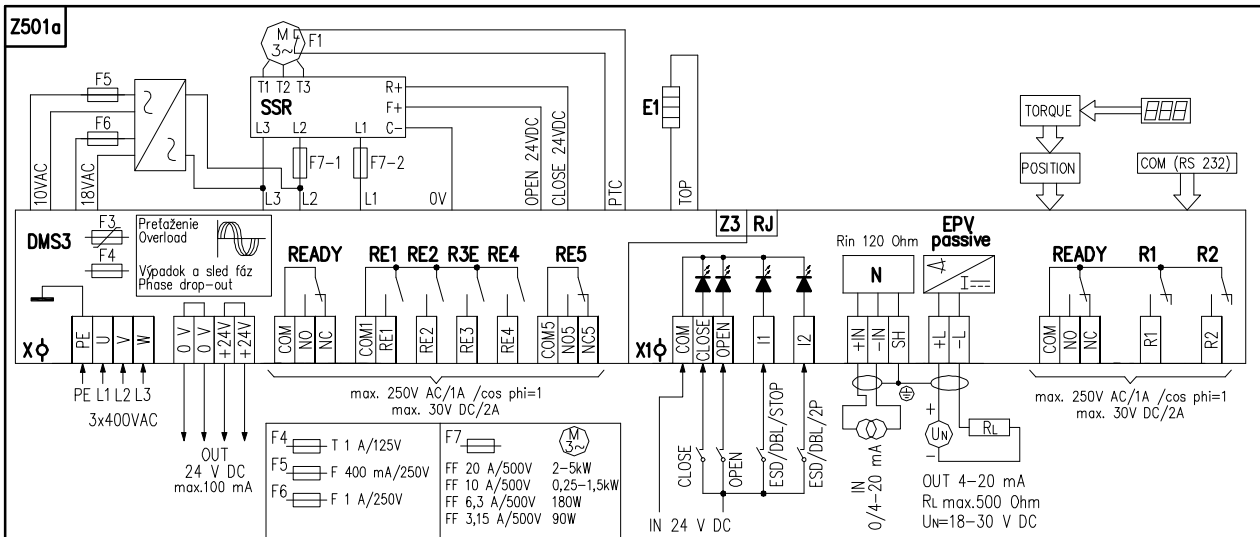
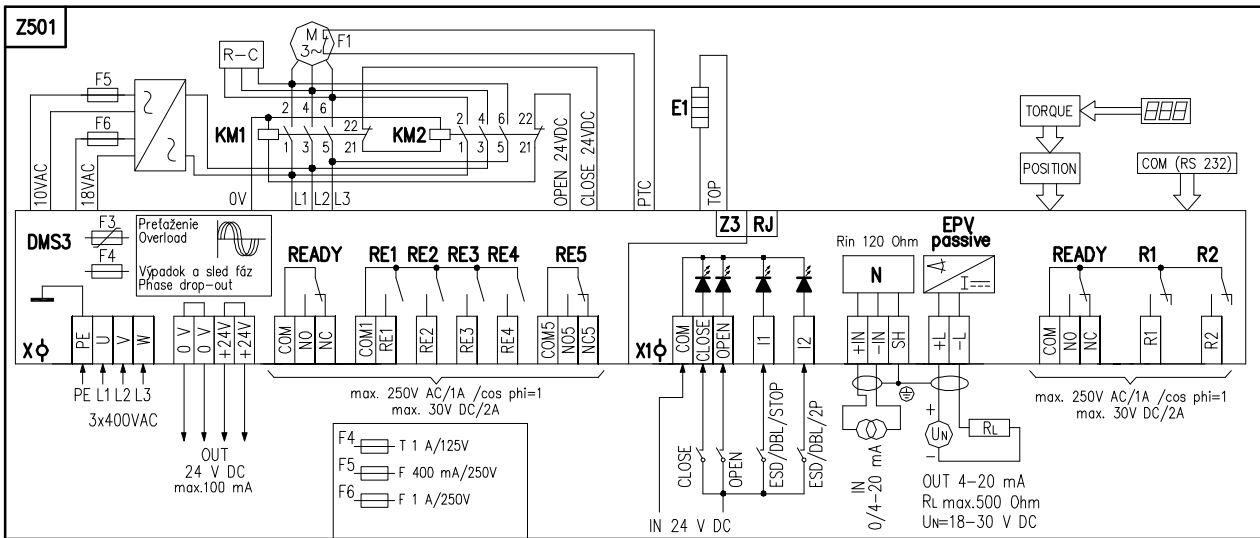

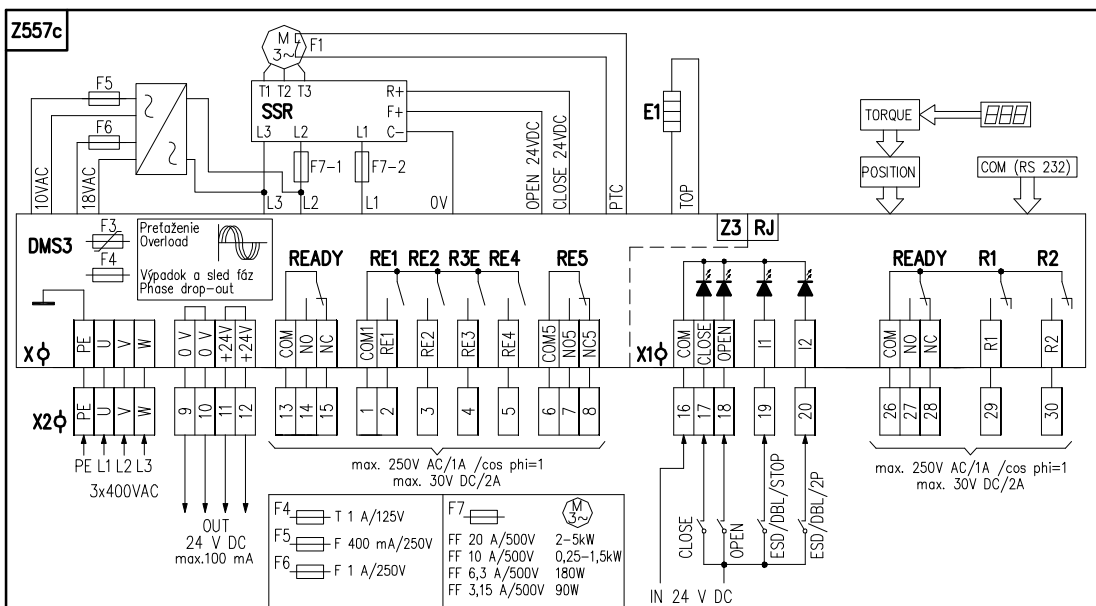
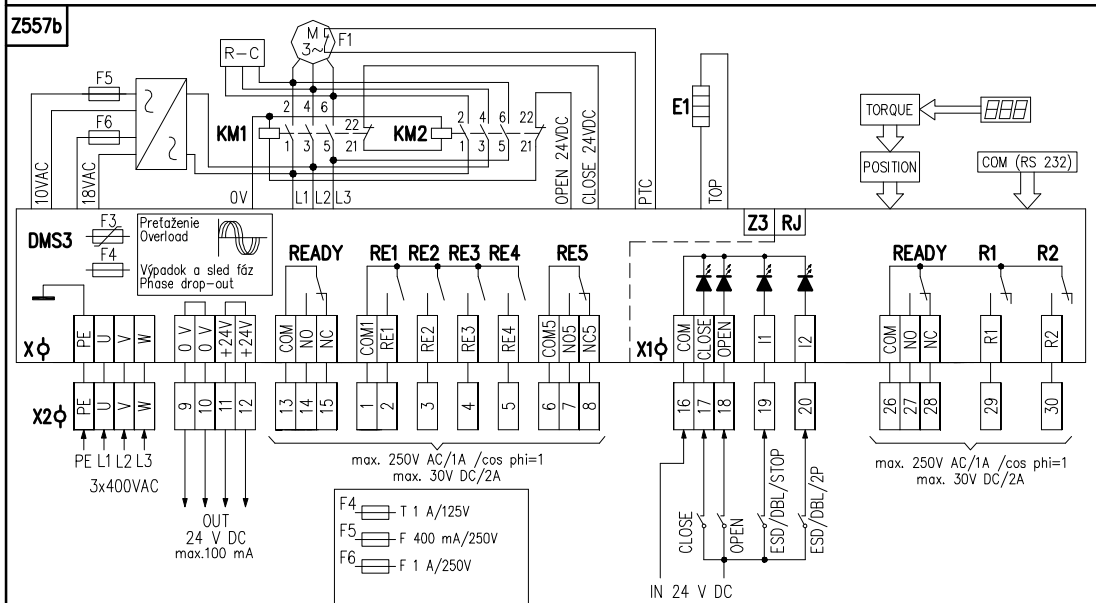
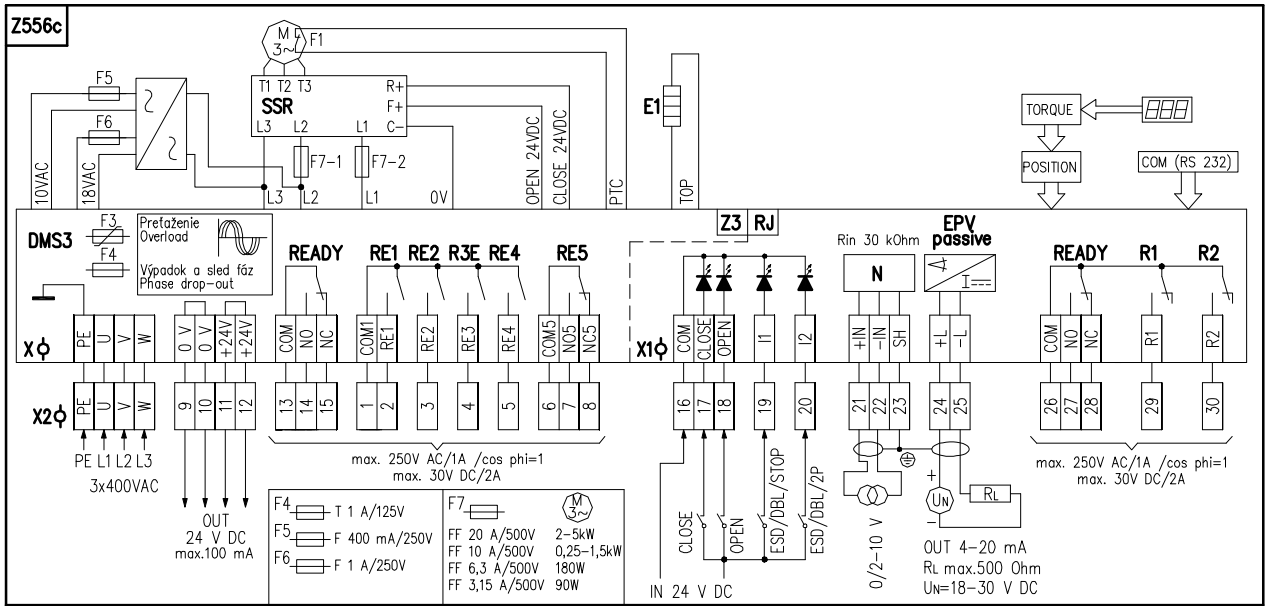

6.1.1 Wiring diagrams with DMS3 electronic control with Modbus/Profibus protocol

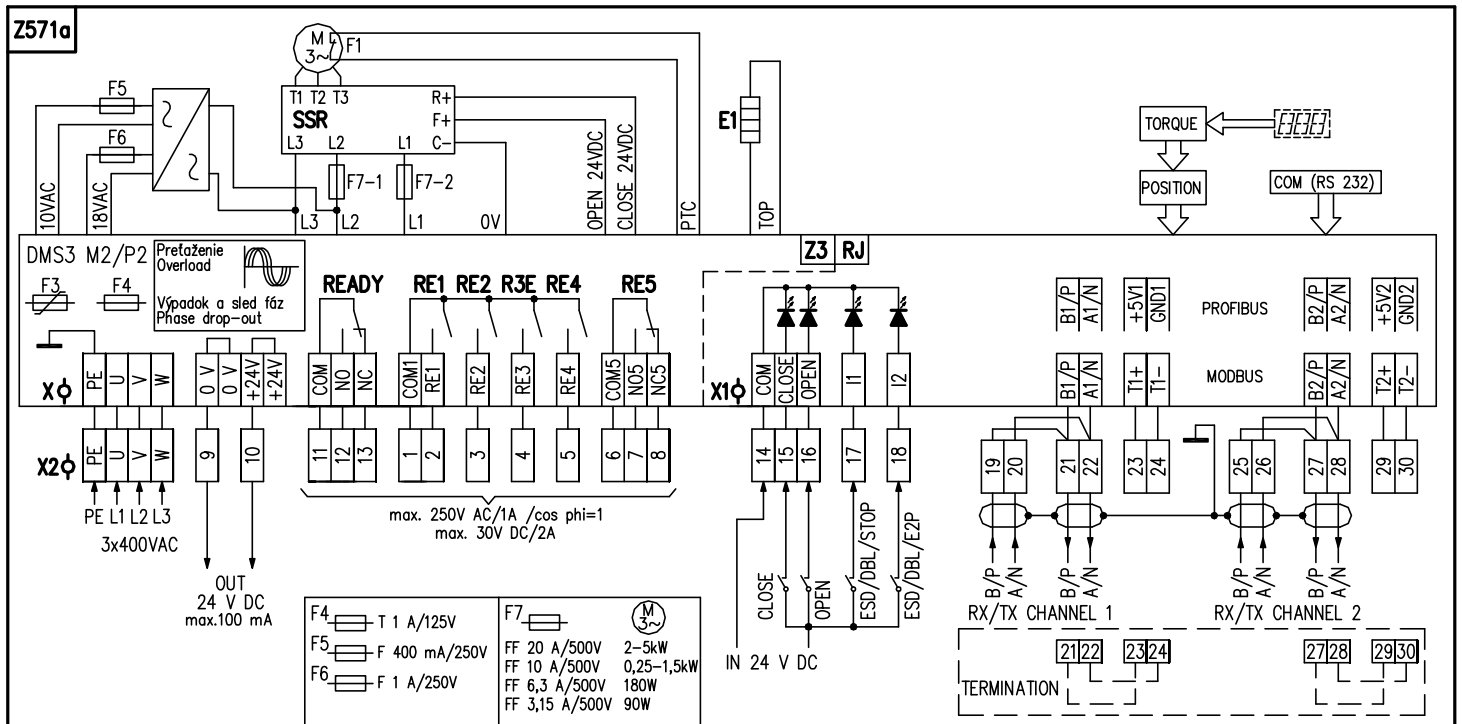
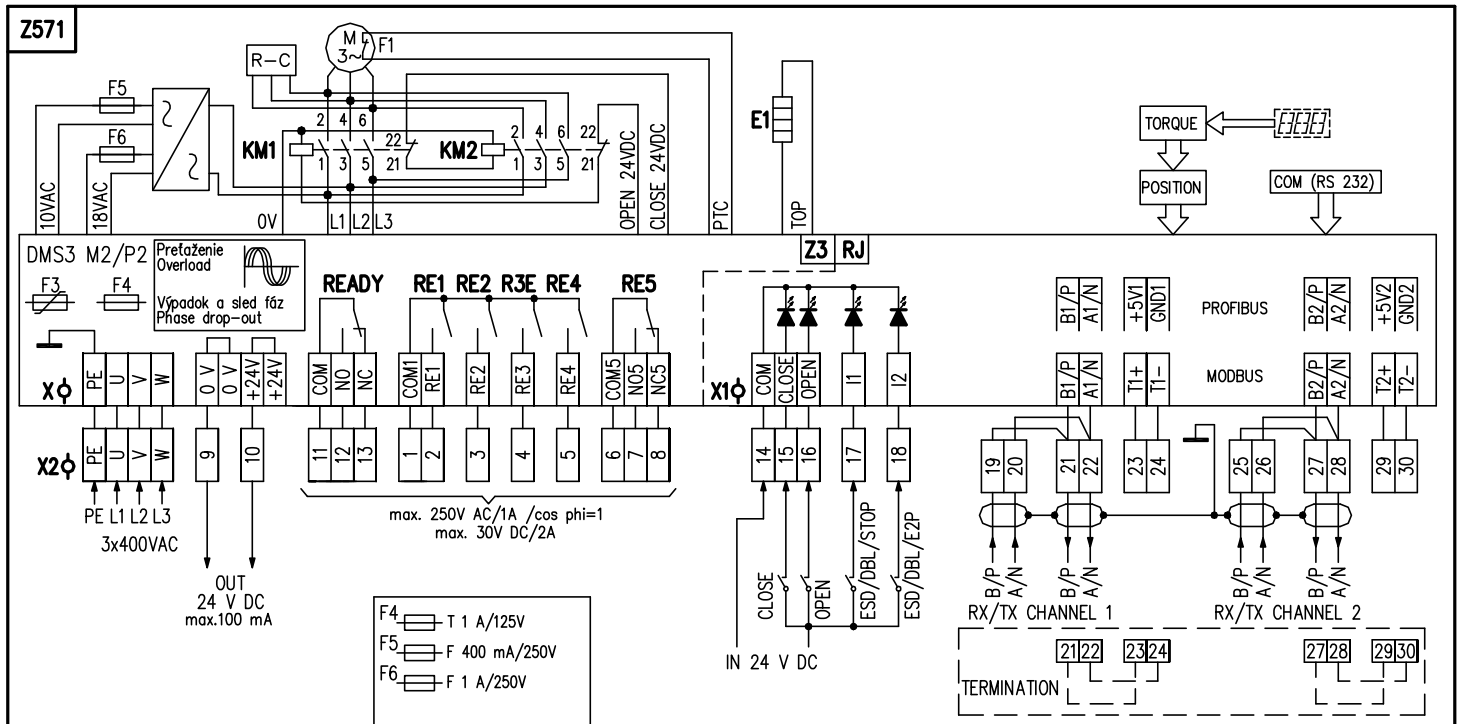

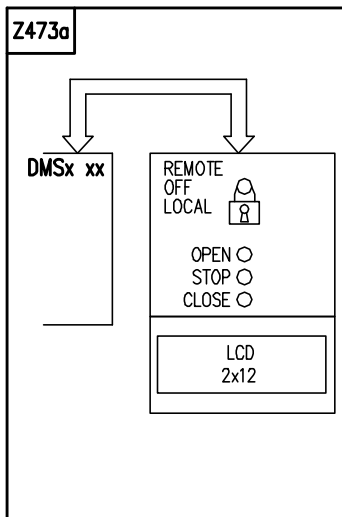
**Legend:**

- Z473a wiring diagram of electric local control
- Z501 wiring diagram of EA MOR 3.XPA resp. MOR 4PA with contactors for the ON/OFF control resp. for analogue input signal 0/4/12 to 20 mA, resp. 4 to 12 mA and output signal 4 to 20 mA
- Z501a wiring diagram of EA MOR 3.XPA resp. MOR 4PA with contactless switching for the ON/OFF control resp. for analogue input signal 0/4/12 to 20 mA, resp. 4 to 12 mA and output signal 4 to 20 mA
- Z556 wiring diagram of EA MOR 3.XPA resp. MOR 4PA with contactors for the ON/OFF control resp. for analogue input signal 0/2 to 10V and output signal 4 to 20 mA
- Z556a wiring diagram of EA MOR 3.XPA resp. MOR 4PA with contactless for the ON/OFF control resp. for analogue input 0/4/12 to 20 mA, resp. 4 to 12 mA and output signal 4 to 20 mA
- Z557 wiring diagram of EA MOR 3.XPA resp. MOR 4PA with contactors for the ON/OFF control
- Z557a wiring diagram of EA MOR 3.XPA resp. MOR 4PA with contactless switching for the ON/OFF control
- Z501b wiring diagram of EA MOR 5PA with contactors for the ON/OFF control resp. for analogue input signal 0/4/12 to 20 mA, resp. 4 to 12 mA and output signal 4 to 20 mA
- Z501c wiring diagram of EA MOR 3.XPA with contactless switching for the ON/OFF control resp. for analogue input signal 0/4/12 to 20 mA, resp. 4 to 12 mA and output signal 4 to 20 mA
- Z556b wiring diagram of EA MOR 5PA with contactors for the ON/OFF control resp. analogue input signal 0/2 to 10 V and output signal 4 to 20 mA
- Z556c wiring diagram of EA MOR 5PA with contactless for the ON/OFF control resp. for analogue input signal 0/2 to 10 V and output signal 4 to 20 mA
- Z557b wiring diagram of EA MOR 5PA with contactless for the ON/OFF control ON/OFF
- Z557c wiring diagram of EA MOR 5PA with contactless for the ON/OFF control
- Z571 wiring diagram of EA MOR X.XPA with interface Modbus/Profibus with contactors
- Z571a wiring diagram of EA MOR X.XPA with interface Modbus/Profibus single Channel with contactless switching
- COM(RS232) possibility for connecting the control unit to a PC
- EPV passive electronic position transmitter is passive with output current signal
- E1 space heater
- F1 motor's thermal protection
- F3-F6 fuse of voltage power supply board
- M three phase electric motor
- N controller
- POSITION position sensing
- R_{in} input resistance
- R_L load resistance
- SSR thyristor unit
- KM1, KM2 reverse contactor
- U_N voltage for EPV
- READY READY relay (free-programmable)
- R1, R2, RE1, RE2, RE3, RE4, RE5 - free-programmable relays
- TORQUE torque sensing
- DMS3 electronic module

X..... voltage supply source terminal board with screw terminals
 X1..... terminal board with screw terminals on the control unit
 X2 terminal board screwless terminals of terminals box.

Terminals for MOR 3.XPA, MOR 4PA for DMS3:

PE, U, V, W – terminals (0,05-2,5 mm²) of supply voltage (3x400 V AC)
 0 V, +24 V – 2x terminals (0,05 - 1 mm²) of output voltage 24 V DC (100 mA)
 COM, CLOSE OPEN, I1, I2 – terminals (0,05 - 1 mm²) of control inputs 24 V /DC on control unit
 +IN, -IN, SH – terminals (0,05 - 1 mm²) of analogue input current resp. voltage signal
 +L, -L – terminals (0,05 - 1 mm²) of output current signal (passive) 4-20 mA
 COM, NO, NC, R1, R2 – terminals (0,05 – 1,5 mm²) of relay READY, R1, R2 on control unit
 COM, NO, NC, COM1, RE1, RE2, RE3, RE4, COM5, NO, NC – terminals (0,05 – 1,5 mm²) of relay
 READY, RE1, RE2, RE3, RE4, RE5 on power supply board

Terminals for MOR 5PA for DMS3:

- screwless terminals are in separately terminal box. cross-section of connection wire 0,08 - 2,5 mm²
 PE, U, V, W – terminals of supply voltage (3x400 V AC)
 9,10,11,12 (0 V, +24 V) – 2x terminals of output voltage 24 V DC (100 mA)
 16,17,18,19,20 (COM, CLOSE OPEN, I1, I2) – terminals of control inputs 24 V DC of control unit
 21,22,23 (+IN, -IN, SH) – terminals of analogue input current resp. voltage signal
 24,25 (+L, -L) – terminals of output current signal (passive) 4-20 mA
 26,27,28,29,30 (COM, NO, NC, R1, R2) – terminals of relay READY, R1, R2 on control unit
 13,14,15,1,2,3,4,5,6,7,8 (COM, NO, NC, COM1, RE1, RE2, RE3, RE4, COM5, NO, NC) – terminals of
 relay READY, RE1, RE2, RE3, RE4, RE5 on power supply board.

Terminals for DMS3 Modbus/Profibus:

- screwless terminals are in separately terminal box. cross-section of connection wire 0,08 - 2,5 mm²
 PE,,U,V,W - terminals of supply voltage 3x400 V AC
 1,2,3,4,5,6,7,8,11,12,13 – terminals of relay READY, RE1, RE2, RE3, RE4, RE5 on the source board
 9,10 – terminals of output voltage 24 V DC (100 mA)
 14,15,16,17,18 – terminals of ovládacích vstupov 24 V DC
 19,20,21,22,23,24 – terminals Single channel interface Modbus/Profibus
 25,26,27,28,29,30 – terminals Duo channel interface Modbus/Profibus

Note 1:

Program possibilities for **R1, R2, RE1, RE2, RE3, RE4, RE5** relays: **DISABLED**, open position, close position, torque-open, torque – close, torque open or torque close, torque open or position open, torque close or position close, open, close, movement, movement flasher, to position, from position, warning, remote control, local control, control shut off, relay READY

Program possibilities for **READY** relay: errors, errors or warnings, errors or no remote, errors or warnings or no remote

Program possibilities for output signal (from **EPV** passive): 4 to 20 mA, 20 to 4 mA

Control programme options (regulating)(not valid for with Modbus/Profibus protocol): 2P, 3P, 3P/2P switched over to I2

Program possibilities for **input control signal (N)**: 4 to 20 mA, (2 to 10 V), 20 to 4 mA, (10 to 2 V), 0 to 20 mA, (0 to 10 V), 20 to 0 mA. (10 to 0 V), 4 to 12 mA, 12 to 4 mA, 12 to 20 mA, 20 to 12 mA

Program possibilities - for Modbus protocol

address – 1 247

baudrate [bit/s] – 1200, 2400, 4800, 9600, 19200, 38400, 57600, 115200

parity – even, odd, No

redundancy – off, Cable, Component, Repeater

connect time [s] – 0,1 25,5s

Program possibilities - for Profibus protocol

Address 1 – 1 ... 126

Address 2 – 1126

Redundancy: - Off, Simple

Program possibilities **for inputs I1: DISABLED**, ESD, DBL (local releasing, remote releasing), (not valid for EA's without local control), STOP.

Program possibilities **for inputs I2: DISABLED**, ESD, DBL (local releasing, remote releasing), STOP 2P, resp. E2P (when controller is switch on)(for control programme option 3P/2P I2, resp. for active communication through Modbus protocol) allows control using the binary 24V DC inputs with I2 input activated.

Program possibilities of FAILURE REACTION ESD: OPEN, CLOSE, STOP, SAFE POSITION.

The identical functions cannot be set on I1 & I2 inputs in addition to the disabled state (e.g., if the ESD function is set on I1 input, it is not possible to select the (ESD) function on I2 input at the same time.

Relay READY on the control unit is doubled with relay READY on the power supply board.

Relay R1 and relay R2 on the control unit is doubled with relay RE1 and relay RE2 on the power supply board.

6.2 Dimension drawings and mechanic connections

6.2.1 Dimension drawings for EA MOR 3PA

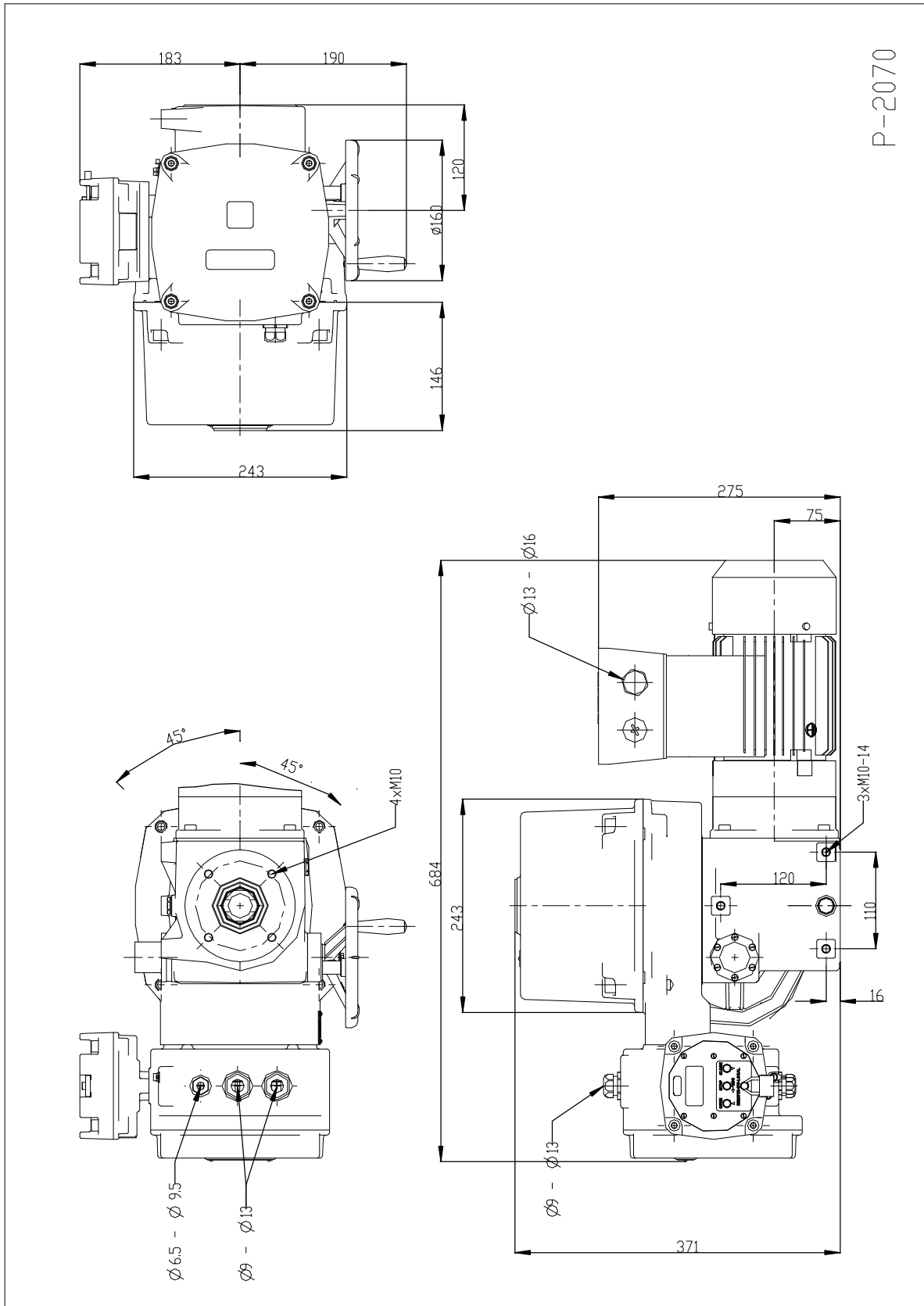

Mechanic connections for EA MOR 3PA without connect adapter

4 x tooth

F10 – shape D

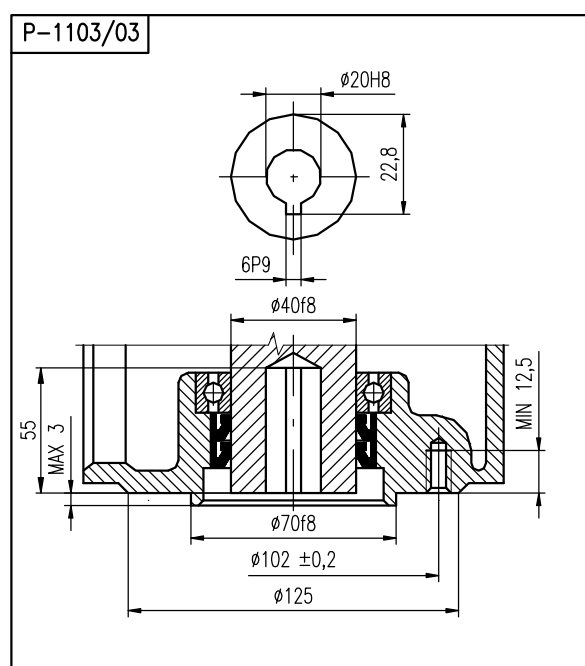
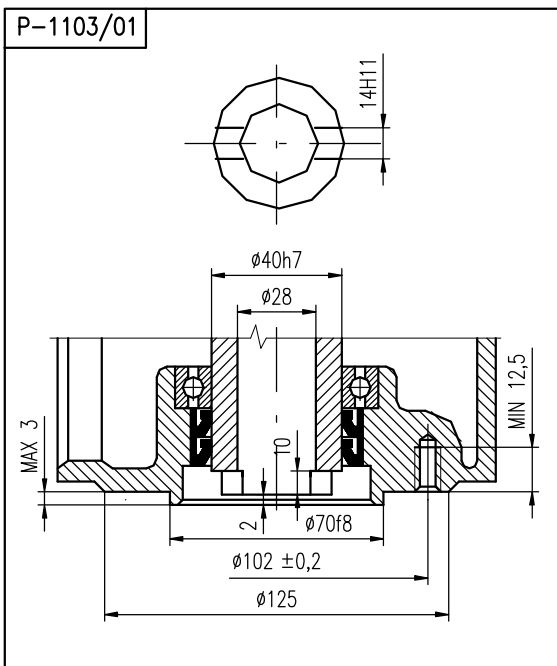
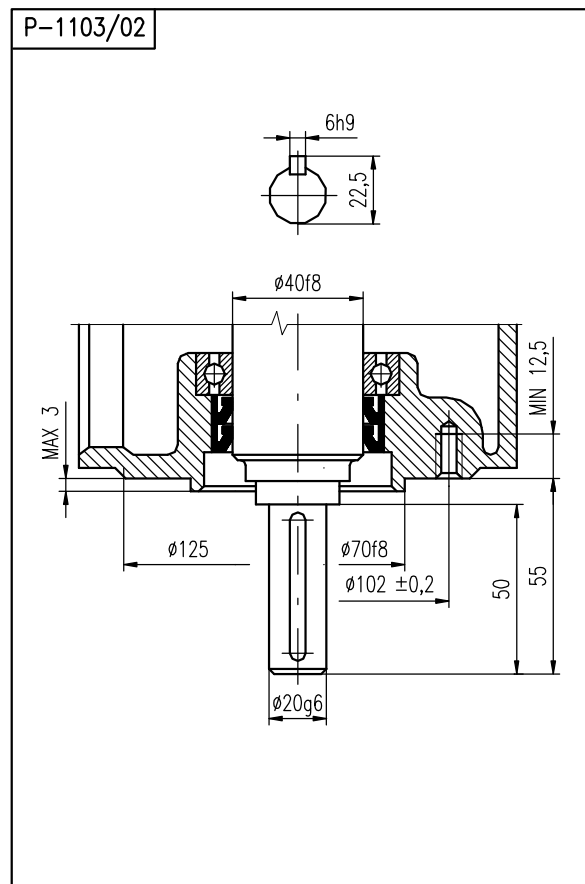
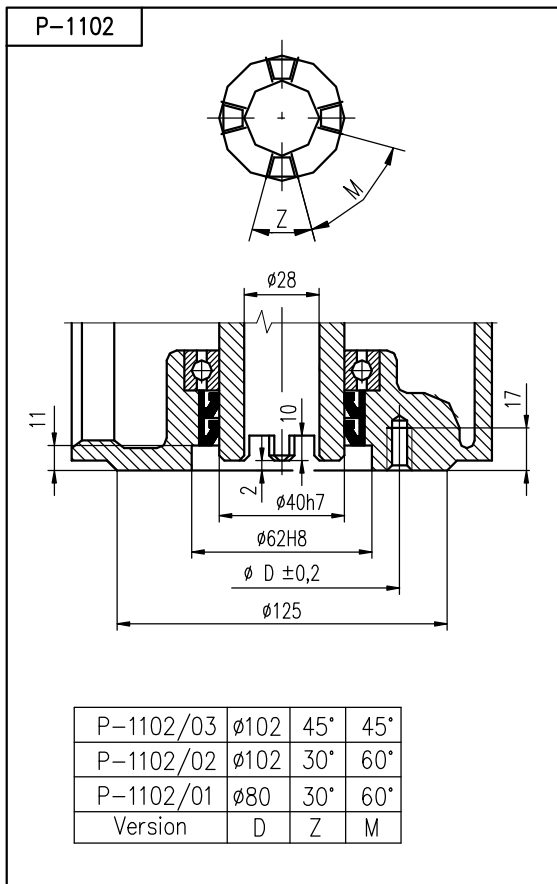

F10 – shape C; NON-STANDARD

F10 – shape E; ISO 5210

Mechanic connections for EA MOR 3PA with connect adapter
 F10 – shape A

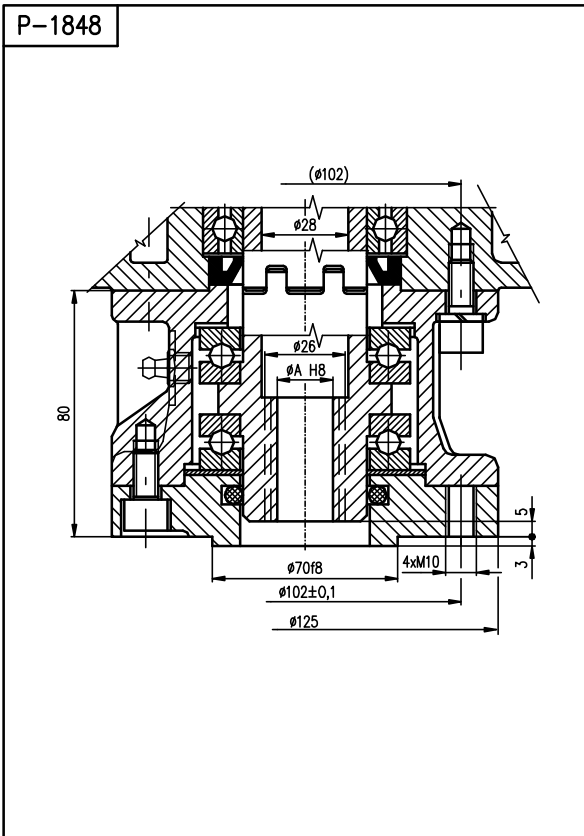

F14 – shape C

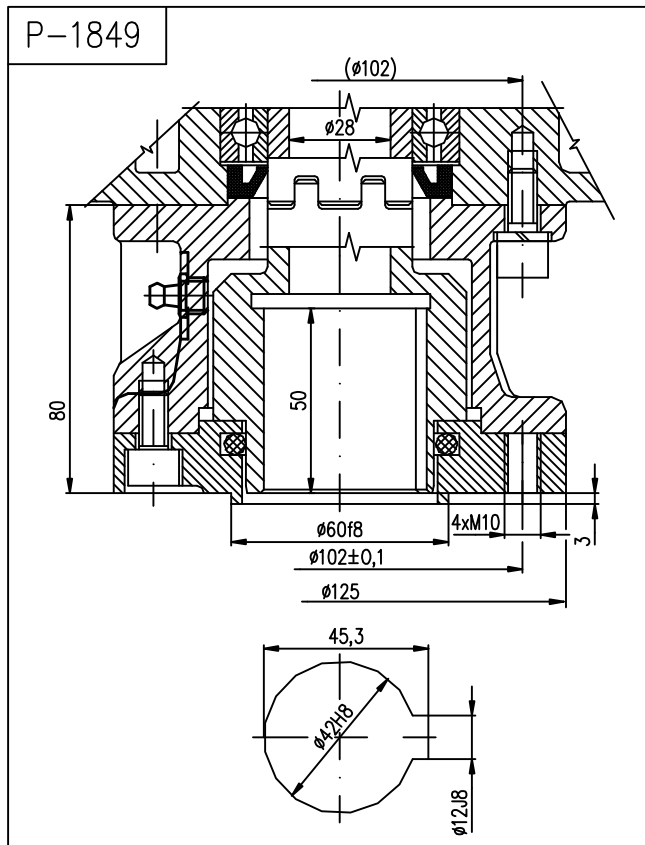
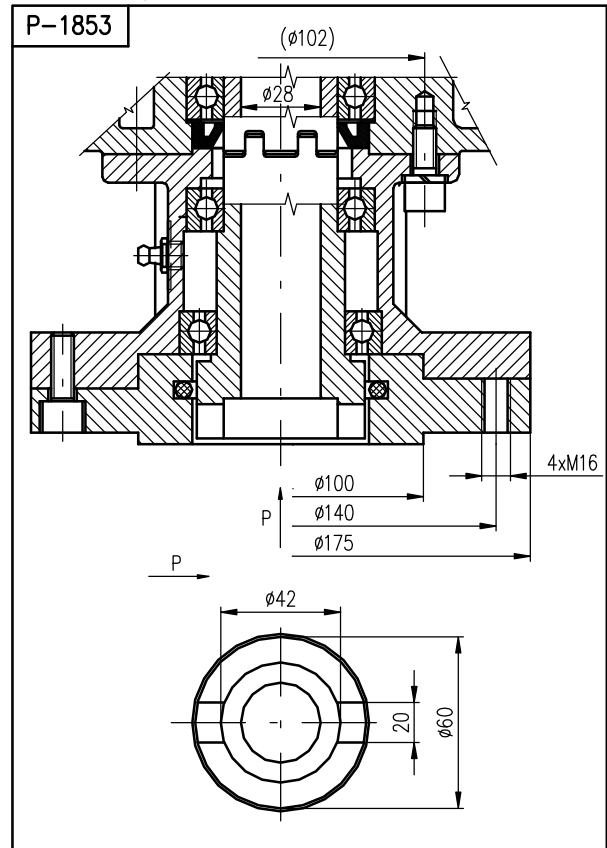

F10 – shape B1; ISO 5210

6.2.2 Dimension drawings for EA MOR 3.4PA

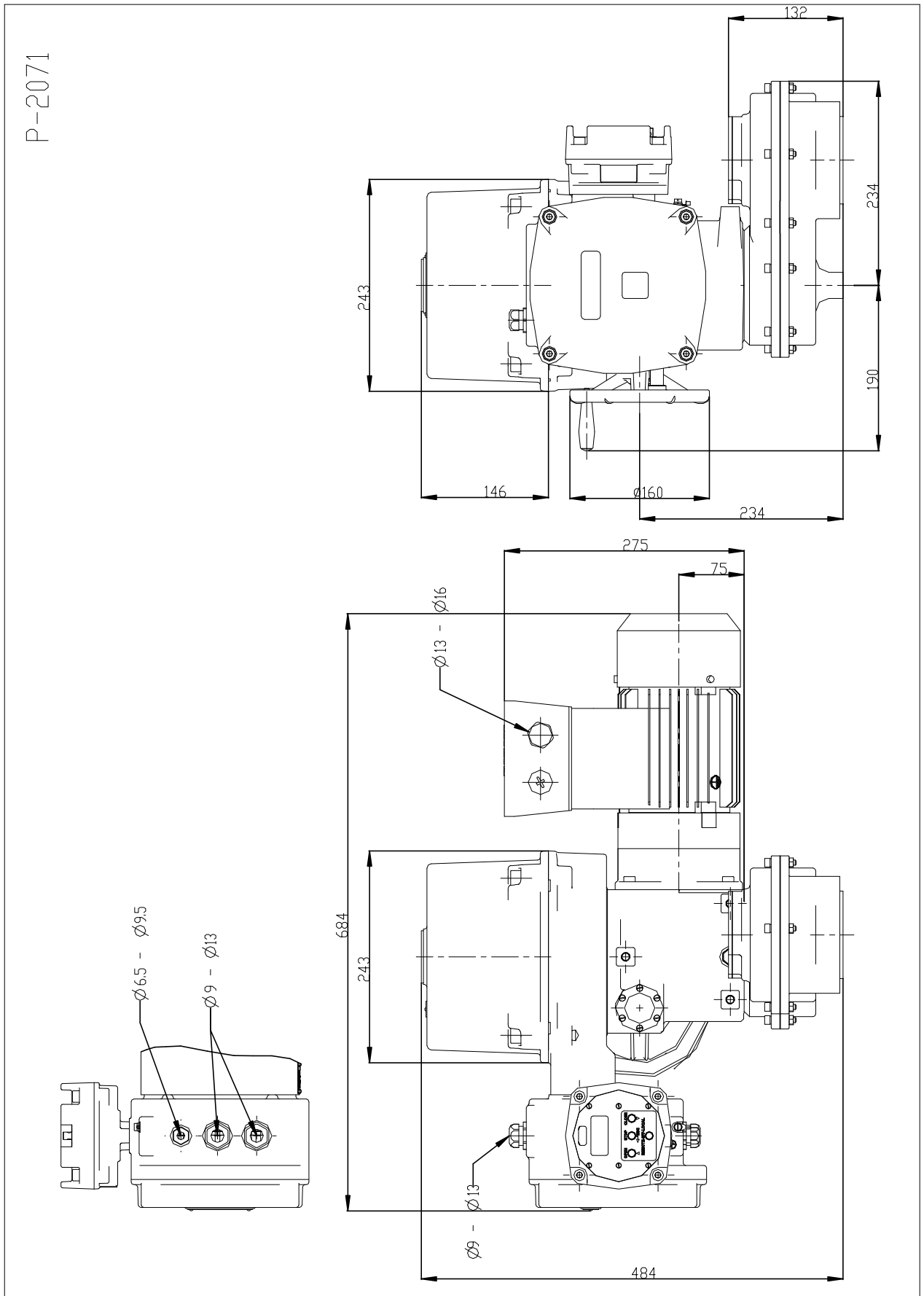

Mechanic connections for EA MOR 3.4PA without connect adapter

shape C; NON-STANDARD

5 tooth 35°/37° ; GOST R 555 10

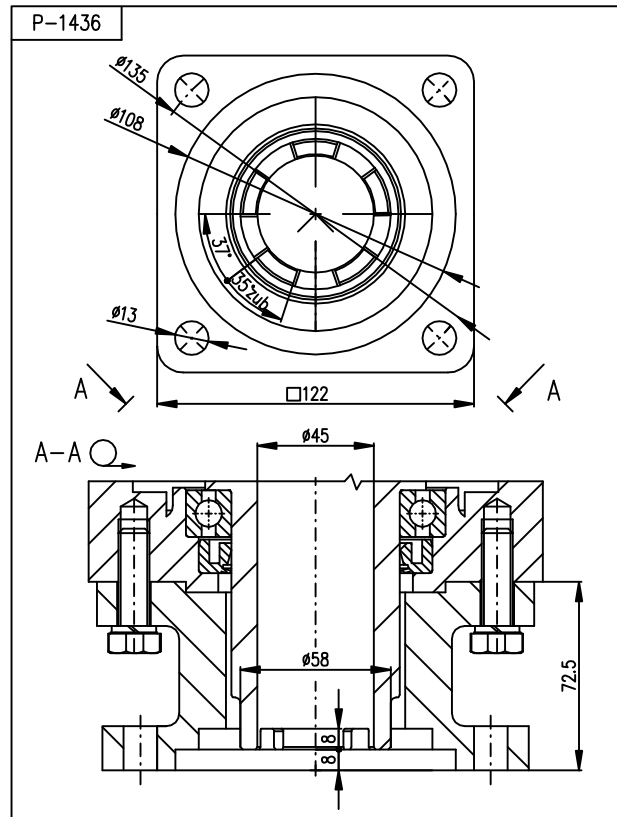
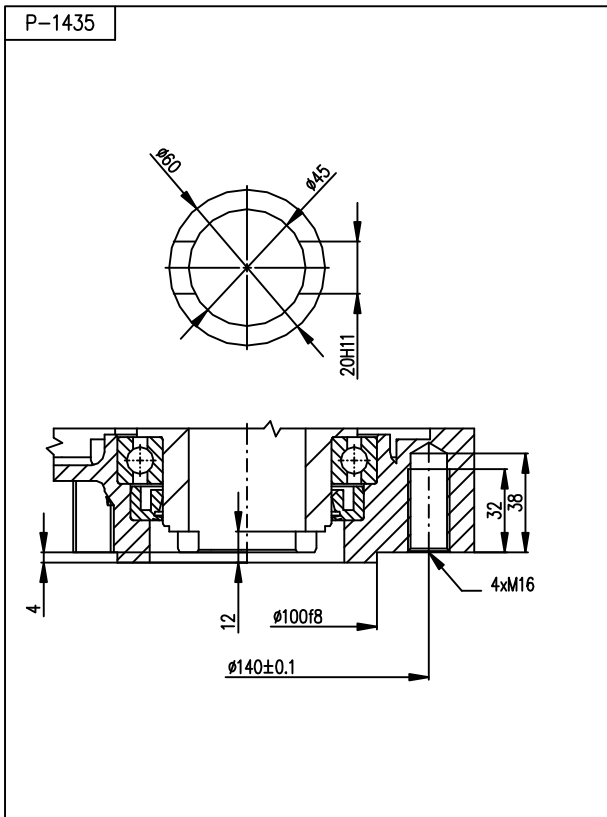

shape D

shape B2; B3; ISO 5210

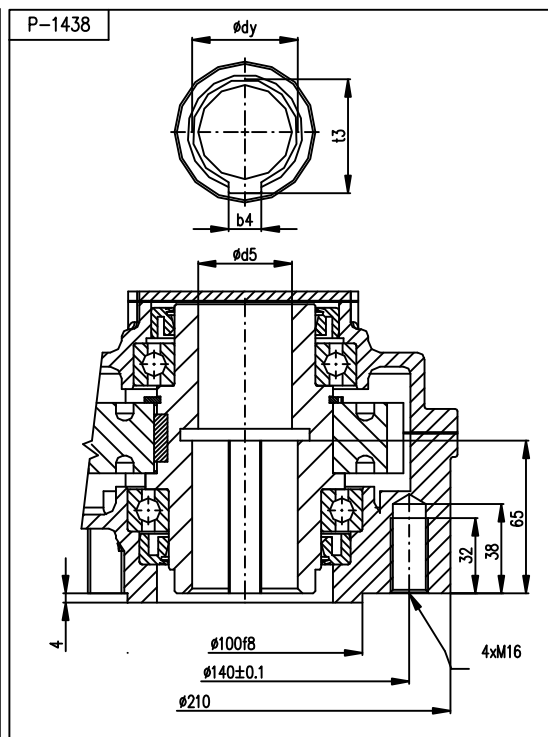
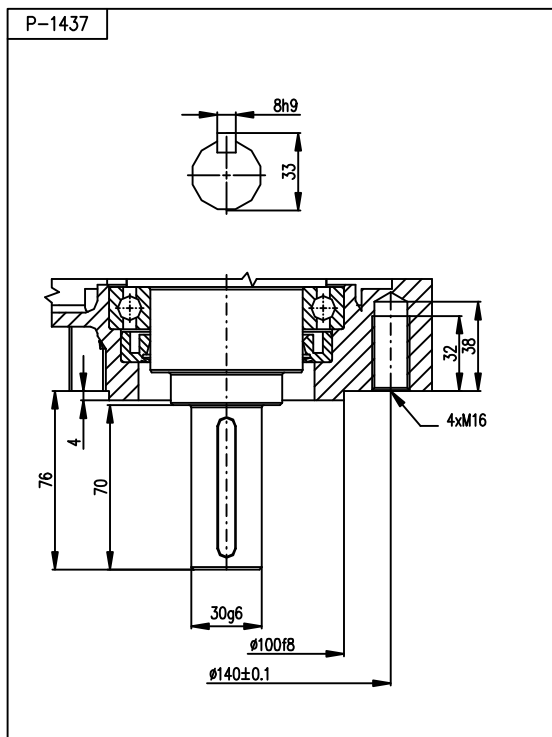

P-1438/N	45	40	14	48.6
P-1438/L	30	-	8	33.3
VERSION	dyH9	d5	b4Js9	t3

Mechanic connections for EA MOR 3.4PA with connect adapter

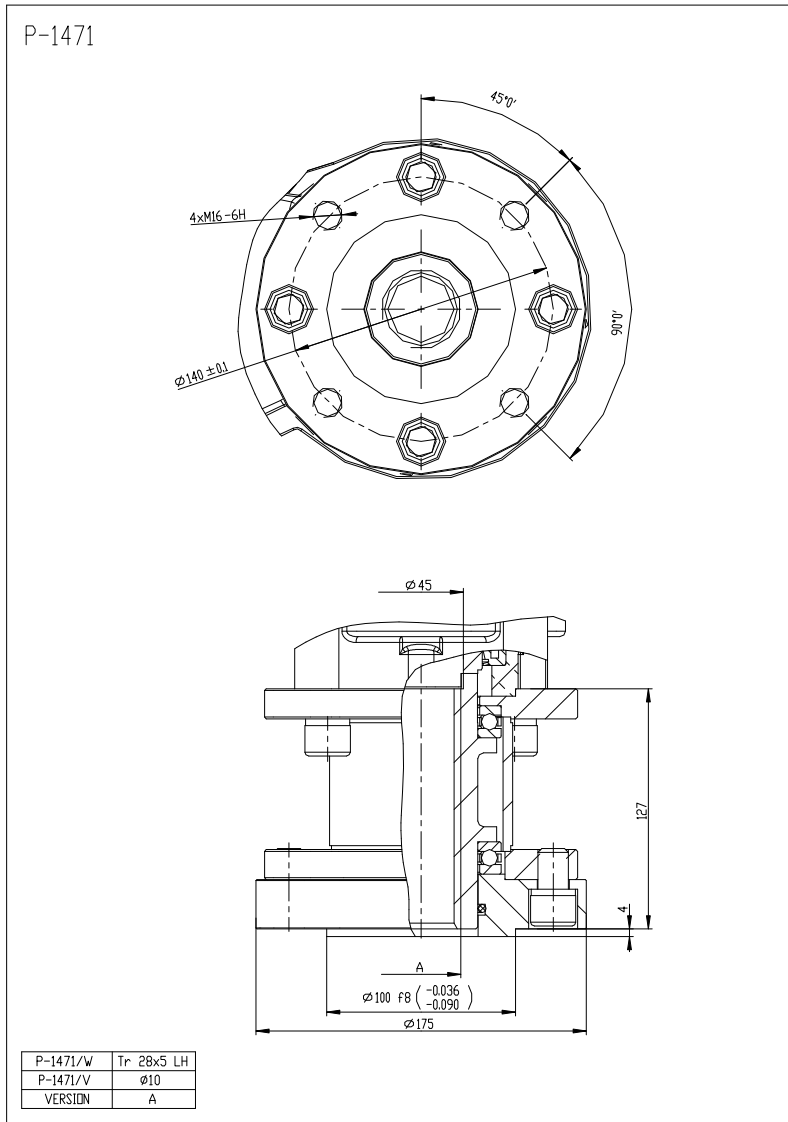

P-1463

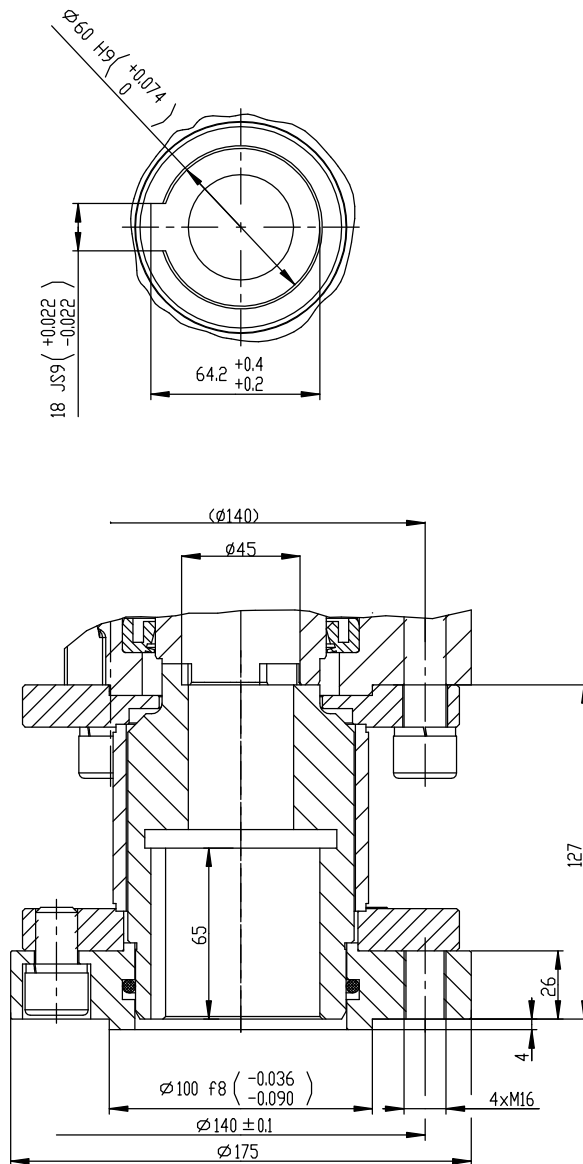

6.2.3 Dimension drawings for EA MOR 3.5PA

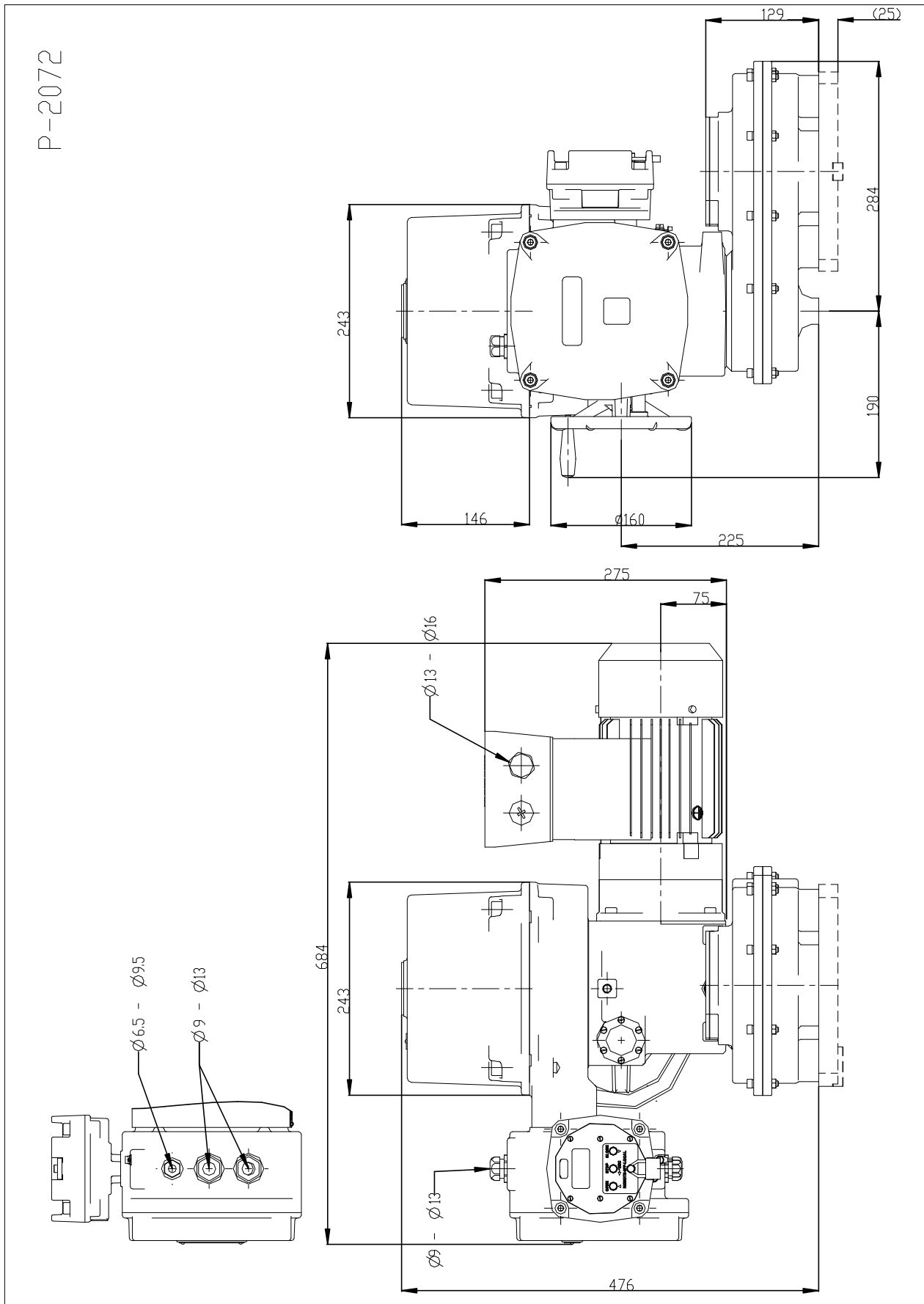

Mechanic connections EA MOR 3.5PA without connect adapter

shape C; NON-STANDARD

shape 5 tooth 35°/37°; GOST R 555 10

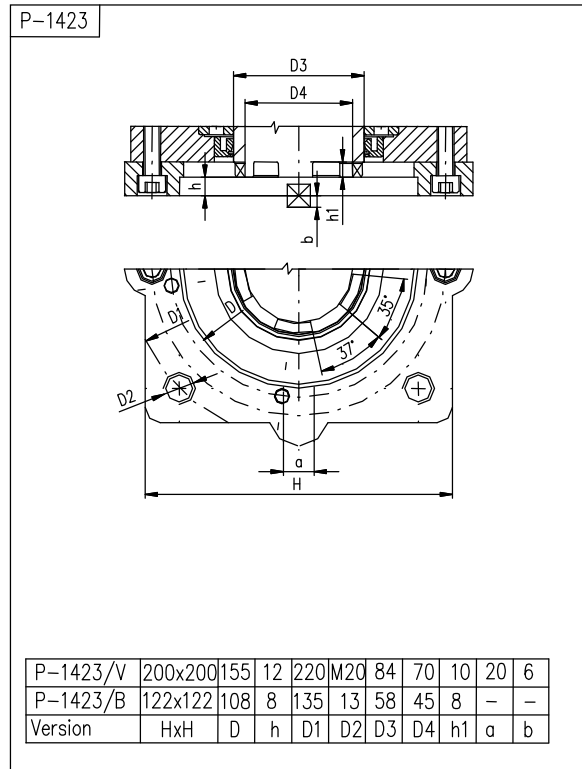
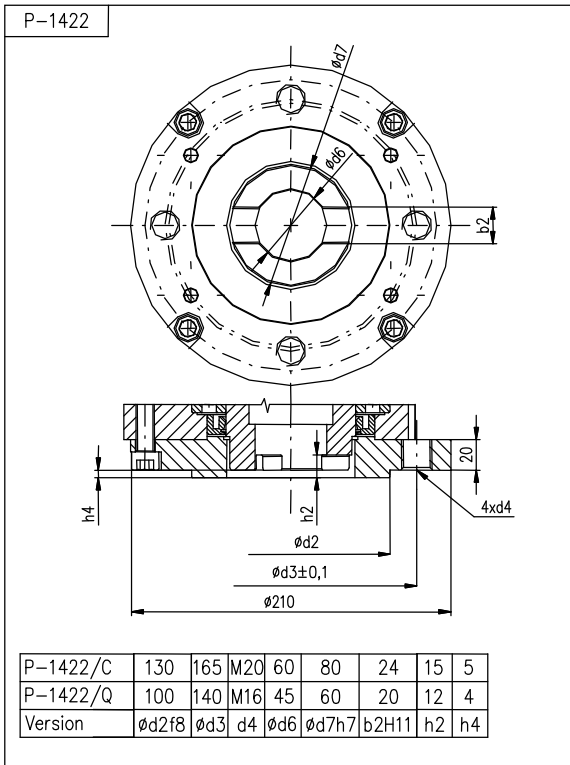

shape D

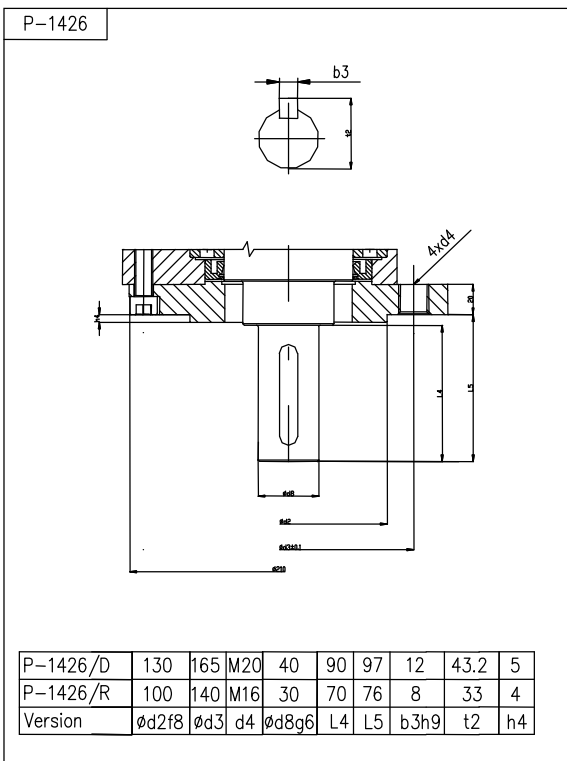

shape B1; B2, B3; ISO 5210

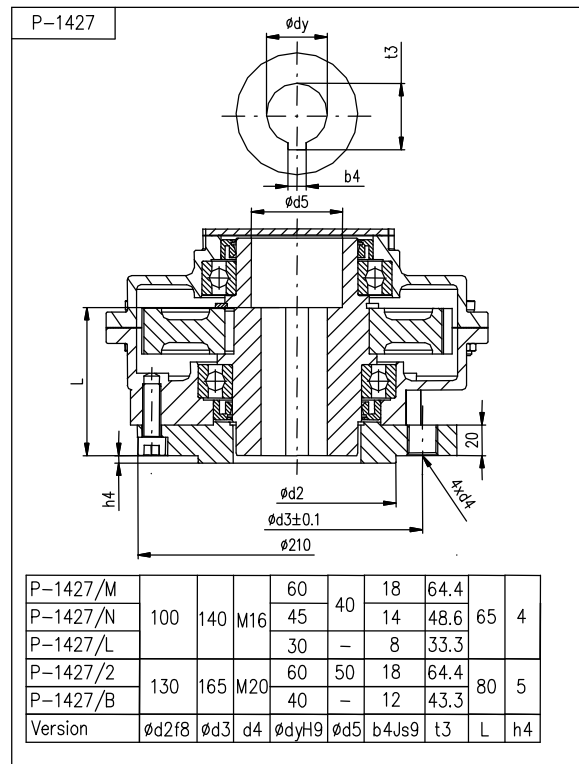

Mechanic connections for EA MOR 3.5PA with connect adapter

F16 – shape A; ISO 5210

F14 – shape A; ISO 5210

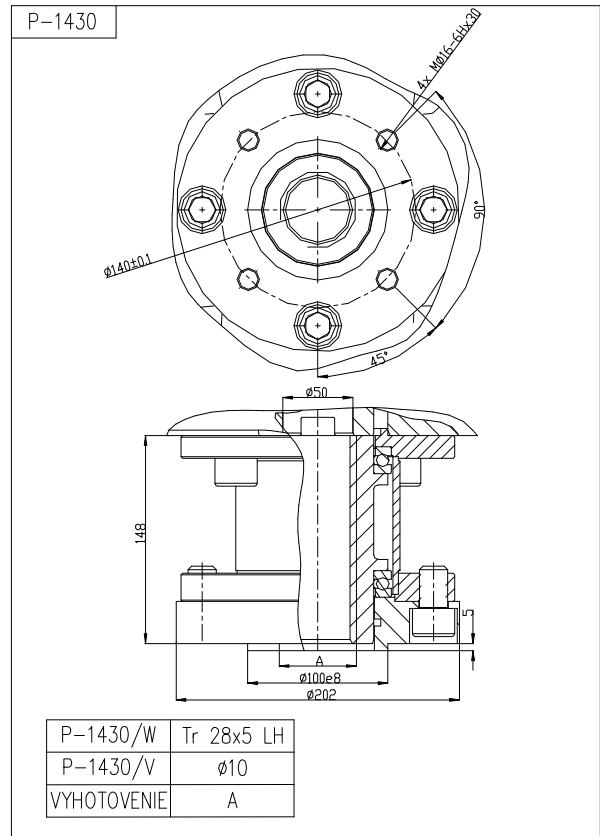
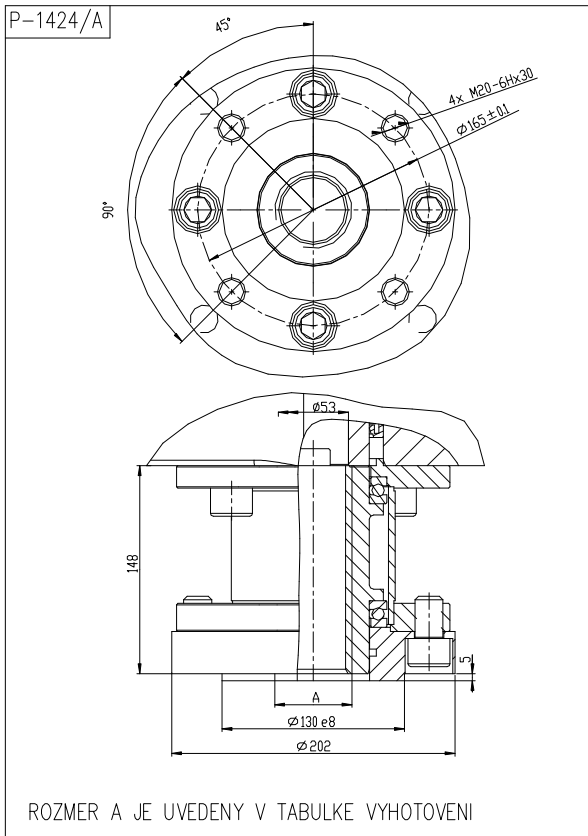

EA MOR 3PA, MOR 3.4PA, MOR 3.5PA with local control

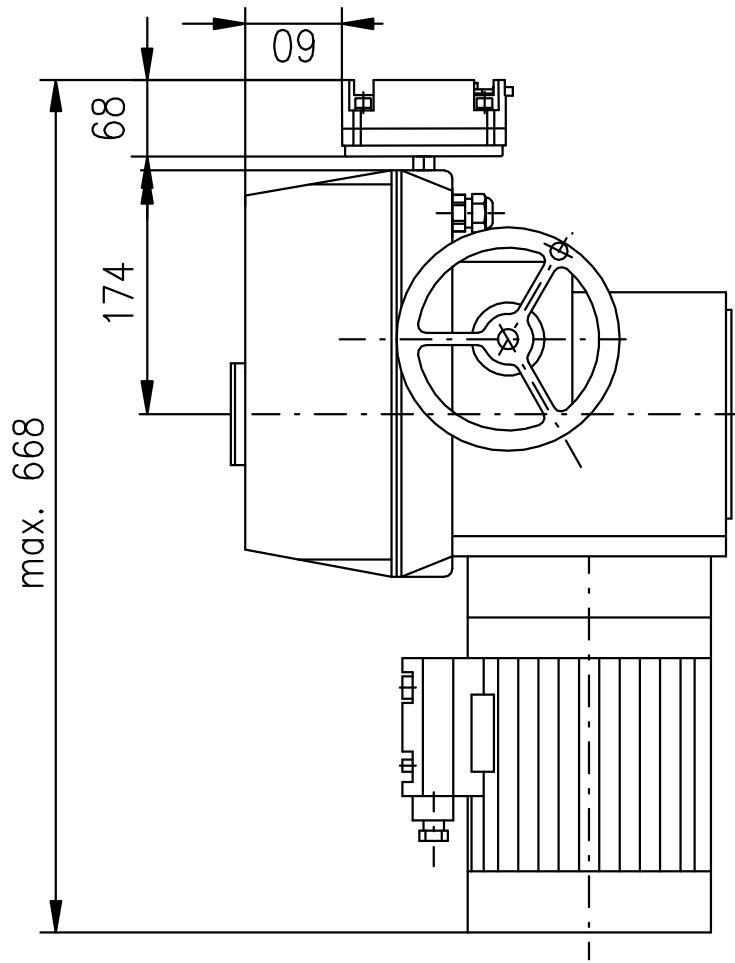

P-2069

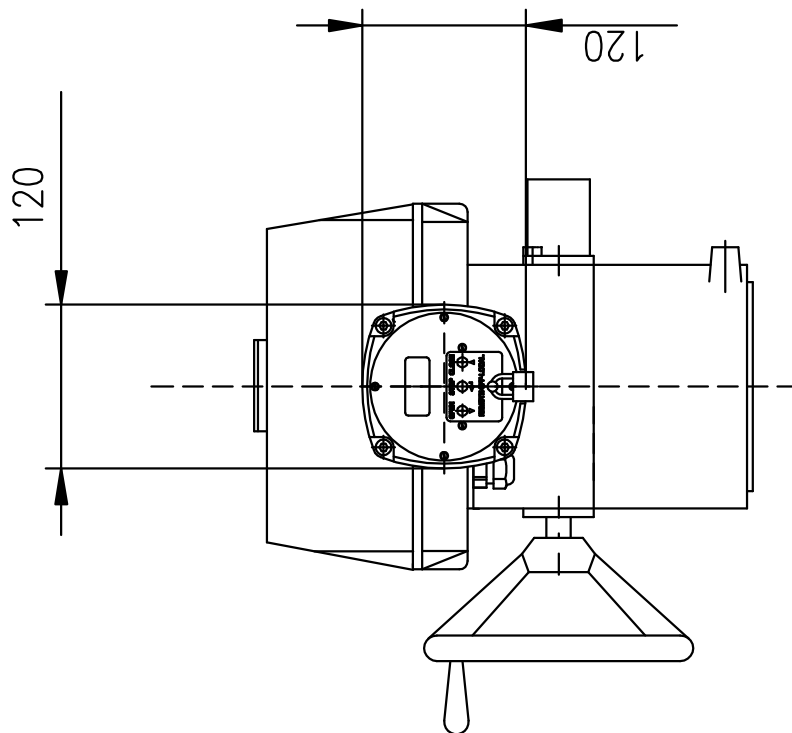

6.2.4 Dimension drawings for EA MOR 5PA

P-1424	EA	MOR 5PA Connections ISO 5210, NON-STANDARD F16
P-1424/A	EA	MOR 5PA ISO 5210, shape A
P-1424/B	EA	MOR 5PA ISO 5210, shape B3
P-1424/C	EA	MOR 5PA NON-STANDARD shape C
P-1424/D	EA	MOR 5PA shape D
P-1425	EA	MOR 5PA Connections GOST R 55510-2013 ϕ 220/4xM20
P-1425/1	EA	MOR 5PA shape five toot 35°/37°

Dimensional connection drawings according to ISO 5210, NON-STANDARD F16

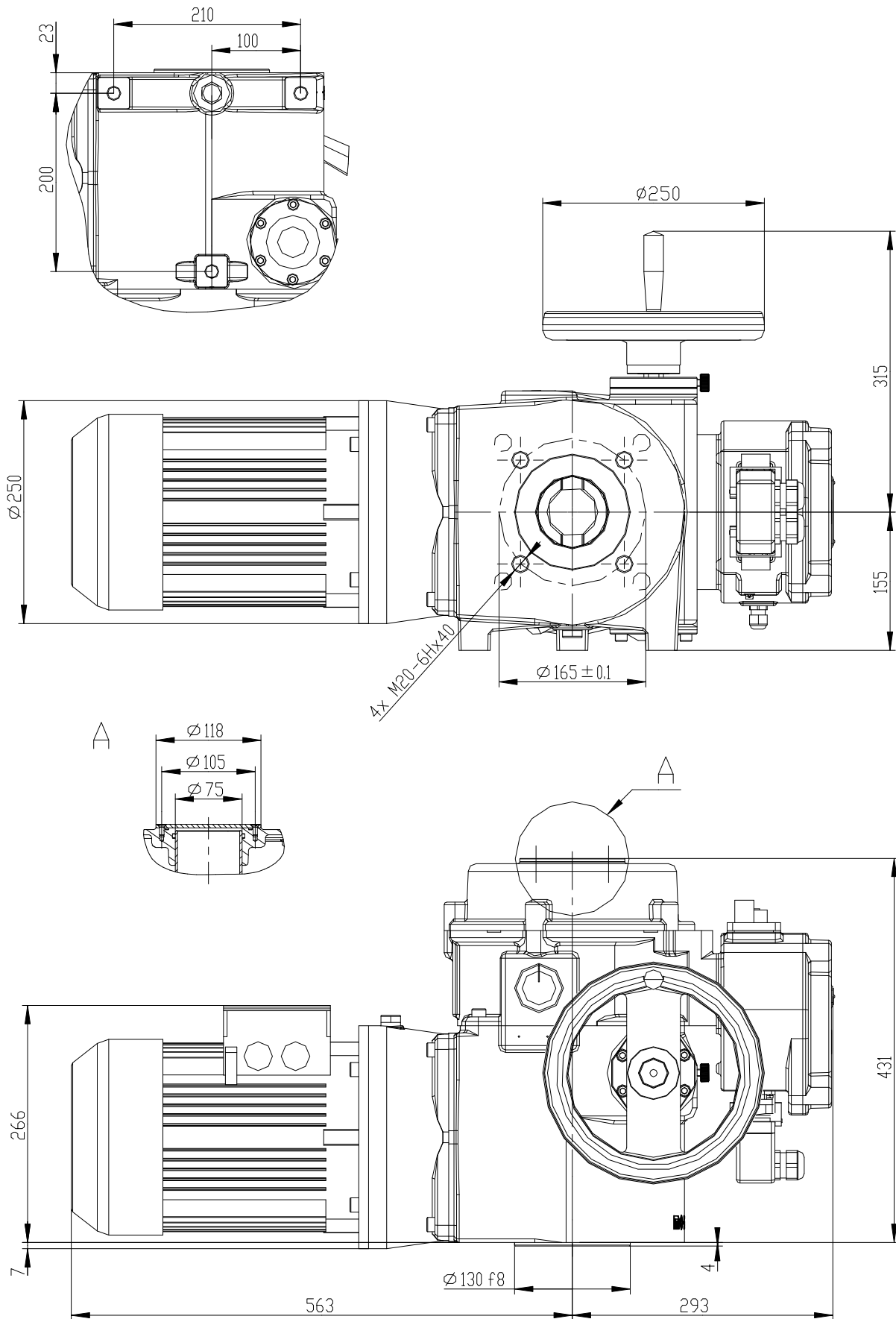

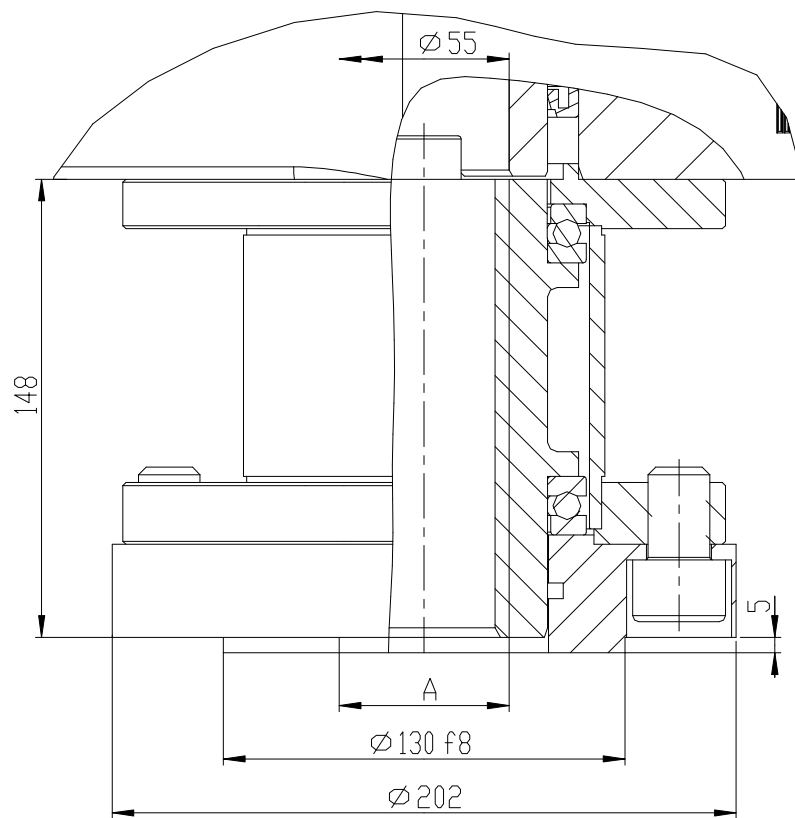
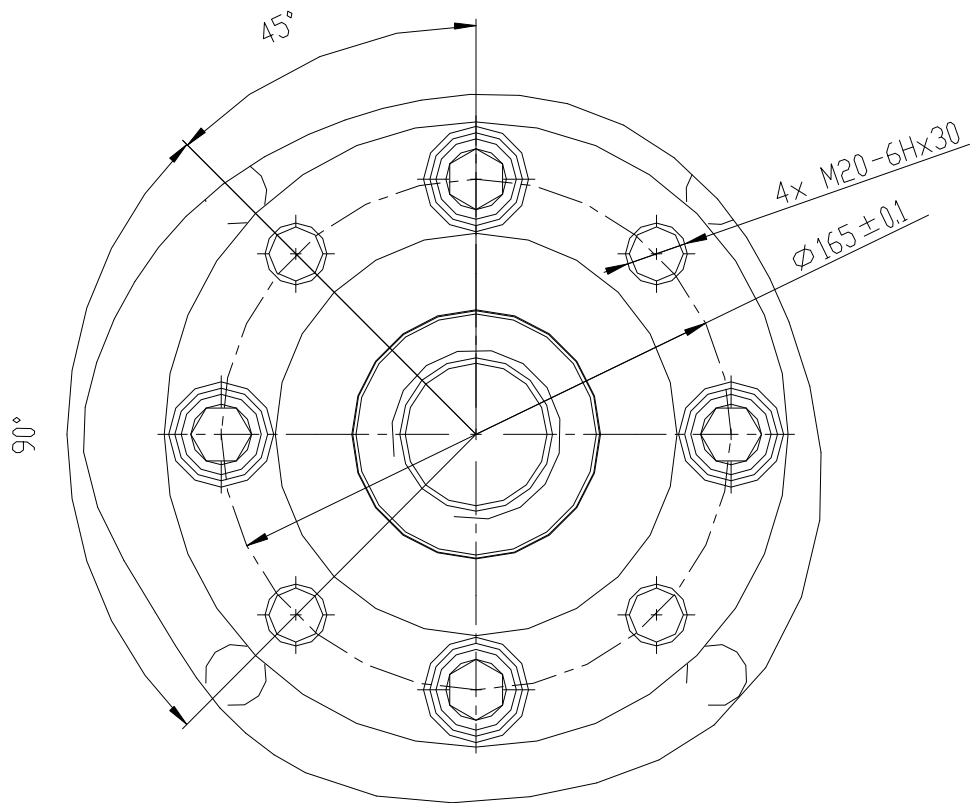

Dimension A is in table of version

P-1424/A

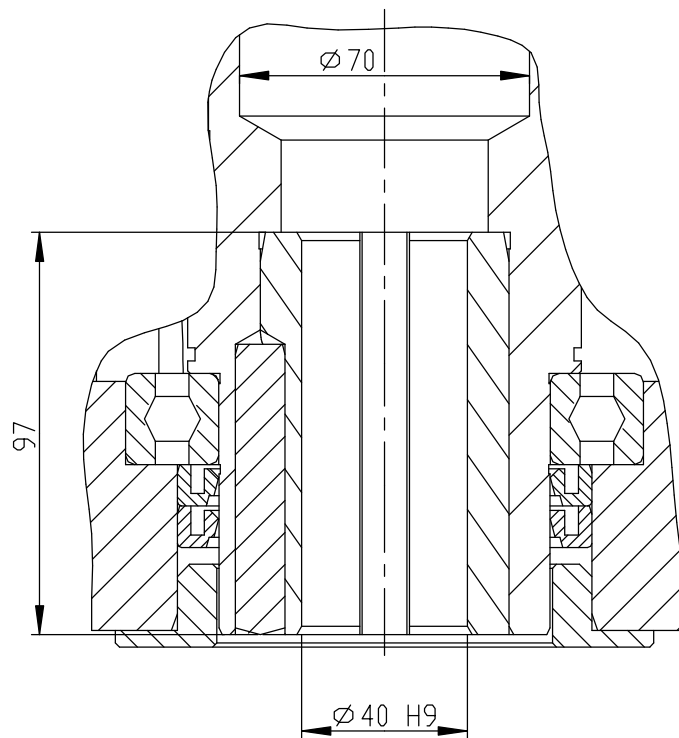
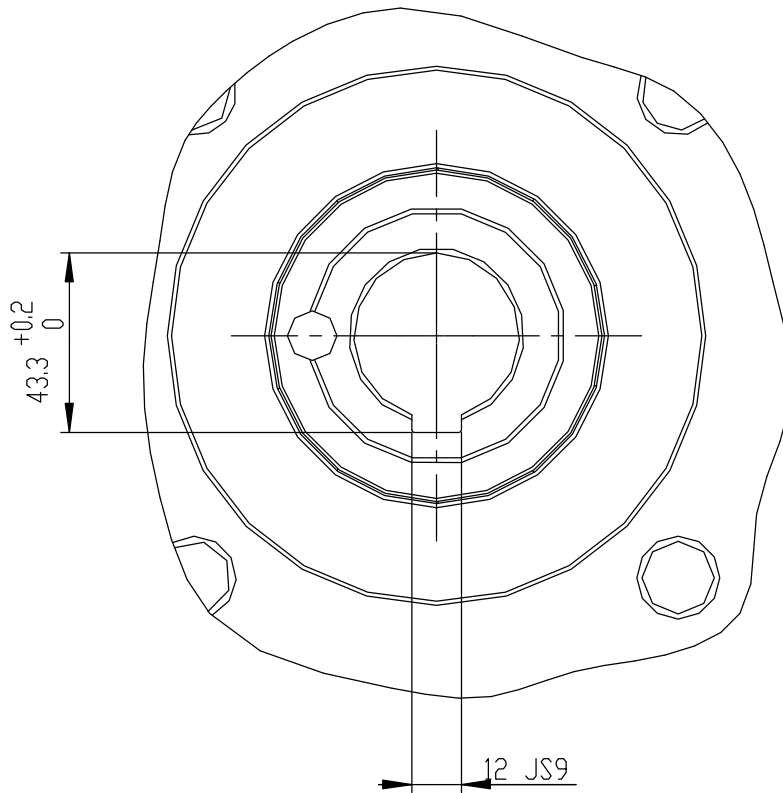

P-1424/B

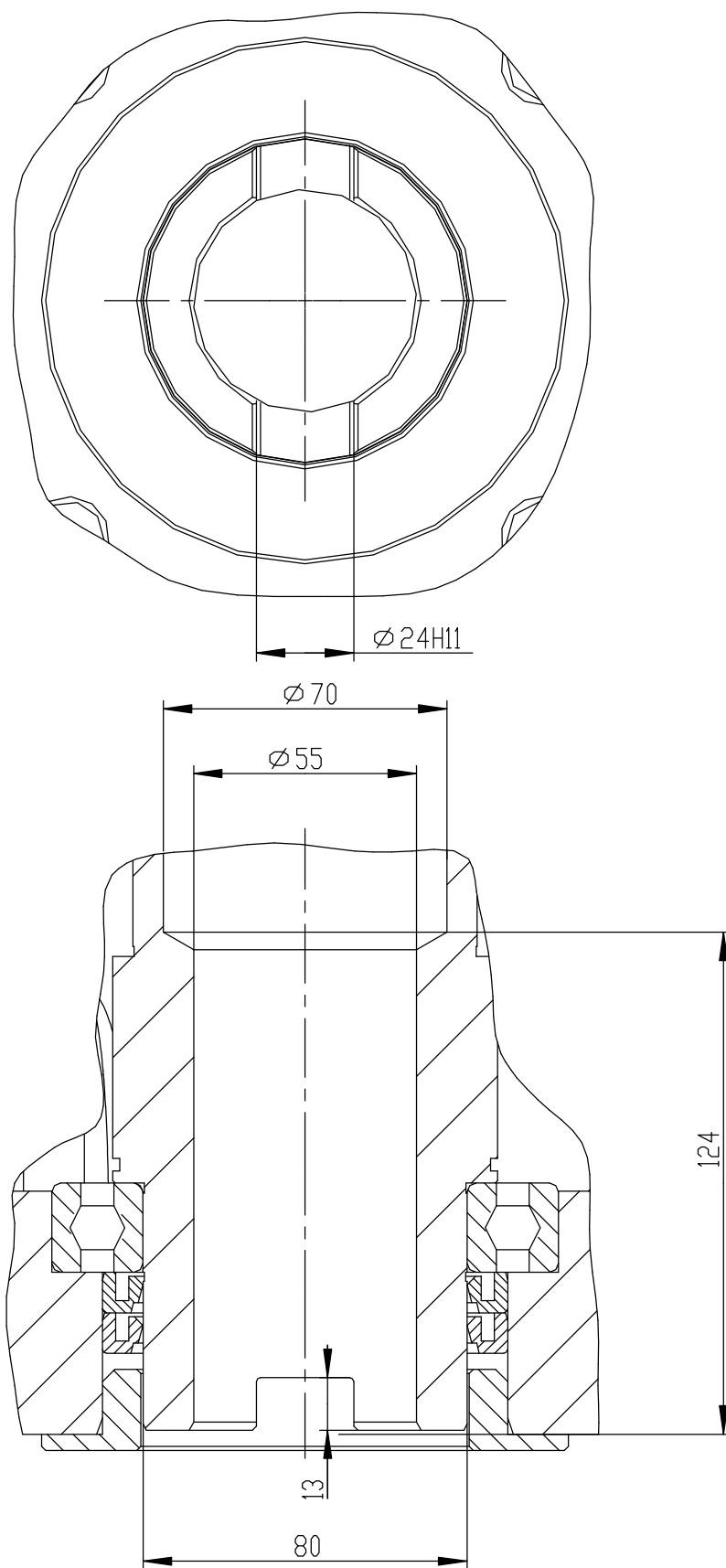

P-1424/C

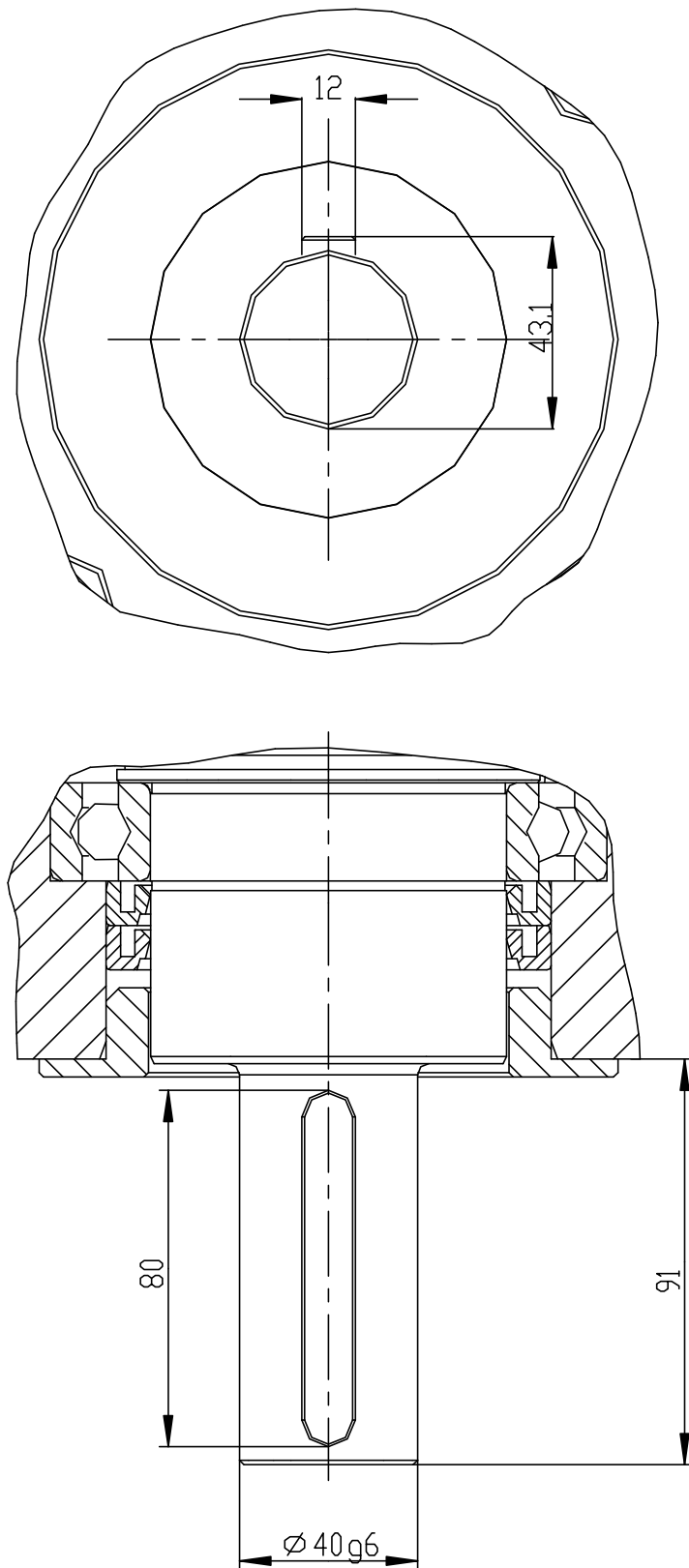

P-1424/D

Dimensional connection drawings according to GOST R 55510-2013

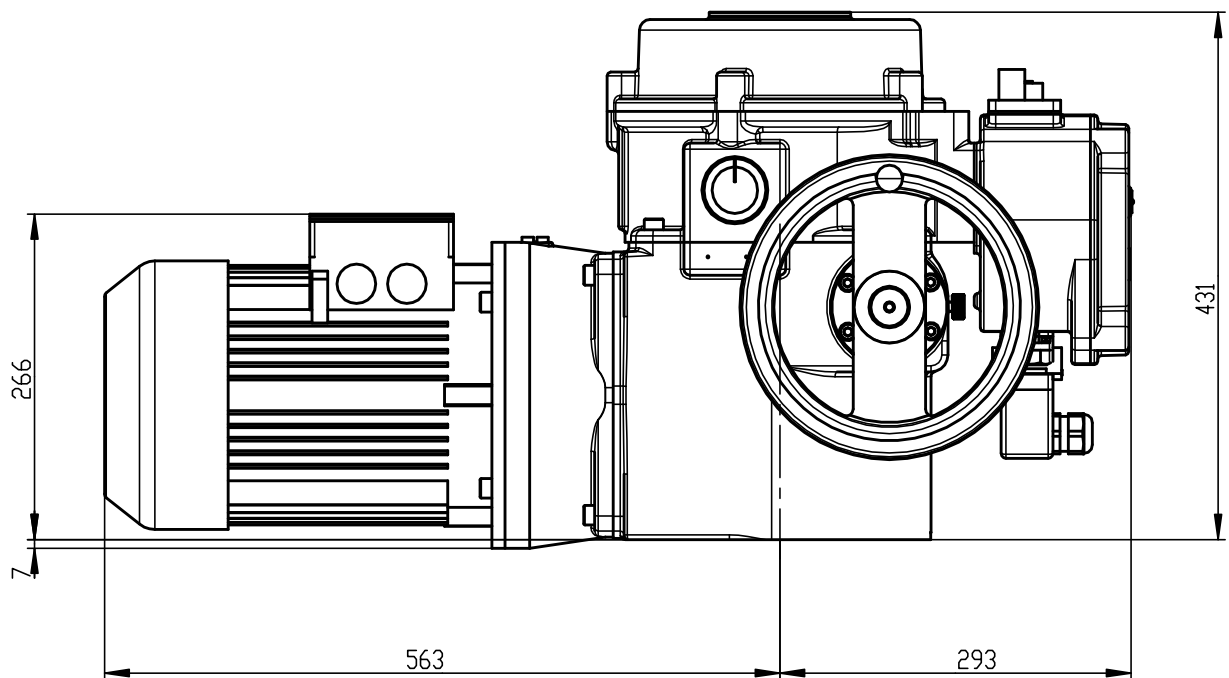
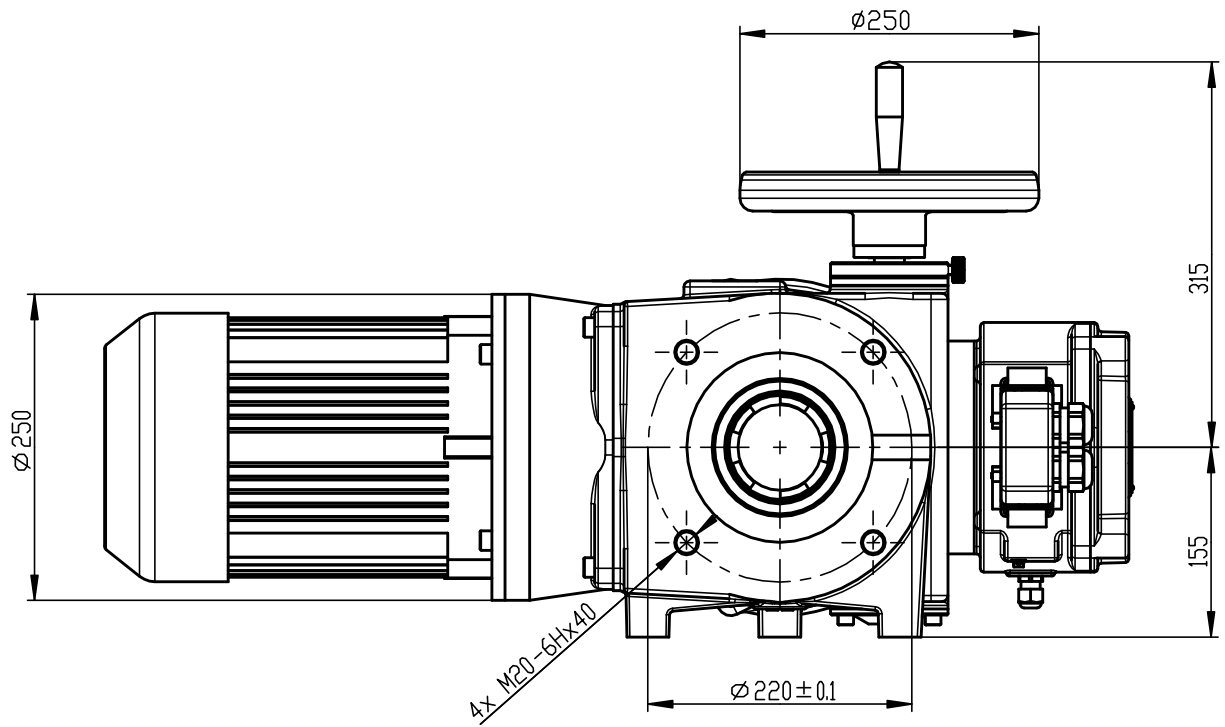

P-1425

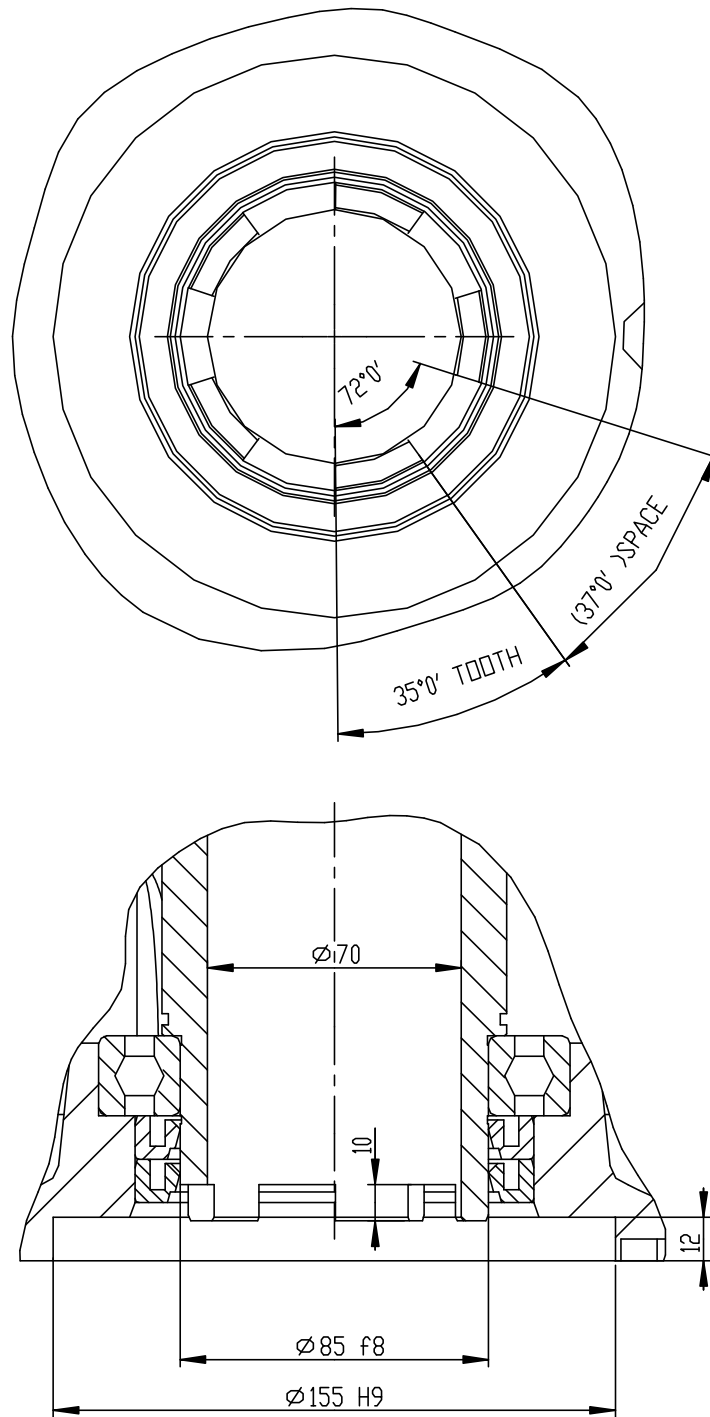

P-1425

6.3 Guarantee service check report

Service center: D	
Date of repair:	Guarantee repair no.:
User of actuator:	Claim applied by:
Actuator type number:	Actuator production number:
Product claim fault:	Detected product fault:
Used spare parts:	
Remarks:	
Issued on a day:	Signature:

6.4 Post guarantee service check report

Service center:	
Date of repair:	
User of actuator:	Actuator operating place :
Actuator type number:	Actuator production number:
Detected product fault:	
Used spare parts:	
Remarks:	
Issued on a day:	Signature:

6.5 Commercial representation

Slovak Republic:

Regada, s.r.o.,
Strojnícka 7,
080 01 Prešov
Tel.: +421 (0)51 7480 460,
Fax: +421 (0)51 7732 096,
E-mail: regada@regada.sk

Czech republic:

REGADA Česká s.r.o. (Ltd.) – exclusive representation REGADA, s.r.o. (Ltd.) for sale of electric actuators

Regada Česká, s.r.o.
Kopaninská 109
252 25 Ořech
PRAHA – západ
Tel.: +420 257 961 302
Fax: +420 257 961 301