



CE 1026

# ***INSTALLATION, SERVICE AND MAINTENANCE INSTRUCTIONS***



***Explosion-proof electric multi - turn actuators  
SO 2-Ex***

## TEST CERTIFICATE

### EXPLOSION-PROOF ELECTRIC PART-TURN ACTUATOR SO 2-Ex

Type number ..... Power supply .....V .....Hz

Serial number ..... Switch-off torque..... Nm

Production year ..... Operating speed ..... min<sup>-1</sup>

Wiring diagram ..... Adjusted number of revolutions.....

Warranty period ..... months Transmitter.....

Serial number of electric motor .....

Serial number of transmitter .....

Serial number of controller .....

Explosion-proof version:  $\text{Ex}$  II 2 G Ex db eb h IIB T5 Gb and  $\text{Ex}$  II 2 D Ex h tb IIIC T100°C Db

Final report No.: FTZÚ 03 ATEX 0272X

Design and type tests are in accordance with the following standards:

EN 60 079-0 – Electrical apparatus for explosive gas atmospheres – Part 0: **General requirement**

EN 60 079-1 – Electrical apparatus for explosive gas atmospheres – Part 1: **Flameproof enclosures “d”**

EN 60 079-7 – Explosive atmospheres Part 7: **Equipment protection by increased safety “e”**

EN/IEC 60 079-31: Explosive atmospheres – Part 31: **Equipment dust ignition protection by enclosure „t”.**

Tests made in accordance with TP 74 0742 00

Tests made by .....

Date ..... Signature and stamp .....

## COMPLETENESS CERTIFICATE

Used valve .....

Assembled by: Firm .....

Name .....

Warranty period ..... months

Date ..... Signature and stamp .....

## INSTALLATION CERTIFICATE

Location .....

Installed by: Firm .....

Name .....

Warranty period ..... months

Date ..... Signature and stamp .....

Please read these instructions carefully before mounting and operating the actuator !

## Contents

1. General Information.....	2
1.1 Purpose and Application .....	2
1.2 Safety Instructions .....	2
1.3 Product influence to environment.....	2
1.4 Data specified on electric actuator .....	3
1.5 Instructions for staff training .....	4
1.6 Warranty Conditions.....	5
1.7 Under-Guaranty and After-Guaranty Service.....	5
1.8 Operation Conditions.....	6
1.8.1 Location of the Products and Operation Position.....	6
1.8.2 Operation Environment .....	6
1.8.3 Power Supply and Operation Modes .....	7
1.9 Packaging, Transport, Storing and Unpacking.....	8
1.10 Appreciation of the product and packing.....	8
2. Description, Functioning and Specifications.....	9
2.1 Descriptions and Functioning .....	9
2.2 Specifications .....	10
2.2.1 Mechanical connection:.....	14
2.2.2 Electric connection .....	14
3. Installation and Dismantling of the Actuator .....	14
3.1 Installation .....	14
3.1.1 Mechanical Connection for Flanged Version .....	14
3.1.2 Electric Connection with Mains or Checking of Functions .....	15
3.2 Dismantling.....	16
4. Adjustment.....	17
4.1 Adjustment of the Torque Unit.....	17
4.2 Adjustment of position-signalling unit (Fig.3) .....	17
4.3 Adjustment of resistant transmitter (Fig.4) .....	20
4.4 Adjustment of the Electronic Position Transmitter (EPV) - the Resistive Transmitter (Potentiometer) with the Converter PTK 1 .....	21
4.5 Adjustment of Capacitive Transmitter CPT1/A.....	22
4.6 Adjustment of position controller (Fig. 9).....	24
4.6.1 Setting of controller .....	24
4.6.2 Watching operation and error states .....	25
5. Service and Maintenance .....	26
5.1 Service.....	26
5.2 Maintenance – Its Scope and Periodicity .....	26
5.3 Maintenance to assure inexplosiveness .....	27
5.4 Troubleshooting.....	28
6. Accessories and Spare Parts .....	28
7. Enclosures .....	29
7.1 Wiring diagrams SO 2-Ex.....	29
7.2 Wiring diagrams SO 2-Ex with controller .....	30
7.3 Dimensional drawings .....	33
7.4 Guarantee service check report.....	40
7.5 Post guarantee service check report.....	41
7.6 Commercial representation .....	42

The Installation, Service and Maintenance Instructions are drawn up according to requirements of EC Executive Nr. 2006/42/EC "Uniform requirements for machines and devices from the point of view of safety and health care", to save life and health of users and to avoid material damages and exposure environment to danger.

## 1. General Information

### 1.1 Purpose and Application

Explosion-proof electric multi-turn actuators (hereafter referred to as **EA**), types **SO 2-EX respectively SO with controller** are high performance electro-mechanical products, designed for direct assembly on controlled devices. EA of SO 2-Ex types are provided for remote control of closing bodies, and EA of SO 2-Ex with controller for automotive control of regulating bodies. They are equipped by measuring and technological processes controlling means; the information carrier on their input and/or output is unified analogue direct current, or voltage signal. They can be used in heating, energy, gas, air-conditioning and other technological equipments, for which are suitable due to their manufacturing qualities. They are assembled by means of flange and connecting component in accordance with ISO 5210, resp. DIN 3338, resp. GOST R 55510.



1. It is forbidden to use the EA as a lifting mechanism!
2. Switching of actuator by a semiconductor components/switches have to be consulted with producer.

### 1.2 Safety Instructions

#### Product characteristics from risk point of view

EA are reserved technical devices with higher rate of danger (group A), with possibility of installation in areas specially danger regarding casualties caused by electric current. EA are according to directive LVD 2014/35/EU and standard EN/IEC 61010-1, in the edition in terms of valid certificate, assigned for installation category II (overvoltage category), pollution degree 2.

### 1.3 Product influence to environment

**Electromagnetic compatibility (EMC):** the product complies with the requirements of the Directive 2014/30/EU of the European Parliament and of the Council on the approximation of the laws the Member States relating to the electromagnetic compatibility and with the requirements of EN standards as well EN/IEC 61000-6-4+A1, EN/IEC 61000-6-2, EN/IEC 61000-3-2 and EN/IEC 61000-3-3 within valid edition.

**Vibrations caused by the product:** product influence is negligible.

**Noise produced by the product:** The maximum allowable noise level (A) of the product measured in a place of operation is 80dB (A).

Electric actuators are made in explosion-proof version  $\text{Ex} \text{ II 2 GEx db eb h II B T5 Gb}$  and  $\text{Ex} \text{ II 2 D Ex h tb IIIC T100°C Db}$ , pursuant to:

EN/IEC 60079-0: Explosive atmospheres – Part 0 : Equipment general requirements – General requirements

EN/IEC 60079-1: Explosive atmospheres – Part 1 : Equipment protection by flameproof enclosures "d"

EN/IEC 60079-7: Explosive atmospheres - Part 7: Equipment protection by increased safety "e".

EN/IEC 60079-31: Explosive atmospheres – Part 31: Equipment dust ignition protection by enclosure „t“, within valid edition.

Electric parts EA are proposed:

- as devices of the group **II resp. III** for others threatened areas (excluding mines)
- of the category **2** with demanding requirements for safety
- for use max. in zone 1, 2, 21 a 22.
- for atmospheres **G** (gases, vapors or mists ) or **D** (combustible conductive dusts)
- topressure range from 0.8 to 1.1 bar.

Design version is :

- flameproof enclosures "**db**", increased safety "**eb**" or level dust ignition protection by enclosure "**tb**"
- with explosion protection group **IIB** or **IIIC**
- and temperature class **T5** (max. permissible surface temperature +100°C.

Zones for installation of explosion-proof electric actuators and conditions for equipment installation are defined in the following standards:

EN/IEC 60079-10: Electrical apparatus for explosive gas atmospheres  
Part 10: Classification of hazardous areas

EN/IEC 60079-14: Electrical apparatus for explosive gas atmospheres  
Part 14: Electrical installations in hazardous areas

Non-electric parts of electric actuators are designed, engineered, manufactured, tested and identified in compliance with the requirements for safety of machinery according to the following standards:

- EN 1127-1: Explosive atmospheres – Explosion prevention and protection  
Part 1: Basic concepts and methodology
- EN ISO 80079-36 Explosive atmospheres — Part 36: Non-electrical equipment for explosive atmospheres — Basic method and requirements
- EN ISO 80079-37: Explosive atmospheres — Part 37: Non-electrical equipment for explosive atmospheres — Non-electrical type of protection constructional safety "c", control of ignition sources "b", liquid immersion "k".

**Equipment identification** consists of the following characters:

- Ex** - electric equipment complies with standard EN/IEC 60 079-0. and related standards for the corresponding types of explosion protection.
- db** - identification of the explosion protection type - "flameproof enclosure" according to EN/IEC 60 079-1.
- eb** - identification of the explosion **protection type** – „increased safety" according to EN/IEC 60 079-7.
- tb** - identification of dust ignition protection by enclosure „t" according to EN/IEC 60 079-31.
- II or III** - identification of the class of non-explosive electric device according to the standard EN/IEC 60 079-0.
- B or C** - identification of the **sub-class II** or III of non-explosive electric devices according to the standard EN/IEC 60 079-0.
- T5 or T100°C** - identification of the **temperature class** of non-explosive electric device class II or III according to the EN/IEC 60 079-0.
- Gb** - (EPL Gb) - identification of the equipment designated for explosive gaseous atmospheres, with "high" level of protection, which is not a source of initiation in standard operation or in case of expected failures.
- Db** - (EPL Db) - identification of the equipment designated for explosive dust atmospheres, having a "high" level of protection, which is not a source of ignition in normal operation or during expected malfunctions.

**Warning for safe utilization**

**Protection of the Product**

EA SO 2-Ex and SO 2-Ex with controller has no own protection against short circuit. That is why the power supply has to contain a suitable protection device (a breaker or a fuse) that can also serve as a main switch. For protection, we recommend to use a fuse type "T" or a contactor type "C".

**Type of equipment from a connection point of view:** The equipment is designed for permanent connection.

**1.4 Data specified on electric actuator**

Type plate:

Warning plate:

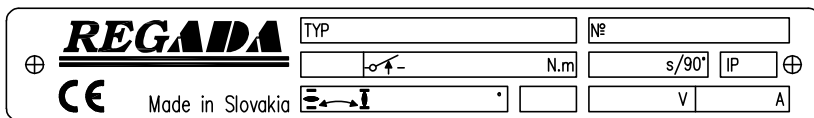

Type plate contains the basic data concerning identification, performance and electricity: indication of producer, type, serial number, max. load torque and switching-off torque, protection code, operating stroke, revolutions, supply voltage and current.

**Warning label:**

- with identification of the waiting time and requirements for strength of screws.

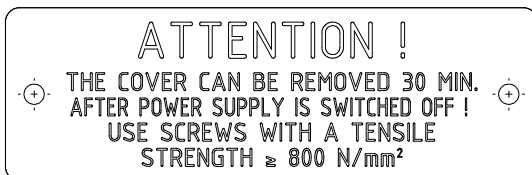



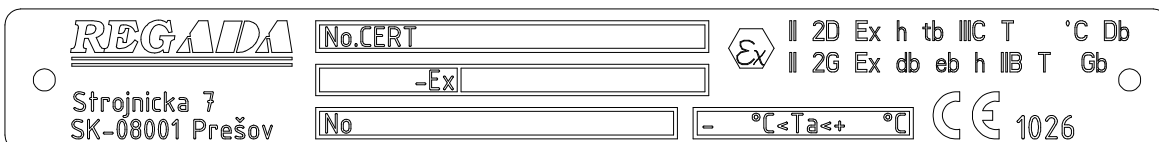

**Non-explosive label:** identifying the manufacturer, certificate number, type identification, version identification, serial number and version for ambient temperature: from -25°C up to +55°C or from -50°C up to +40°C or –from 50°C up to +55°C or from -60°C up to +55°C.



## Graphic symbols on electric actuator

The graphic symbols used on electric actuator substitute the text messages. Some of them are in accordance with EN ISO 7010, ISO 7000 and IEC 60417 within valid edition.

	Dangerous voltage	(EN ISO 7010-W012)
	Stroke of the electric part-turn actuator	
	Switching-off torque	
	Manual control	(0096 ISO 7000)
	Protection terminal	(5019 IEC 60417)

## Terminology

**Potentially explosive environment** - an environment where explosive atmosphere can occur.

**Explosive gas atmosphere** - a mixture of flammable substances (in form of gases, vapors or mist) with air under atmospheric conditions, which upon initiation enables the propagation of the combustion in unconsumed mixture.

**Maximum surface temperature** - maximum temperature occurring during operation in most adverse conditions (but within accepted tolerance limits) at any part of the surface of the electric device, that could result in ignition of the surrounding atmosphere.

**Enclosure** - all walls, doors, covers, cable glands, shafts, rods, draw bars, etc., that contribute to the level of protection against explosion or to the level of protection (IP) of the electric device.

**Flameproof enclosure " db "** - type of protection wherein the parts capable of igniting an explosive atmosphere are located within the enclosure, in case of explosion of an explosive mixture within the enclosure, such enclosure will withstand the pressure of the explosion and prevent the propagation of explosion to the surrounding atmosphere.

**Increased safety " eb "** - type of protection applied to electrical apparatus in which additional measures are applied so as to give increased security against the possibility of excessive temperatures and of the occurrence of arcs and sparks in normal service or under specified abnormal conditions.

**Dust ignition protection by enclosure " tb "** - type of protection for explosive dust atmospheres where electrical equipment is provided with an enclosure providing dust ingress protection and a means to limit surface temperatures.

**Combustible dust** - finely divided solid particles, 500 µm or less in nominal size, which may be suspended in air, may settle out of the atmosphere under their own weight, may burn or glow in air, and may form explosive mixtures with air at atmospheric pressure and normal temperatures.

**Conductive dust** - combustible dust with electrical resistivity equal to or less than  $10^3 \Omega \cdot m$ .

**Combustible flyings** - solid particles, including fibres, greater than 500 µm in nominal size which may be suspended in air and could settle out of the atmosphere under their own weight.

## 1.5 Instructions for staff training

### Requirements for specialized skills of persons performing assembly, operation and maintenance



The electrical connection of the actuator can only be carried out by a person in accordance with legislative requirements of the given country, depending on the required areas of location/use. Service can be performed only by workers professionally qualified and trained by the producer or contracted service centre.

## Warning for safety use



1. Products are assigned for operation in environment consist of gas, steam and vapours, with temperature range from  $-25^{\circ}\text{C}$  up to  $+55^{\circ}\text{C}$ ; and special version for ultra low temperatures from  $-50^{\circ}\text{C}$  up to  $+40^{\circ}\text{C}$ , from  $-50^{\circ}\text{C}$  up to  $+55^{\circ}\text{C}$  or from  $-60^{\circ}\text{C}$  up to  $+55^{\circ}\text{C}$ , to pressure range from 0.8 to 1.1 bar. EA can be installed at areas specified as zone 1, 2, 21 a 22.

It matters about following products:

- group **II or III**
  - for type of the environment **G or D**
  - the category **2**
  - subgroup **B and C**
  - temperature class **T5**.
2. Products are designed according to standards for electrical and non-electrical devices assigned for areas with danger of explosion:
    - for electric parts: EN/IEC 60079-0, EN/IEC 60079-1 and EN/IEC 60079-7 and EN/IEC 60079-31.
    - for non-electric parts: EN 1127-1, EN ISO 80079-36 and EN ISO 80079-37.
  3. The maximum surface temperature of the actuator for given group **T5** is not allowed to exceed  $+100^{\circ}\text{C}$ .
  4. If the actuator is placed on device which regulate medium with higher temperature than  $+55^{\circ}\text{C}$ , protect the actuator by additional construction in order to maintain ambient temperature max.  $+55^{\circ}\text{C}$  and also to stop temperature transmitting through junction component!
  5. Cable glands blinds are assigned only for transport and storage period, i.e. for period till the actuator is builded into operation with danger of explosion, than blinds must be replace by connecting cable.
  6. If any of the cable glands are not used to install a cable, it must be replaced with certified Ex plug of the approved type.
  7. CAUTION !: The cover can be removed 30 minutes after power supply is switched off! Use screws with a tensile strength of  $\geq 800 \text{ N/mm}^2$ .
  8. WARNING – Potential electrostatic charging hazard.  
During operation of EA it must be prevented any process with intensive formation of electrostatic charge stronger than manual friction of his surface.

### 1.6 Warranty Conditions

The supplier is responsible for the completeness of the delivery and warrants the parameters of the products that are stated by the technical conditions (TC) or the parameters agreed in the agreement.

The supplier is not responsible for decline of quality caused by the purchaser while storing, unprofessional installation or incorrect operation.

### 1.7 Under-Guaranty and After-Guaranty Service

All our products can be serviced by the professional service staff of our firm that provides installation, operation, service, checking and troubleshooting.

**The under-guaranty service** is provided by the service department of the producer on the basis of a written claim.

While claiming it is advised to present the following:

- basic data from the nameplate (type and serial numbers)
- period in operation, ambient conditions (temperature, humidity,...) operation mode including switching frequency, type of switching (position or thrust), adjusted switching thrust).
- a kind of failure - a description of the claimed failure
- a copy or a transcription of Installation Certificate.

It is advised to perform the **after-guaranty service** by the service department of the producer or by a contracted service firm.

## 1.8 Operation Conditions

### 1.8.1 Location of the Products and Operation Position

The EA can be built-in and operated in the sheltered places of industrial objects without any temperature or humidity control and with a protection against direct climate exposure (e.g. direct sunshine), except the special version designed for waste water treatment plants, water management, the selected chemical plants and tropic conditions.



#### Warning:

When the EA is installed in open air, **it must be** sheltered lightly to protect is against direct effects of atmosphere.

When installed in the areas with relative humidity more than 80%, in open air under a shelter it is needed to connect the space heater directly – without a thermal switch.

EA can be built-in and operated in any position. Standard position is with vertical axis of the output part and with the control part placed above.

### 1.8.2 Operation Environment

According to valid standard IEC 60 721-2-1, there are delivered these versions of electric actuators:

1) Version „temperate“ for type climate temperate

In accordance with IEC 60 364-1, IEC 60 364-5-51 and IEC 60 364-5-55 within valid edition the EA have to resist external effects and operate reliably:

**In the conditions of the following types of environment:**

- warm mild to very hot dry with temperatures  $-25^{\circ}\text{C}$  to  $+55^{\circ}\text{C}$  ..... AA 7\*
- in 1kg of dry air , with temperatures stated above ..... AB 7\*
- with elevation up to 2000 m, with barometric pressure range from 86 kPa up to 108 kPa ..... AC 1\*
- with shallow dive – (product in protection IP x 7) .....AD 7\*
- with strong dustiness – with a possibility of influences of inflammable, non-conducted and non-explosive dust; the middle layer of dust; the dust drop more than 350 but not more than 1000  $\text{mg}/\text{m}^2$  per day (products with protection enclosure of IP 6x) ..... AE 6\*
- with occasional or casual appearance of corroding and polluting substances (occasional or casual
- expose to corroding or pollute chemical substances during producing or using of these substances); at places where is handled with small quantity of chemical products and these can accidentally get in contact with an electric device .....AF 3\*
- with a possibility of influences of mechanical stress:
  - medium sinusoid vibrations with frequency in range 10 up to 150 Hz, with shift amplitude of 0,15 mm for  $f < f_p$  and acceleration amplitude  $19,6 \text{ m}/\text{s}^2$  for  $f > f_p$ ; (transition frequency  $f_p$  is from 57 up to 62 Hz) .....AH 2\*
  - medium impacts, shocks and vibrations .....AG 2\*
- with serious danger of plants and mould growing .....AK 2\*
- with serious danger of animal occurrence (insects, birds, small animals) .....AL 2\*

with detrimental influence of radiation:

- of stray current with intensity of magnetic field (direct or alternate, of mains frequency) up to  $400\text{A}\cdot\text{m}^{-1}$  .....AM2\*
- of sun radiation with intensity  $> 500$  and  $\leq 700\text{W}/\text{m}^2$  ..... AN 2\*
- with effects of medium seismic activity with acceleration  $> 300 \text{ Gal}$   $\leq 600 \text{ Gal}$  .....AP 3\*
- with indirect endanger by storm .....AQ 2\*
- with quick air movement and strong wind .....AR 3 , AS 3\*
- stand on a conductive bottom) ..... BC 3\*
- with a danger of inflammable gases and vapours explosion - for Ex of version ..... BE 3N2\*
- fire risks ..... BE 2\*

\* Marking in accordance with IEC 60364-1, IEC 60 364-5-51 and IEC 60 364-5-55 within valid edition



### 1.8.3 Power Supply and Operation Modes

#### Power supply:

Electric motor.....	230/220 V AC $\pm 10\%$ , 3x400/3x380 V AC $\pm 10\%$ , resp. 24 V AC /DC $\pm 10\%$
Control part.....	230 $\pm 10\%$ resp. 24 V AC /DC $\pm 10\%$
potentiometer transmitter .....	max. $\sqrt{P \times R}$ V DC/AC
electronic positional transmitter (EPV) without power supply .....	15 up to 30 V DC, or 24 V DC
capacitive transmitter without power supply .....	18 up to 28 V DC

**Frequency of power supply** ..... 50 resp. 60\*\* Hz  $\pm 2\%$

\*\* Stroke speed will increase 1,2 times, and torque will decrease 1,2 times

**Duty cycles** (according to EN 60304 within valid edition):

**EA SO 2-Ex are designed for *remote control*:**

- with short operation S2-10min
- with interrupted operation S4-25%, max. 90 cycles/hour

**EA SO 2-Ex controllers are designed for *automotive control***

- with interrupted operation S4-25%, 90 to 1200 cycles/hour

Note: 1. The duty cycles consists of the kind of load, the loader and the frequency of switching.

2. Once EA SO 2-Ex is connected to the external controller unit, also use it as a control EA where the maximum load torque reaches the 0.8 multiple of the maximum loading torque for remote operated EA SO2.

## 1.9 Packaging, Transport, Storing and Unpacking

Surfaces without surface treatment are treated by conservation preparation MOGUL LV 2-3 before packaging .

Conservation is not necessary if the following storage conditions are complied with:

- Storage temperature: -10 to +50 °C
- Relative air humidity max.80 %
- Electric actuators and their accessories must be stored in dry, well ventilated covered spaces, protected against impurities, dust, soil humidity (by placement to racks, or on palletes), chemicals and foreign interventions
- There shall be no corrosive gases present in the storage areas.

The **EA SO 2-Ex** are delivered in solid packages, assuring the resistance according to the requirements of standards EN/IEC 60654.

The package is made by a box. The products in the boxes can be packed on pallets (the pallet is returnable).

The following information is given on the outside of the package:

- the producer
- the name and the type of the product
- number of pieces
- other data – inscriptions and labels.

The forwarder is obliged to protect the packed products loaded into transport means against spontaneous motion, in case of an open transport mean they are to be protected against rainfalls and flowing water. Location and fixing of the products in transport means should guarantee their fixed position, avoid possibility of mutual bumps and bumps against the walls of the transport means.

The transport in non-heated and non-pressurized transport means with conditions in range:

- temperature: -25°C to +70°C (special versions –50°C to +45°C)
- humidity: 5 to 100% with maximum water content of 0.028 kg/kg of dry air
- barometric pressure: 86 to 108 kPa .

**After receiving of the EA check whether during their transport or storing no damage occurred.**

**Compare the data on their nameplates with the accompanying documentation/the purchase agreement (the order). In case of any discrepancy, failure or damage inform about the fact the producer immediately.**



*If not installed immediately the EA and their equipment should be stored in dry, well-conditioned sheltered areas, protected against impurities, dust and soil humidity (with keeping them on shelves or pallets), chemical and unauthorized impacts, at ambient temperature from -10°C to +50°C and at relative air humidity max. 80 %, in special version at temperature –50°C do +40°C.*

- It is forbidden to store EA outside or in areas not prevented against direct impact of climate.
- Strains of the surface finishing should be promptly removed if any – it can prevent the product against corrosion damages.
- While storing more than one year it is necessary to check lubrication filling before the actuator is put into operation.
- The EA installed but not operated are to be protected the same way as when storing (e.g. with a wrapping).
- After it is mounted onto a valve in free and wet areas or in areas where temperature is changing it is necessary to connect the space heater – to prevent the actuator against corrosion resulted from water condensed in the control part.
- Remove odd conservation grease as late as before putting into operation.

## 1.10 Appreciation of the product and packing

The product is made of recyclable. The single parts of the package and the product should not be thrown away after its lifetime but sorted according to the related regulations and rules about environment protection and delivered for next treatment.

The product itself as well as its package is not a source of spoiling of environment and they do not contain any dangerous waste.

## 2. Description, Functioning and Specifications

### 2.1 Descriptions and Functioning

The EA **SO 2-Ex** are of the compact design with several connected modules. They consist of two functionally different main parts.

**The gear part** is made of flange with a coupling for connection with the controlled part and gearsings placed in the bottom case; on the opposed side there are led drive mechanisms for units of the controlled part.

**The control part (Fig. 1)** is located on the control board (1), which contains:

- an electric motor (2) (for the single-phase version it is with a capacitor )
- a torque unit (5) – controlled by axial motion of a worm gear
- a position-signalling unit (3) with a position transmitter (6) - resistive, capacitive or an electronic position transmitter (6)
- a space heater with (8) with thermal switch.
- electric connection is realised using **terminal boards** (10) (located in the control area) and cable bushings, or **connector** with cable bushings

#### **Additional accessories:**

**Manual control:** made up by a handwheel with a worm gearing

**Local electric control module** (Fig.12)

The **SOR 2** version is equipped with an **electronic controller** (9). The position controller allows automatic position adjustment of the EA output part depending upon the input signal value and provides also additional functions.

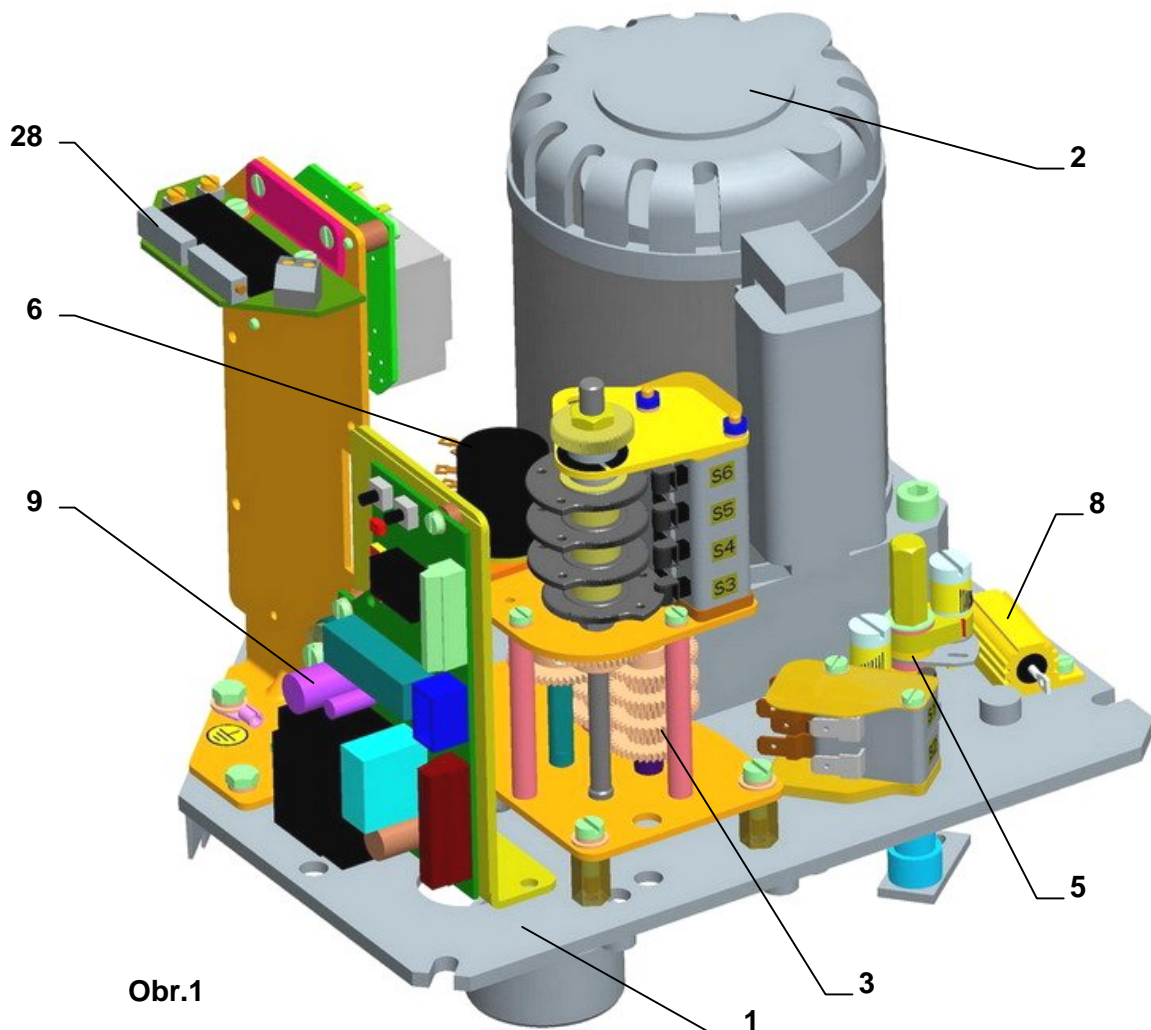

## 2.2 Specifications

Basic Specifications are given in the table 1.

**Table 1: Basic Specifications**

Type/ type number	Operation speed ±10[%]	Number of revolutions	Maximum load torque	Switching torque ±10 [%]	Weight	Electric motor <sup>1)</sup>					
						Supply voltage	Nominal			Capacitor capacity	
							Power output	Speed	Curren t		
[rev/min]	[rev]	[Nm]	[Nm]	[kg]	[V]	[W]	[1/min]	[A]	[μF/V]		
1	2	3	5	6	7	8	9	10	11	12	13
SO 2-Ex	40	3,125 - 320	10	7,5 - 12	16,0 - 20,0	Single-phase	230/220	60	2750	0,7	7/400
	20		22	15 - 25							
	12,5		34	24 - 40							
	10		42	30 - 50							
	40		10	7,5 - 12		Single-phase/ direct current- voltage	24	65	2800	7,0	-
	20		22	15 - 25							
	12,5		34	24 - 40							
	10		42	30 - 50							
SO 2-Ex with controller type No. 042	40	3,125 - 320	8	7,5 - 12	16,0 - 20,0	Single-phase	230/220	60	2750	0,7	7/400
	20		17	15 - 25							
	12,5		27	24 - 40							
	10		68	30 - 50							
	40		8	7,5 - 12		Single-phase/ direct current- voltage	24	65	2800	7,0	-
	20		17	15 - 25							
	12,5		27	24 - 40							
	10		34	30 - 50							

1) Switching elements for different type of load (also for EA) defines standard EN 60 947-4-1.

**Other specifications:**

**Protection enclosure of EA:**..... IP 66/IP 67 (EN 60 529 within valid edition)

**Mechanical ruggedness**

sinusoid vibrations with frequency of 10 to 150 Hz ..... with shift amplitude of 0,15 mm for  $f < f_p$   
 .....with acceleration amplitude of  $19,6 \text{ m/s}^2$  for  $f > f_p$   
 ..... (transition frequency  $f_p$  should be in range 57 to 62 Hz)

**Resistance by drops**.....300 drops with acceleration of  $5 \text{ m.s}^{-2}$

**Self-locking:** ..... the EA is not self-locked

**Protection of the motor** .....by the thermal switch

**Brakes of the EA:** ..... electro-magnetic brakes

**Clearance of the output part:** ..... max.5° at 5% load of the switching-off torque

**Electric control:**

- remote control (the output element of the EA is controlled with supply voltage) (SO 2-Ex), resp. SO 2-Ex with built-in controller - by feeding of unified signal
- Adjustment of the limit positions

Precision of limit position switches .....adjustment working stroke  $\pm 5\%$  of max. set stroke

Additional position relays adjustment .....cca 1 revolution beneath the limit switches

Hysteresis of position switches ..... max. 5% of the max. stroke of the chosen range

Failure of the customer to specify the particular operating speed parameter in more details the speed are set to the value according to the 3<sup>rd</sup> degree of the selected range – see Table 2.

**Adjustment of the torque switches:**

If other adjustment not specified the switching torque is set to the maximum value with tolerance of  $\pm 10\%$ .

**Switches – standard version D38:**

supply voltage ..... 250 V(AC); 50/60 Hz; 6(4) A;  $\cos \varphi=0,6$ , resp.: 24 V (DC); T=L/R=3ms  
min. current 100mA

**Switches – gold-plated contacts – special version D41:**

supply voltage 0,1(0,05) A, max. 250 V AC;  
0,1 – 24 V DC; T=L/R=3ms  
min. current 5mA

**Space heaters (E1)**

The space heater – supply voltage:.... according to the supply voltage of the motor (max. 250 V AC);

Heating power: ..... cca 20 W/55°C

**Thermal switches of the space heaters (F2)**

Supply voltage: ..... according to the supply voltage of the motor (max. 250 V AC, 5 A)

Temperature of switching on:  $+20^{\circ}\text{C} \pm 3\text{ K}$

Temperature of switching off:  $+30^{\circ}\text{C} \pm 4\text{ K}$

**Manual control:**

- with a handwheel after pressing the detent button. Rotate the handwheel clockwise to move the output shaft in the direction „Z“.

**Position transmitter****Resistive – potentiometer:**

Resistance (single **B1**):..... 100  $\Omega$ , 2000  $\Omega$

Resistance (double **B2**): ..... 2x100  $\Omega$ , 2x2000  $\Omega$

Operating life of transmitter .....  $10^6$  cycles

Load capacity:..... 0,5 W up to 40°C (0 W/125°C)

Maximum current of sliding contact ..... max. 35 mA

Maximum supply voltage:.....  $\sqrt{P \times R}$  V DC/AC

Potentiometer linearity error:.....  $\pm 2,5 [\%]^1$

Potentiometer hysteresis:..... max.2,5  $[\%]^1$

for **SO 2-Ex** "O" (open) .....  $\geq 93\%$ , "Z" (closed) .....  $\leq 5\%$

for **SO 2-Ex with controller** "O" (open) ...  $\geq 85\%$  and  $\leq 95\%$ ; "Z" (closed)  $\geq 3\%$  and  $\leq 7\%$

**Capacitive (B3): non-contact, life  $10^8$  cycles****2-wire connection** with power supply or without power supply

The current signal **4 ÷ 20 mA** (DC) is acquired from the capacitive transmitter supplied from the internal or an external voltage supply source. The electronics of the transmitter is protected against eventual wrong polarity and current overloading. The entire transmitter is galvanic insulated so several transmitters can be connected to one external voltage source.

Power supply voltage (with power supply) .....	24 V DC
Power supply voltage (without power supply) .....	18 to 28 V DC
Ripple voltage .....	max. 5%
Max power input .....	0,6 W
Load resistance .....	0 to 500 $\Omega$
Load resistance can be single side grounded.	
Influence of resistance on output current .....	0,02%/100 $\Omega$
Influence of voltage on output current .....	0,02%/1V
Temperature dependency .....	0.5% / 10 °C

Output signal values at limit positions: ..... "O" .... 20 mA (clamps 81,82)  
 ..... "Z" ..... 4 mA (clamps 81,82)

Values tolerance of output signal of capacitive transmitter ..... "Z" +0,2 mA  
 ..... "O"  $\pm$ 0,1 mA

**Electronic positional transmitter (EPV) - converter R/I (B3)****a) 2-wire version - without built-in power supply, or with built-in power supply**

Current signal .....	4 ÷ 20 mA (DC)
Power supply voltage (at version without build-in power supply) .....	15 ÷ 30 V DC
Power supply voltage (at version with build-in power supply) .....	24 V DC $\pm$ 1,5%
Load resistance (at version without build-in power supply) .....	max. $R_L = (U_n - 9V) / 0,02A$ [ $\Omega$ ]
(U <sub>n</sub> - power supply voltage [V])	
Output signal values at limit positions: .....	"O" .... 20 mA (clamps 81,82)
.....	"Z" ..... 4 mA (clamps 81,82)
Values tolerance of output signal of EPV .....	"Z" ..... +0,2 mA
.....	"O" ..... $\pm$ 0,1 mA

**b) 3-wire version - without built-in power supply, or with built-in power supply**

Current signal .....	0 ÷ 20 mA (DC)
Current signal .....	4 ÷ 20 mA (DC)
Current signal .....	0 ÷ 5 mA (DC)
Power supply voltage (at version without built-in power supply) .....	24 V DC $\pm$ 1,5%
Load resistance .....	max. 3 k $\Omega$

Output signal values at limit positions: ..... "O" .... 20 mA or 5 mA (clamps 81,82)  
 ..... "Z" ..... 0 mA or 4 mA (clamps 81,82)

Values tolerance of output signal of EPV and capacitive transmitter ..... "Z" +0,2 mA  
 ..... "O"  $\pm$ 0,1 mA

EPV and capacitive transmitter linearity error: .....  $\pm$ 2.5 %<sup>1)</sup>  
 EPV and capacitive transmitter hysteresis: ..... max. 2,5 %<sup>1)</sup>

<sup>1)</sup> from rated value of transmitter referred to output values

**Electronic position controller (N)****Controller software equipment:****A) Function and parameters**programmable **functions:**

- with functional buttons SW1, SW2 and LED diodes D3, D4 directly placed on controller
- with computer or terminal equipped with corresponding programme, using RS 232 interface.

programmable **parameters:**

- control signal
- response to SYS-TEST signal
- mirroring (ascending/descending characteristics)
- insensitiveness
- EA limit positions (only with computer and ZP2 programme)
- way of regulation

**B) Operation states of controller****Error message** from error memory: (using LED diodes and RS 232 and personal computer)

- control signal missing or faulty
- input value of current control signal under 3.5 mA
- existence of SYS-TEST signal
- activity of switches
- failure of feedback position transmitter

**Statistic data:** (using RS 232 and personal computer)

- number of controller operation hours
- frequency of relay switching in direction "opening"
- frequency of relay switching in direction "closing"

**Supply voltage:** ..... terminal 61 (L1) -1(N) - 230 V AC  $\pm 10\%$

**Frequency:** ..... 50/60 Hz  $\pm 2\%$

**Input control signals - analogue:** ..... 0 - 20 mA

..... 4 - 20 mA

..... 0 - 10 V

(Actuator opens at rising of control signal.)

**Controller linearity:** ..... 0.5 %

**Controller insensitiveness:** ..... 1 - 10% (adjustable)

**Feedback (position transmitter):** ..... resistive 100 up to 10,000  $\Omega$

..... current 4 up to 20 mA

**Power outputs:** ..... 2x relay 5A/250 V AC

**Digital outputs:** .....4x LED (supply, error, adjustment, "opening", "closing" - with two-color LED)

**Error status:** ..... control switch 24 V, 2W - POR

**Reaction at error situation:** ..... transmitter error - error message LED

**Control signal missing:** ..... error message LED

**SYS mode:** ..... error message LED

**Adjusters:** ..... communication connector

..... 2x calibrating and adjusting button

### 2.2.1 Mechanical connection:

- with flanges (ISO 5210, DIN 338, GOST R 55510)

Main and connecting dimensions are given in the dimensional drawings.

### 2.2.2 Electric connection

- **with terminal board (X):** max. 21 terminals - connecting cable size max. 1.5 mm<sup>2</sup>;  
2 cable bushings – M20x1,5 (øD = 9 to 13 mm )  
øD = connecting cable diameter

**With protection terminal:** external and internal, mutually connected and marked with protection earthing mark

**Electric control:** Main and connecting dimensions are given in the **dimensional drawings**.

## 3. Installation and Dismantling of the Actuator



*Follow safety regulations!*

### Note:

*Check again whether the EA is place in accordance with the Chapter “Operation Conditions”. If the installation conditions are different than recommended it is needed to consult the situation with the producer.*

Before starting the installation onto the valve:

- Check again whether the EA was not damaged while storing.
- Check compliance of the stroke adjusted by the producer and the connecting dimensions of the EA with the parameters of the valve.
- In case of any difference perform the adjustment according to the Chapter “Adjustment”.

### 3.1 Installation

The EA are adjusted by the producer to the parameters stated on the nameplate.  
Put on the handwheel before assembly.

#### 3.1.1 Mechanical Connection for Flanged Version

- Defat the abutting areas of the connecting flange of the EA valve or the gear carefully;
- Lubricate the output shaft of the valve/gear with a grease not containing any acids;
- Set the EA to the limit position “closed”, set the valve to the same position;
- Put the EA onto the valve with the output shaft reliably stalled in the valve coupling/gear;

#### **Attention! Do not adjust EA on an armature forcibly because of damage of the gear!**

- Use the hand wheel to turn the EA to fit the openings in the EA and valve flanges if needed;
- Check whether the connecting flange abuts with the valve/gear.
- Fix the flange with four screws (with mechanical strength min 8G) fixed the way the actuator can be moved. Tighten the screws equally in cross.
- At the end check the correctness of the fixture with the valve with rotating the hand wheel.



### 3.1.2 Electric Connection with Mains or Checking of Functions

Follow up with connecting the EA with mains or master system.



1. Follow instructions given in the Chapter "Requirements for Professional Qualification..."!
2. While laying electric wiring follow instructions for heavy-current appliances installations!
3. Cables should be brought to terminal boards or connectors with cable screwed bushings!
4. Before the EA is put into operation join the internal and external earthing terminals!
5. The inlet cables should be fixed onto a fixed construction max. 150 mm from the bushings!

#### Connecting with the master system:

The EA can be controlled with:

- a built-in position controller
- an external position controller



1. If the EA is controlled with an external controller using unified signal from a two-wire transmitter (capacitive or resistive with a converter in two-wire connection), it is needed to arrange connecting of the two-wire transmitter loop to electrical earth of the successive external controller!
2. Connection can be performed only in one point, in any part of loop out of the EA.
3. Electronics of the two-wire transmitters is galvanically insulated that is why it can serve as an external source for supplying of several transmitters (their number depends on current which the source can supply).

#### Connecting to terminal board

Check whether the type of current, supply voltage and frequency correspond with data on the nameplate of electric motor.

Remove the upper cover.

In case of the single-phase version the phase L1 and the lead N,, the protection cables to the marked places of internal and external protection terminals.

Connect the control cables according to the wiring diagram placed into the internal side of the cover.

Put the cover on and tighten it uniformly crosswisely.

Tighten the cable bushings firmly to assure the protection enclosure rate.

#### Notes:

1. The EA are delivered with bushings, which in case of tight putting on the leads assure protection enclosure up to IP 68. For required protection enclosure it is needed to use rings according to the actual cable diameter.
2. While fixing the cable it is needed to count with allowed bend radius to avoid damaging or deformation of the sealing element of the bushing. The leads are to be fixed with the solid construction at most 150 mm from the bushings.
3. It is recommended to use screened cables to connect remote transmitters.
4. The face areas of the control part cover have to be before re-mounting clean, coated with a grease without any acid (e.g. vaseline) and sealing not damaged to avoid joint corrosion.
5. Reversation of the EA is sure, if the period between switching-off and switching-on of power supply for the reversed movement of the output part is minimally 50 ms.
6. Delay after switching-off, i.e. time since a reaction of switches till the motor is dead can be maximally 20 ms.
7. It is recommended to have the corresponding direction protection switched-off directly with the corresponding position or torque switches.



**Abide by instructions of valve producers, whether switching-off in limit positions is to be realised with position or torque switches!**

#### After electric connection perform checking of function:

Put the valve manually to a mid-position.

Connect the EA electrically for the chosen direction of movement and watch the output part movement.

If it does not correspond change the order of feeding phases (valid for 3x400V version), or change leads of the feeding phase to the corresponding terminals (valid for 230V version).

Check the control unit switches connection with switching consequently the contacts of the corresponding switches with pressing the control elements at running of the EA (at proper connection) to the chosen direction. In case of proper connection the EA stops or indicates the adjusted position according to switching of the chosen switch. If any of the functions is fault check connecting of the switches according to wiring diagrams.



In the **SO 2-Ex version** with the built-in **electronic controller** it is needed to perform **autocalibration** for assuring optimal functioning.

### The procedure is as follows

Set the actuator to a mid-position (position and torque switches are not switched)

Press the button **SW1** for about 2 sec (i.e. till the **D3** diode is got on) to set the controller to the **autocalibration** mode. During this process the controller checks the feedback transmitter and the sense of turning, puts the EA to the positions open and closed, measures inertia mass in the directions "opening" and "closing", and loads the adjusted parameters into the EEPROM memory. In case that during the initialisation process an error occurs (e.g. in connection or adjustment) the initialisation process will be interrupted and the controller with the **D4** diode reports about the type of the error. Else after finishing the initialisation process the controller is put into the **regulation mode**. If needed to change adjusted parameters of the controller follow instructions given in the part Adjusting of actuator.



*Follow instruction of producers of valves, whether switching off in the limit positions should be arranged by the position or torque switches!*

### 3.2 Dismantling



***Before dismantling it is needed to disconnect power supply of the EA!  
Do not connect and disconnect the EA when live not to cause any injury by electrical current!***

- Switch the A off the mains.
- Disconnect the leads from the terminal board of the EA and loosen the cable from the plugs.
- Loosen the fixing screws of the flange and screws of the EA coupling and split the EA and the valve.
- If sending the EA to repair put it into a package steady enough not to allow its damaging.

## 4. Adjustment



**Keep safety regulations! Follow the prescribed procedure to assure that the EA is not connected to mains when live not to cause any injury by electrical current!**

After mechanical connection, electrical connection and checking of connection and function start setting and adjustment of the device. The adjustment can be performed at a mechanically and electrically connected EA. This part describes adjustment of EA to specified parameters in case that any unit of EA is reset. Laying of adjusters of the control board is shown on Fig. 1

### 4.1 Adjustment of the Torque Unit

The switching - off torques are adjusted by the producer for both directions, i.e. for the direction "opening" (the torque switch S1) as well as for the direction "closing" (the torque switch S2) to the specified value with tolerance of  $\pm 10\%$ . If not stated else they are adjusted to the maximum rate.

Adjustment and changing of settings of the torque unit to other torque values is possible using the adjusters according to Fig. 2. The switching - off torque can be only reduced with turning the adjusting screws with the scale against the adjustment lines on the torque unit arm. Setting to the longest line means that the switching - off torque is set to the maximum value. Setting to the lower line means reducing of the switching - off torque.



Fig.2

### 4.2 Adjustment of position-signalling unit (Fig.3)

The EA are in the production plant adjusted to a fixed stroke (according to the specification), given on the nameplate. Failure of the customer to specify the particular operating stroke parameter the selected operating speed are set to the 3rd stroke of the selected stroke line. While setting, adjusting and resetting follow these steps (Fig. 3):

- in the version with a resistant transmitter (Fig.4) disengage the transmitter;
- shift the sliding gear to the required speed as per Table 2, Fig. 3a by loosening the screw of the sliding gear and tighten it once resetting is over. When setting the sliding gear be particular about correct meshing with the given speed gear;
- loosen the nut (22) with simultaneous holding the central milled nut (23) and then loosen the nut (23) fixing the cams still having the Belleville springs which create axial thrust;
- reset the EA to the "Open" position and rotate the cam (29) clockwise (when viewing the actuating plate from above) until switch S3 switches over (25);
- reset the EA by the stroke where the "Open" position is to be indicated and turn the cam (31) clock-wise until switch S3 switches over (27);
- reset the EA to the "Closed" position and turn the cam (28) counter clockwise until switch S4 switches over (24);

- reset the EA back by the stroke where the “Closed” position is to be indicated and turn the cam (30) counter clockwise until switch S6 switches over (26);
  - once the EA is adjusted manually tighten the central milled nut (23) to lock the cams and tighten the lock nut (22) while simultaneous holding the milled nut;
  - swing the position indicator discs (31) for the given number of revolutions against the gauge mark on the top cover sight;
  - once of the position- signalling unit is adjusted also adjust the position Transmitter, converter or position control device, if necessary (according to the accessories of the EA).
- There is an option of bi-directional signalling at all operating stroke time, i.e. 100 %.

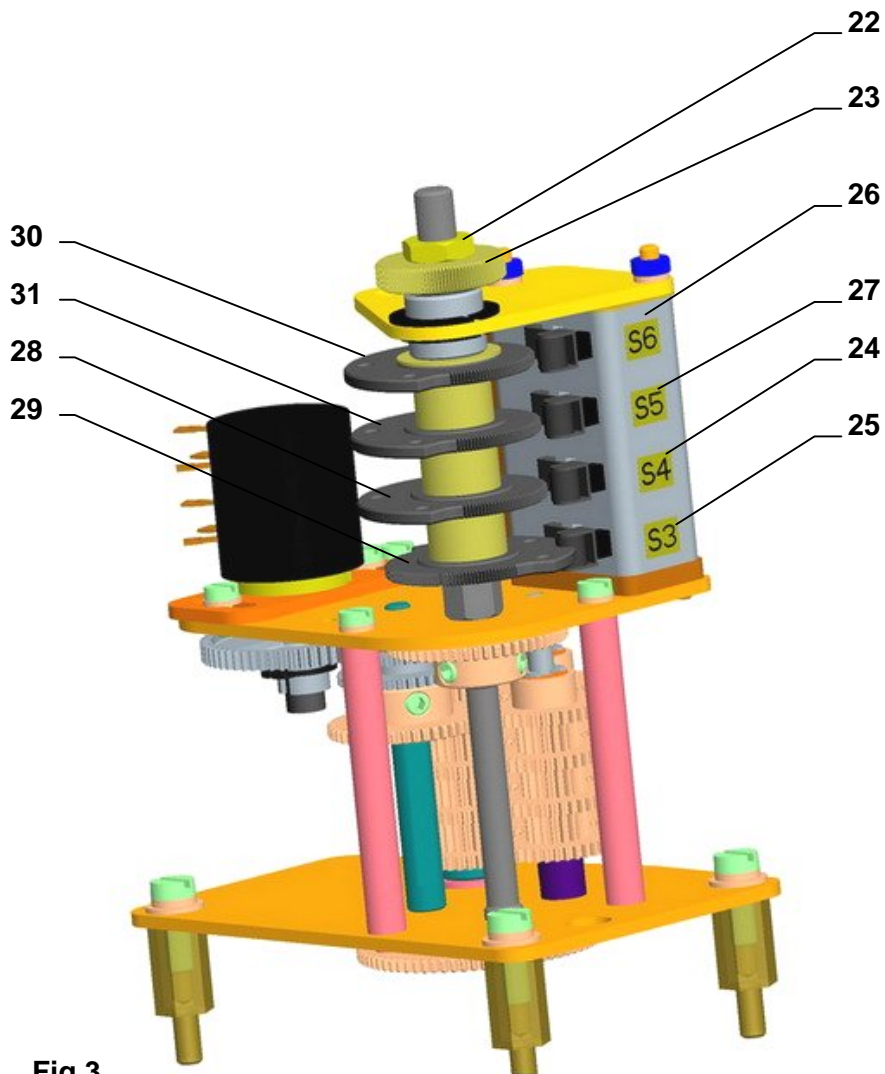

**Fig.3**

TABLE 2		
STROKE LINE	STROKE ANGLE	MAX. OPERATING SPEED
I.	1.°	3,125
	2.°	6,25
	<b>3.°</b>	<b>12,5</b>
	4.°	25
	5.°	50
	6.°	100
	7.°	200
II.	1.°	4
	2.°	8
	<b>3.°</b>	<b>16</b>
	4.°	32
	5.°	64
	6.°	128
	7.°	256
III.	1.°	5
	2.°	10
	<b>3.°</b>	<b>20</b>
	4.°	40
	5.°	80
	6.°	160
	7.°	320

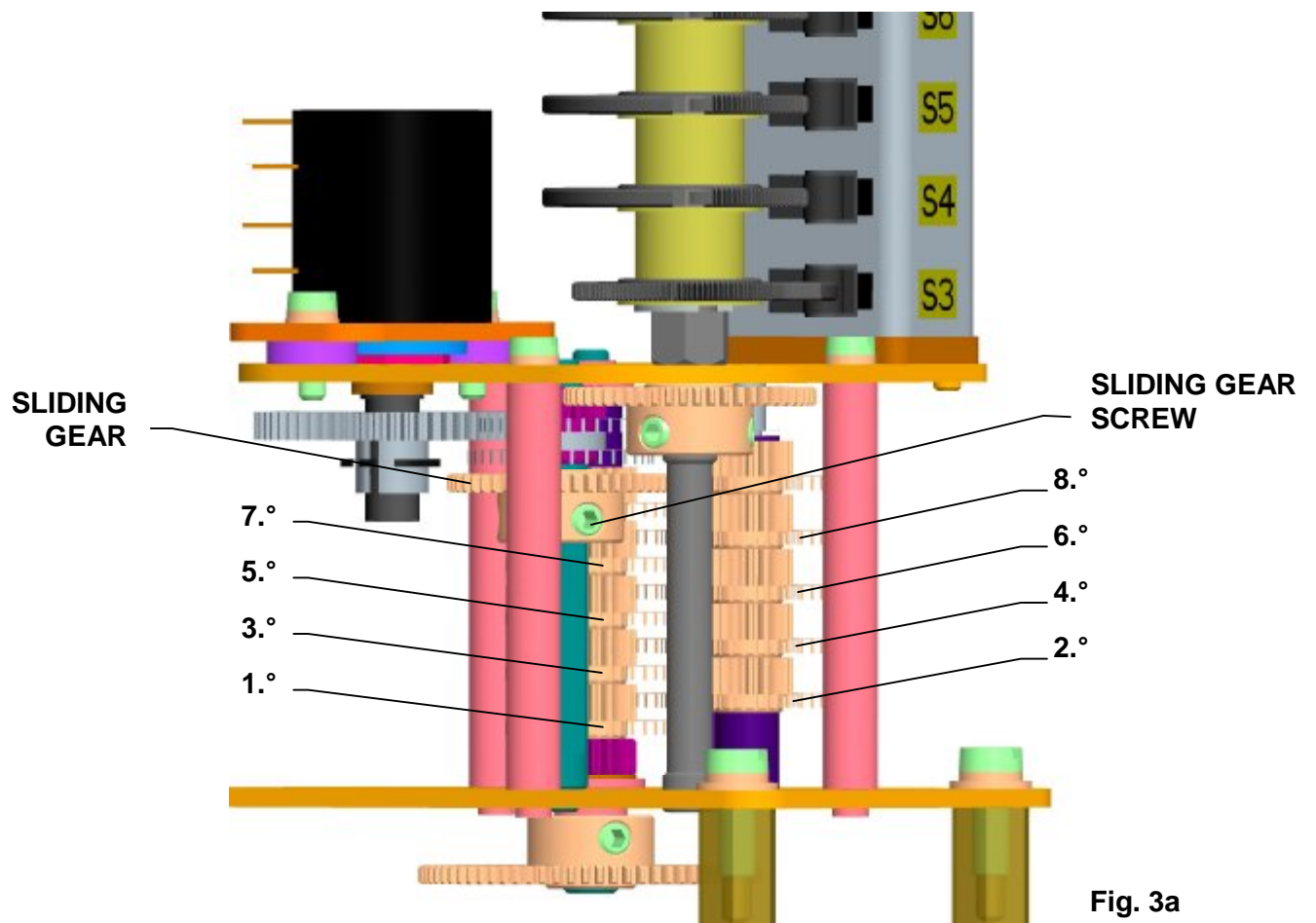

Fig. 3a

### 4.3 Adjustment of resistant transmitter (Fig.4)

The **resistant transmitter** is in the EA **SO 2-Ex** used to function as a remote position indicator; in the EA **SO 2 – Ex** to function as a feedback in the position controller.

Before the resistant transmitter adjustment the position switches have to be adjusted. Adjustment consists in setting of the resistance in the defined limit position of the EA.

Notes:

*In case that the EA is unused within the complete operating speed range following the stroke selected on the particular stroke line, the "Open" limit position resistance value will undergo proportional reduction.*

*In the EA SO 2-Ex with controller 2000W resistant transmitters are used. In the other cases if the resistant branch is lead to the terminal board the resistance of the transmitters is according to the customer's specification.*

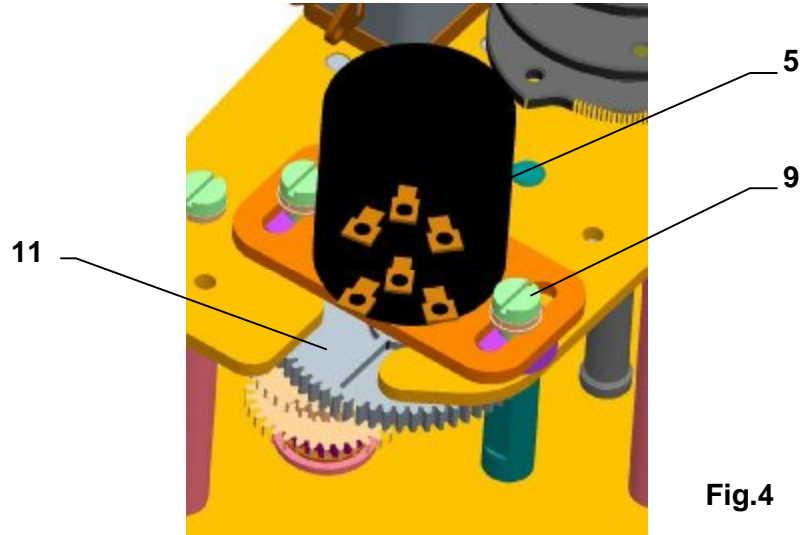

**Fig.4**

To adjust the transmitter follow these steps:

Loosen the fixing screws (9) of the transmitter holder and push the transmitter out of mesh.

Connect a meter for resistance measuring to the terminals 71 and 73 of the EA **SO 2-Ex** terminal board, or to the terminals 7 and 10 of the EA **SO-Ex with controller** terminal board.

Put the actuator to the position "closed" (with the handwheel, or with the local electric position control until the corresponding position switch S2 or S4 switches).

Rotate the transmitter shaft (11) until resistance of  $\leq 5\%$  of the nominal transmitter resistance can be read on the meter in case of EA **SO 2-Ex**, and 3 up to 5% of the nominal transmitter resistance in case of EA **SO 2-Ex with controller** with EPV , i.e. with the resistant transmitter with the converter PTK1.

In the position put the transmitter to mesh with the drive wheel and fix the fixing screws on the transmitter holder.

Please check the resistance value in both of the final positions and in case of need repeat the procedure. Once the device is adjusted in a correct way disconnect the meter from the terminal.

#### 4.4 Adjustment of the Electronic Position Transmitter (EPV) - the Resistive Transmitter (Potentiometer) with the Converter PTK 1

##### EPV – the 2-wire version (Fig. 5)

The position transmitter with the converter PTK1 is in the plant adjusted to have the output current signal on the terminals 81-82 as follows:

- in the position "open" ..... 20 mA
- in the position "closed" ..... 4 mA

If the transmitter requires a new adjustment follow these steps:

- Put the actuator to the position "closed" and switch the power supply off.
- Adjust the resistive transmitter according to the previous chapter. The resistance is to be metered on the terminals X-Y. The used transmitter resistance is 100 Ω.
- Switch the converter's power supply on.
- Turn the adjusting trimmer ZERO to adjust the output current signal rate measured on the terminals 81-82 to 4mA.
- Set the actuator to the position "open".
- Turn the adjusting trimmer GAIN to adjust the output current signal rate measured on the terminals 81-82 to 20mA.
- Check the output signal of the converter in the both limit positions, and repeat the procedure if needed.

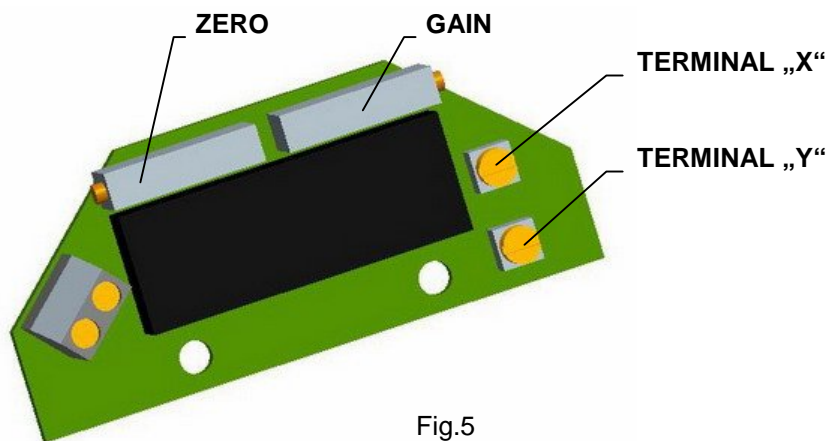

Fig.5

##### Note:

The output signal of 4-20mA can be adjusted at the range from 75 up to 100% of the rated stroke according to table Nr.3 . At values less than 75% the value 20mA is reduced proportionally.

##### EPV – 3-wire version (Fig. 6)

The resistive transmitter with the converter is in the plant adjusted to have the output current signal metered on the terminals 81-82 as follows:

- in the position "open" ..... 20 mA or 5 mA
  - in the position "closed" ..... 0 mA or 4 mA
- according to the specified version of the converter.

If the transmitter requires a new adjustment follow these steps:

- Put the actuator to the position "closed" and switch the power supply off.
- Adjust the resistive transmitter according to the previous chapter. The resistance is to be metered on the terminals X-Y. The used transmitter resistance is 2000 Ω or 100 Ω.
- Switch the converter's power supply on.
- Turn the adjusting trimmer ZERO to adjust the output current signal rate measured on the terminals 81-82 to 0 mA or 4mA.
- Set the actuator to the position "open".

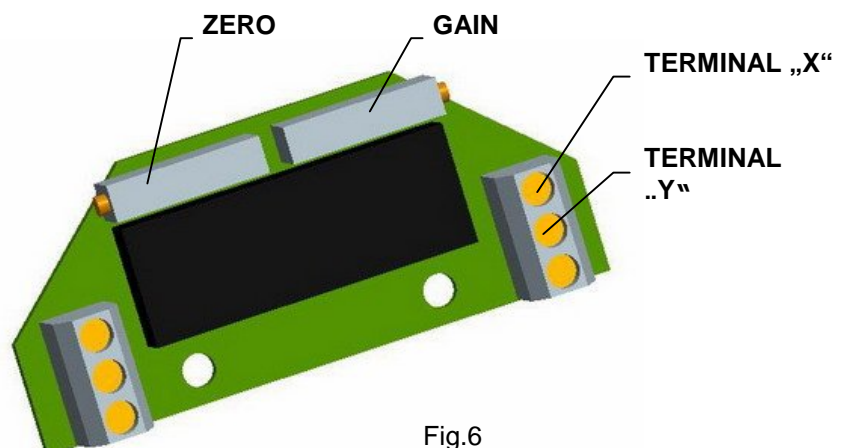

Fig.6

- Turn the adjusting trimmer GAIN to adjust the output current signal rate measured on the terminals 81-82 to 20mA or 5 mA.
- Check the output signal of the converter in the both limit positions, and repeat the procedure if needed.

Note:

The output signal of (0-20mA, 4-20mA or 0-5mA - according to the specification) can be adjusted at the range from 85 up to 100% of the rated stroke according to table Nr.3. At values less than 85% the value of the output signal is reduced proportionally.

#### 4.5 Adjustment of Capacitive Transmitter CPT1/A

The chapter describes adjustment of the capacitive transmitter to the specified parameters (standard values of output signals) in case they are reset. The capacitive transmitter serves as a position transmitter of electric actuators with unified output signal of 4÷20 mA in electric actuators **SO 2-Ex**, or as a feedback of a position controller, or if required it functions also as a remote position transmitter of electric actuators with unified output signal of 4÷20 mA in electric actuators **SO 2-Ex with controller**.

Note 1:

In case that reversed output signals are needed (in the position "OPEN" minimum output signal) contact personnel of service centres.

Note 2: In case of reverse output signal need (in position OPEN minimum output signal), please contact our service

The capacitive transmitter CPT1/A is adjusted by the producer to the fixed operation stroke according to the order and wired according to the wiring diagrams placed into the cover. Check the power supply of the user after connecting to terminal of the terminal board before the transmitter is electrically checked. Adjustment of the capacitive transmitter can be performed when the position switches are adjusted. The adjustment is performed with the power supply of 230 V/50 Hz and ambient temperature of  $20 \pm 5^\circ\text{C}$ .

The following versions of electric actuators with built capacitive transmitters can be specified:

- A) The version without any power supply** (2-wire version) for EA **SO 2-Ex**
- B) The version with a power supply** (2-wire version) for EA **SO 2-Ex**
- C) The version CPT as a feedback to the position controller** for EA **SO 2-Ex with controller**

##### A.) Adjustment of the Capacitive Transmitter without any Power Supply

Before connecting check the power supply. The measured voltage should be in range from **18 up to 28 V DC**.



The voltage of the power supply **must not be in any case higher than 30 V DC**. The transmitter can be irreversibly damaged!

While checking or adjusting the output signal of 4÷20 mA follow these steps:

- Connect a mA meter of precision class 0,5 and loading resistance lower than  $500 \Omega$  serially with the transmitter (pole "-"; terminal 82)
- Put the actuator to the position "CLOSED", the signal value should decrease.
- Check the signal value for the position "CLOSED" (4 mA).
- Tune the signal with loosening the fixing screws (15) and turning the trimmer (10) until the required value of 4 mA is reached. Tighten the fixing screws.
- Put the actuator to the position "OPEN", the signal value should raise.
- Check the signal value for the position "OPEN" (20 mA).
- Tune the signal with turning the trimmer (20) until the required value of 20 mA is reached.
- Check the signal value for the position "CLOSED" and then for the position "OPEN".

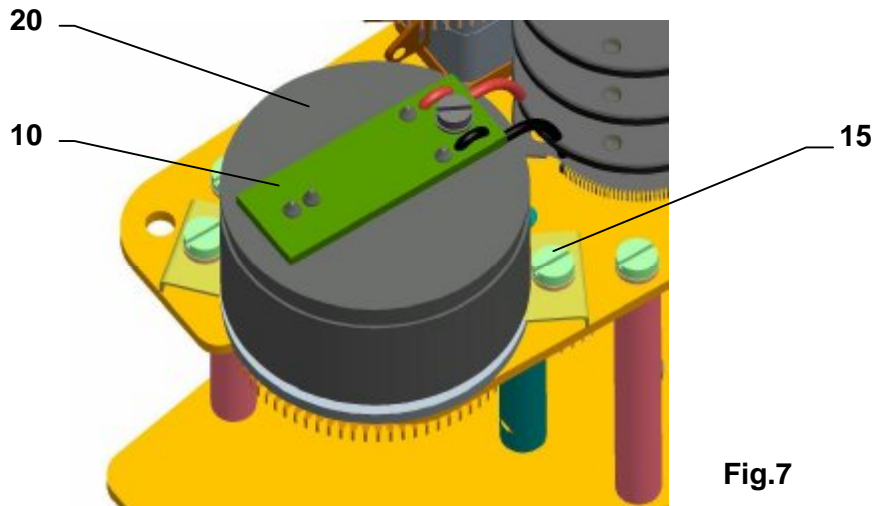

**Fig.7**



- Repeat the procedure until the change from 4 to 20 mA is reached with deviation less than 0,5 %.
- Disconnect the meter and lock the screws with a varnish.

### **B.) Adjustment of the Capacitive Transmitter with the Power Supply**

1.) Check the power supply: 230 V AC  $\pm 10\%$  on the terminals 1,61, resp. 78,79

2.) While checking or adjusting the output signal of 4÷20 mA follow these steps:

- Connect a mA meter of precision class 0,5 and loading resistance lower than 500  $\Omega$  on the terminals 81, 82.
- Follow the procedure described in the previous chapter A.

### **C.) Adjustment of the Capacitive Transmitter Served as a Feedback of the Position Controller**

While checking or adjusting the output signal of 4÷20 mA follow these steps:

- Disconnect the circuit on the terminals 81 and 82 removing the jumper.
- Connect power supply to the terminals 1 and 61.
- Disconnect the control signal from the terminals 86/87 and 88.
- Put the actuator to the direction "OPENING" or "CLOSING" with the handwheel or connecting power supply to the terminals 1 and 20 for the direction "OPENING", or 1 and 24 for the direction "CLOSING".
- Connect a mA meter of precision class 0,5 (e.g. digital) and loading resistance lower than 500  $\Omega$  on the terminals 81,82.
- Follow the procedure for the version without any power supply described in the previous chapter A.
- Having the transmitter adjusted put the jumper again on the terminals 81 and 82 in case that the output signal wont be used (the circuit through the terminals 81 and 82 should be closed).
- Connect the control signal to the terminals 86/87 and 88



*The user has to arrange grounding of the 2-wire circuit of the capacitive transmitter to the electrical ground of a joined controller, computer, etc. The grounding should be performed only in one place in any part of the circuit outside the electric actuator!*

*In the version equipped with the controller device while using the feedback from transducer CPT; when using the output signal there has been no galvanic isolation of the signal from the input one!*

#### Note:

*The trimmer (20) can be used to adjust the output signal of the capacitive transmitter to any value of operation stroke in range from ca 40% up to 100% of the value of the operation stroke adjusted by the producer and stated on the actuator's nameplate.*

### 4.6 Adjustment of position controller (Fig. 9)

The built-in position controller REGADA of new generation is a user-friendly control system to control actuators with an analogue signal. The controller takes advantages of high-power RISC processor MICROCHIP to perform all functions. It provides also continuous automotive diagnostics of the system, error messages as well as number of relay switching and number of controller's operation hours. Placing an analogue signal onto the input terminals of the terminal board 86/87 (GND, -) and 88 (+) causes that the EA output is reset.

Required parameters and functions can be programmed using function buttons SW1 - SW2 and LED diodes D3 - D4 placed directly on the controller, see Table 2.

#### 4.6.1 Setting of controller

The controller's microprocessor unit is in the production plant programmed to parameters given in **Table 2** (Note 2).

Setting of the controller is performed using buttons and LED diodes.

Adjust the position and torque switches and the position transmitter before adjustment of the controller.

Laying of adjusters and signalling elements on the board of the REGADA controller is shown on Fig. 9:

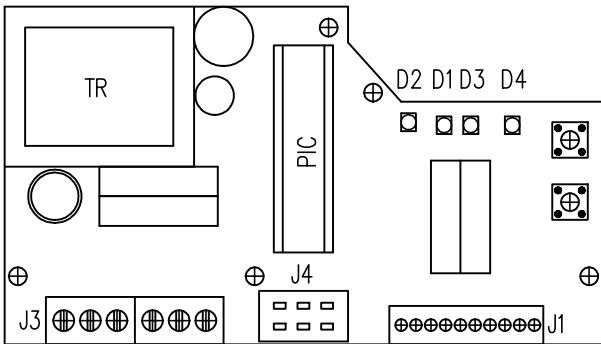

<b>SW1 button</b>	starts an initialization routine and allows listing in the adjust menus
<b>SW2 button</b>	setting of parameters in the chosen menu
<b>D1 diode</b>	power on indication
<b>D2 diode</b>	motion to the direction "opening" indication (green) - "closing" (red) indication
<b>D3 diode</b>	(yellow light) number of blinking codes indicates chosen adjust menu
<b>D4 diode</b>	(red light) number of blinking codes indicates adjusted parameter of the controller from the chosen menu

Fig. 9

**Table 2:**

D3 (yellow) diode number of blinking	Adjust menu	D4 (red) diode number of blinking	Adjusted parameter
1 blink	control signal	1 blink	0-20mA
		2 blinks	<b>4-20 mA (*) (**)</b>
		3 blinks	0-10V DC
2 blinks	response for signal SYS-TEST	1 blink	EA opens receiving signal SYS
		2 blinks	EA closes receiving signal SYS
		3 blinks	<b>EA stops receiving signal SYS (*)</b>
3 blinks	mirroring (ascending/descending characteristics)	1 blink	EA CLOSING at increasing of control signal
		2 blinks	<b>EA OPENING at increasing of control signal (*)</b>
4 blinks	insensitiveness of controller	1 to 10 blinks	insensitiveness of controller of 1-10% (3% set by the producer) (*)
5 blinks	way of regulation	1 blink	narrow torque
		2 blinks	<b>narrow position (*)</b>
		3 blinks	wide torque
		4 blinks	wide position

Notes:

- The controller at autocalibration automatically sets the feedback type - resistant/current
- (\*) Parameters set in the production plant, if customer has not stated else.
- (\*\*) Input signal 4 mA - position "closed" 20 mA - position "open"

**Standard setting of controller (programmed RESET of controller)** - in case of any problems with setting of the parameters it is possible with pressing both **SW1 and SW2** at the same time and then switching power on to set the standard parameters. Long press the push-buttons till the yellow LED starts flashing.

### Controller setting procedure:

The **initialization routine** starts at the switched-on controller, zero system deviation and short pressing of the **SW1** button for ca 2 sec (i.e. until the diode **D3** got on). Loosing the button some of the default menus starts (usually control signal) what is shown with 1 blink on the **D3** diode as well as one of the default parameters (usually control signal of 4-20mA) what is shown with 1 blink on the **D4** diode. Then the required parameters of the controller can be changed according to Table 2:

press shortly the **SW1** button to list the menu shown with the blinking number on the **D3** diode.

press shortly the **SW2** button to set parameters shown with the blinking number on the **D4** diode.

After changing of the parameters according to user's wishes, put the controller to **autocalibration** with pressing the **SW1** button for ca 2 sec (i.e. until the diode D3 got on). During this process the controller performs the feedback transmitter and turning sense checking, sets actuator to the positions "open" and "closed", measures inertia mass in the directions "opening" and "closing", and loads the adjusted parameters into the EEPROM memory. In case that during the initialization process an error occurs (e.g. in connection or adjustment) the initialization process will be interrupted and the controller with the **D4** diode reports about the type of the error. Else after finishing the initialization process the controller is put into the **regulation mode**.

### Error messages of the controller with D4 diode at initialization

4 blinks.....improper connection of the torque switches

5 blinks.....improper connection of the feedback transmitter

8 blinks.....bad sense of actuator's turning direction or adverse connection of the feedback transmitter

### 4.6.2 Watching operation and error states

Watching operation and error states is possible with the EA open.

#### a) Operation status with the D3 LED diode signalling:

it is continuously lighting - the controller regulates

it is continuously not lighting - system deviation in the insensitiveness range - the EA has stopped

#### b) Error state with the D4 and D3 LED diodes signalling - D4 continuously lighting,

1 blink (repeated):	indication of the "TEST" mode - the EA is put to the position according to the signal in the "TEST" menu (at connecting the 66 and 86/87 terminals)
2 blinks (repeating after short pause)	missing of control signal - the EA is put to the position according to the signal in the "TEST" menu
4 blinks (repeating after short pause)	torque switches activity indication (the EA switched-off with the torque switches in a mid-position)
5 blinks (repeating after short pause)	failure of the feedback transmitter - the EA is put to the position according to the signal in the "TEST" menu
7 blinks (repeating after short pause)	control signal (current at range 4-20mA less than 4mA (3.5mA)).

## 5. Service and Maintenance

### 5.1 Service



1. *In general it is supposed that the EA is serviced by a qualified person as required in the Chapter 1!*
2. *After the EA is put into operation it is necessary to check whether during manipulation its surface finishing was not damaged – the damages should be eliminated to prevent the surface against deterioration caused by corrosion!*

- The EA requires just an insignificant service. The reliable operation is determined by the correct putting into operation.
- The service of the EA results from the operation conditions and generally consists in treating the information for subsequent performing of a required function. The EA can be controlled by remote control electrically or manually on the place of their installation. The manual control is available with a hand wheel.
- The service staff should arrange the required maintenance and prevent the actuator during operation against impacts of environment and climate what exceed the frame of allowed influences stated in the Chapter "Operation Conditions".
- It is necessary to avoid overheating of the EA surface, exceeding of parameters stated on the nameplate and abnormal vibrations of the EA.

#### Manual control:

- If the manual control is needed (adjustment, function checking, failures etc.) the staff can reset the regulated member using the handwheel. While rotating the handwheel clockwise the output element moves in the direction "CLOSING".

### 5.2 Maintenance – Its Scope and Periodicity

During inspections and maintenance it is needed to tighten all screws and nut that influence tightness and protection enclosure.

Maintenance consists also in lubrication. Exchanging or filling the lubricator during first years of operation is not required. The exchange or filling the lubricator up is needed during inspections. The interval between two preventive inspections is four years.

**Lubricators** – grease HF 401/0 (GLEIT-μ) or GLEITMO 585 K

- in versions for climate with temperatures -50°C till +40°C grease ISOFLEX TOPAS AK 50.



*The valve's stem should be lubricated independently on the EA maintenance*

- Each 6 months it is advised to perform an inspection movement in the frame of the set operation stroke to check reliability of functioning, and to put it back to the origin position.
- If in the inspection regulations not stated else perform the inspection of the EA once a year and check and tighten all connecting and earthing screws to reduce heating.
- After 6 months of operation and then once a year it is advised to check the fixing screws between the EA and the valve whether they are tighten enough (tighten them in cross way).



- While connecting and disconnecting of the EA check the sealing rings of the cable leads – damaged and worn sealing should be replaced by original rings!
- Keep the EA clean and take care about removing impurities and dust. The cleaning has to be performed regularly according to the operation possibilities and requirements.

### 5.3 Maintenance to assure inexplosiveness

A half an hour before removing of the actuator cover it is needed to switch power supply off. The given period is required to assure cooling of the electric motor and the space heater below the admissible temperature value of the temperature class T5 (+100°C).

The fixing screws of the upper cover have to be always in full numbers, i.e. 4 pcs, with flexible washers and tightly fastened.

The actuators with damaged closing surfaces, e.g. scratches, rifts, etc. have to be immediately put out of operation.

- While connecting and disconnecting of the EA check the sealing rings of the cable leads – damaged and worn sealing should be replaced by original rings!
- Keep the EA clean and take care about removing impurities and dust. The cleaning has to be performed regularly according to the operation possibilities and requirements.
- Reparation of EA (basically the parts the resisting closures consist with, have substantial influence on safety) is allowed perform only by producer, witch according to certificated documentation and by performing of required tests (inclusive of static pressure test of resisting clouser parts guarantee the fulfil required standardes and rules for this products.

#### The closing surfaces are (Fig.10):

the connecting surface of the upper cover and the lower case (1),

the cylinder part of the manual control mechanism flange and shaft (2),

the cylinder part of the lower case and the cylinder part of the manual control mechanism flange (3),

the cylinder part of the lower case and the cylinder part of the crown wheel flange (4).

the cylinder part of the crown wheel and of the indication shaft (5)

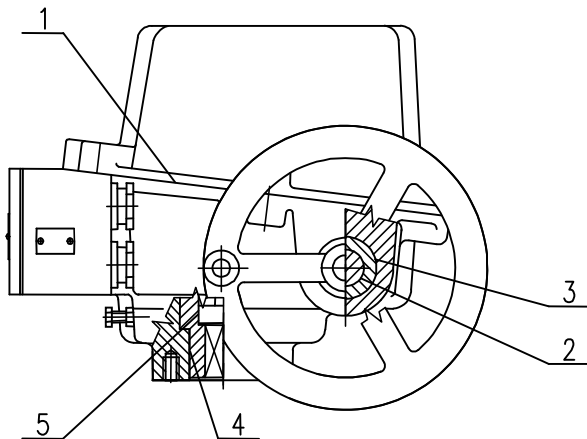

Enclosure joint surfaces are designed according to the requirements of table 2 and 3, EN 60079-1,

To seal the gaps against entry of fluids and dust, O-rings are used from the outside except for the gap of flameproof enclosure.



#### Caution:

After disassembly and re-assembly of top enclosure and bottom enclosure (see gap of flameproof enclosure 1 in chapter 5.3) the sealing O-ring must be replaced according following table:

O- Ringlet	PNm	Material	Manufacturer
Bottom upper cover and the lower case	62 732 XXX	NBR	TRELLEBORG SEALING SOLUTIONS resp. MEGAbelt SK, s.r.o.

## 5.4 Troubleshooting

- In case of a mains failure the EA stands in the position where it was before the failure occurred. If needed the EA can be reset using the manual control (with the handwheel). When necessary EA can be manually operated (hand wheel), at doing this, pay attention to keep the movement of the EA output part within the range of the set stroke so as to avoid losing the adjustment of the limit position switches or position transmitter or regulator. After supply voltage recovery EA is prepared for operation.
- In case of a failure of a part of the EA the part can be replaced by a new one. The exchange is to be committed by the producer or a contracted service firm.
- In case of an EA failure, which cannot be eliminated directly in operation, follow instructions for under-guaranty and after-guaranty service.
- For controller repair a F1,6 A subminiature fuse for PCB should be used, alternatively also F 2A, 250 V e.g. Siba type 164 050.1,6 or MSF 250, and for DB .... voltage source repair a M160 mA, 250V fuse, e.g. Siba, or MSF 250.

Failure	Cause	Troubleshoot
There are no revolutions of motor rotor when operating the push-buttons.	1. No voltage on the electric motor connectors.	Check connection and voltage presence.
	2. No voltage on the control part.	Check connection of the control part.
The EA fails to stop at the limit positions.	1. Incorrect setting-up of the switches.	Perform adjustment.
	2. The microswitch is defective	Replace the microswitch for a new one and adjust.
The EA stops at the mid-position.	There is an obstacle in the valve or part of it seizes.	Perform reversing of the EA, move it to the original direction and, in the case that the failure repeats, repair the armature.
There is no indication of reaching these positions in the final positions.	1. The LEDs fail to operate.	Replace the LEDs for new ones.
	2. Incorrect adjustment of the position signal switches.	Adjust the position signal switches.
		In case that some EA failures still remain, contact the service centres.

*Note: If the EA has to be dismantled follow the procedure of the Chapter "Dismantling"*



*The EA can be dismantled to be repair purpose by qualified and trainer persons only! The training can be preformed by the producer or by a contracted service firm.*

## 6. Accessories and Spare Parts

As accessories the **handwheel** is packed with the product.

## 7. Enclosures

### 7.1 Wiring diagrams SO 2-Ex

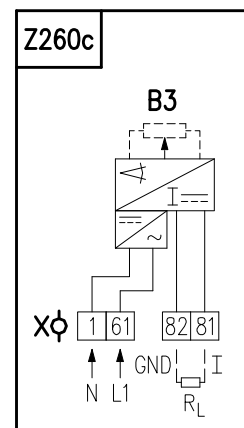
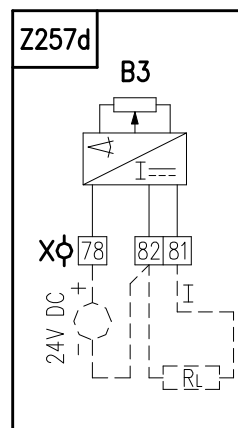
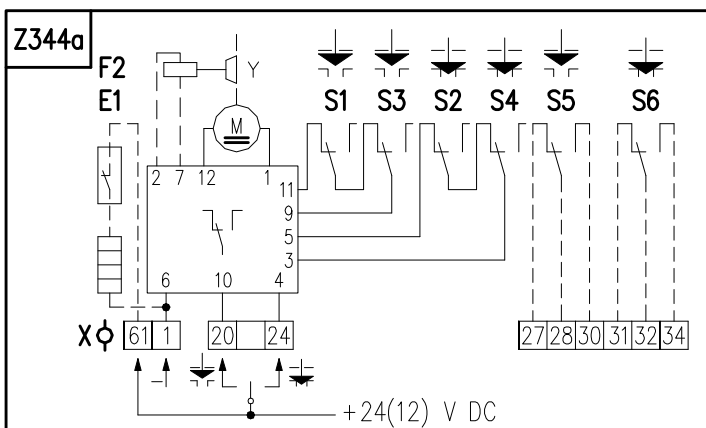
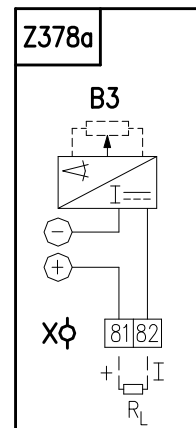
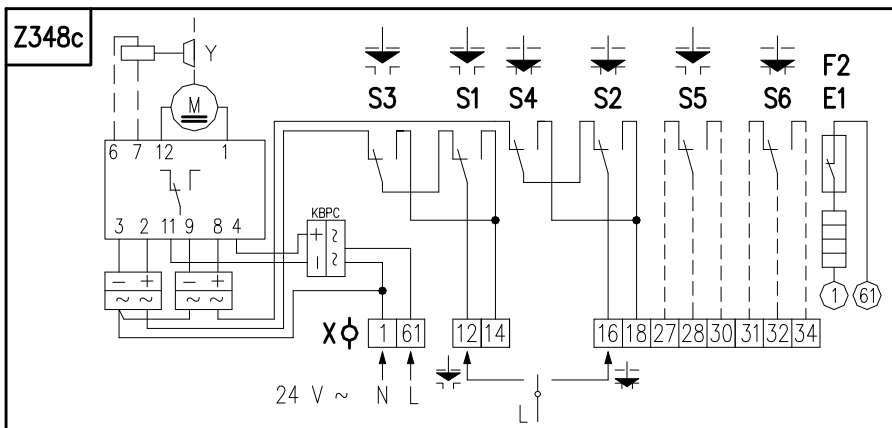
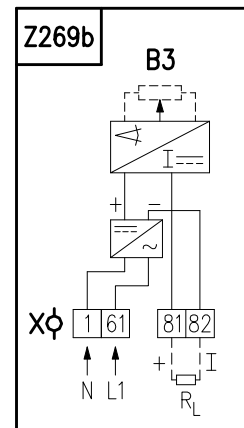
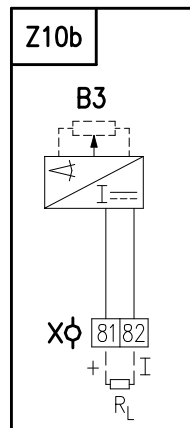
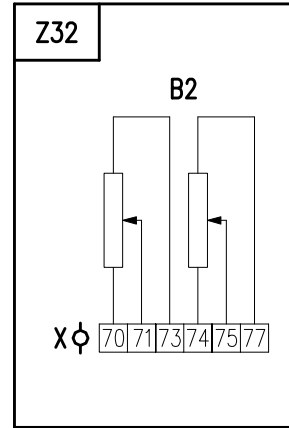
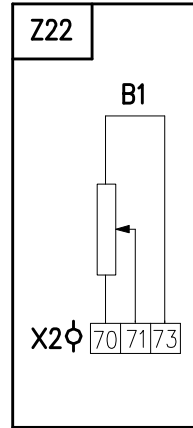
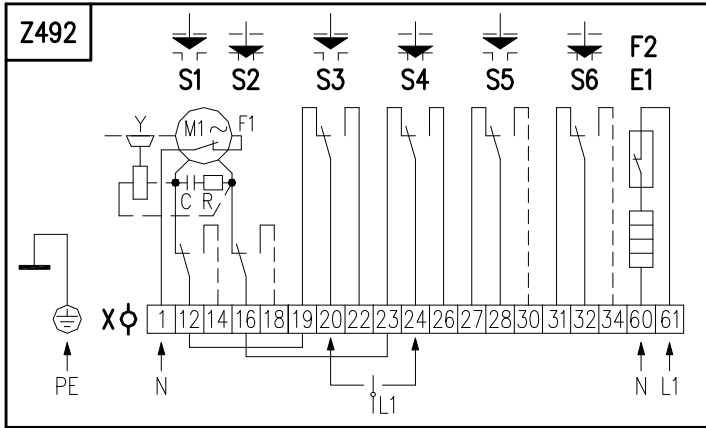

7.2 Wiring diagrams SO 2-Ex with controller

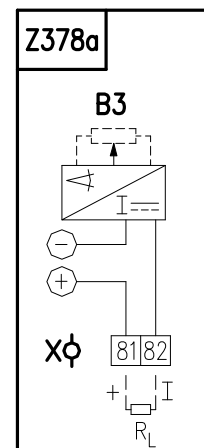
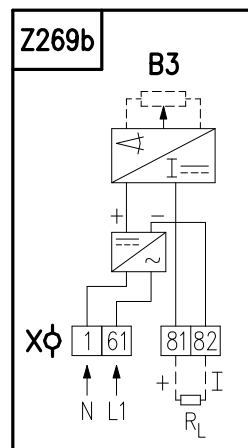
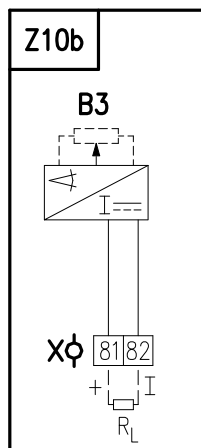
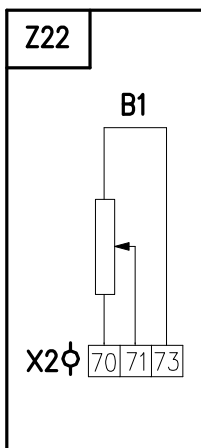
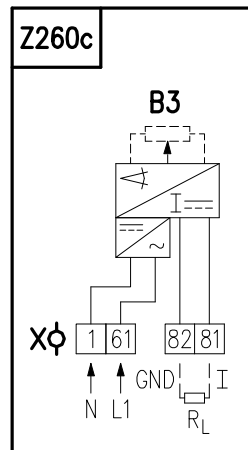
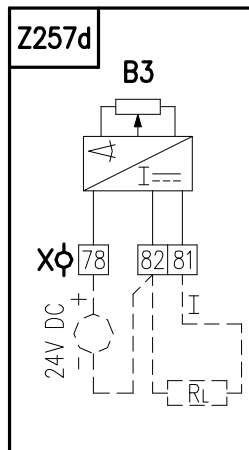
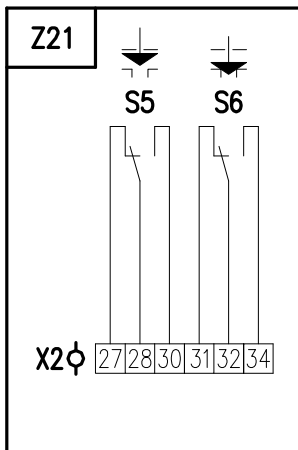
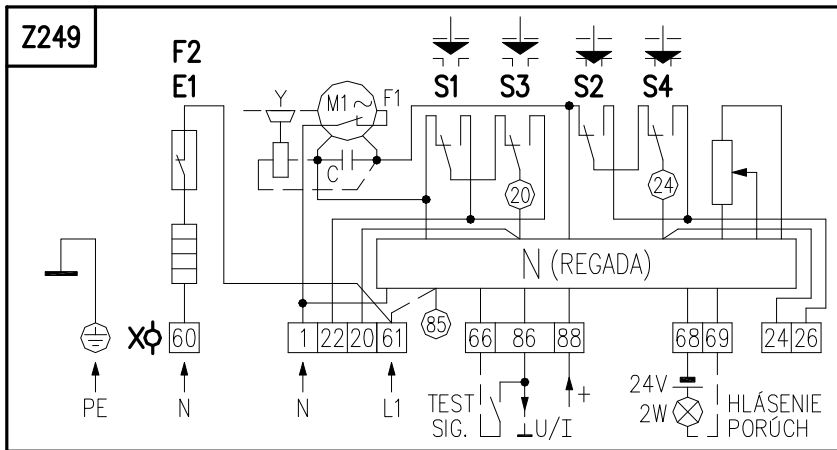
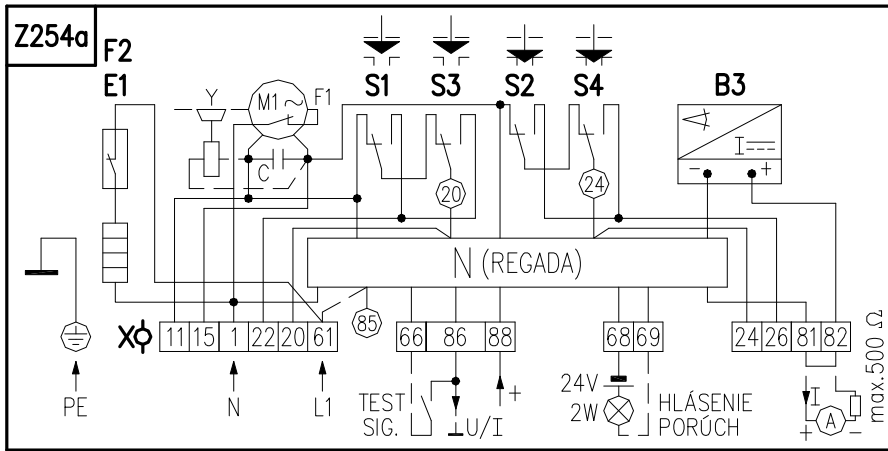



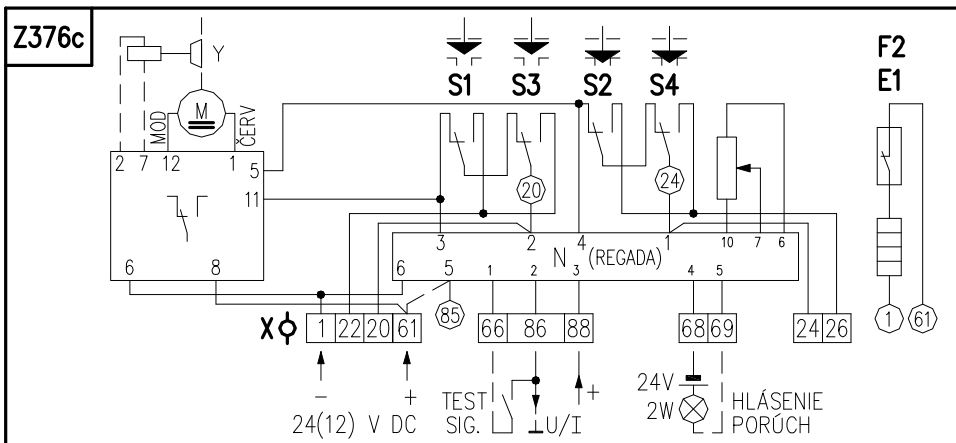
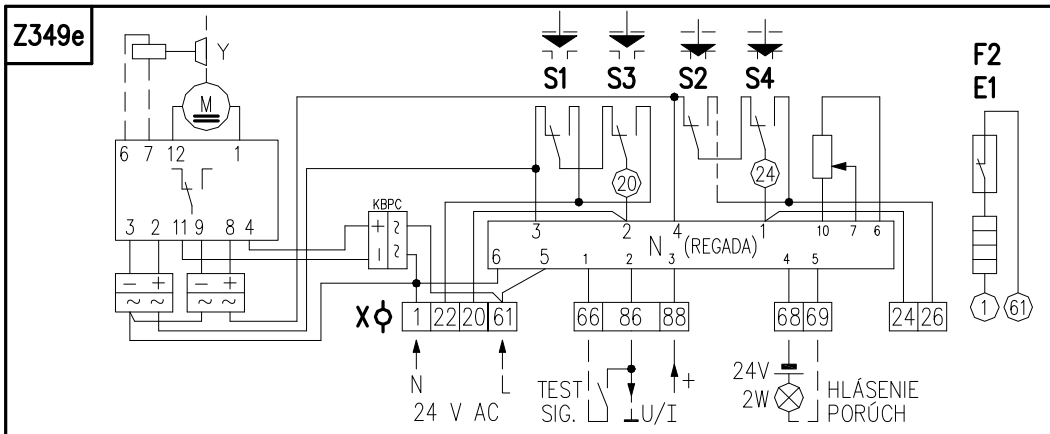
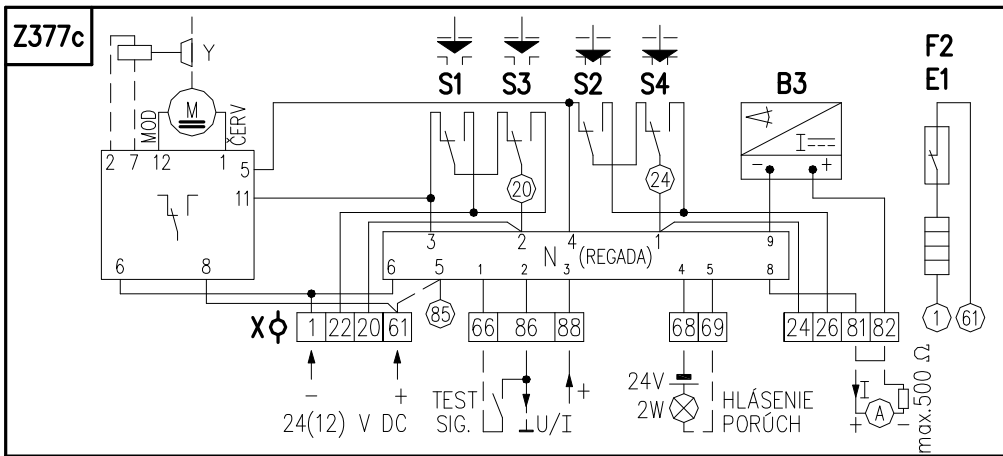
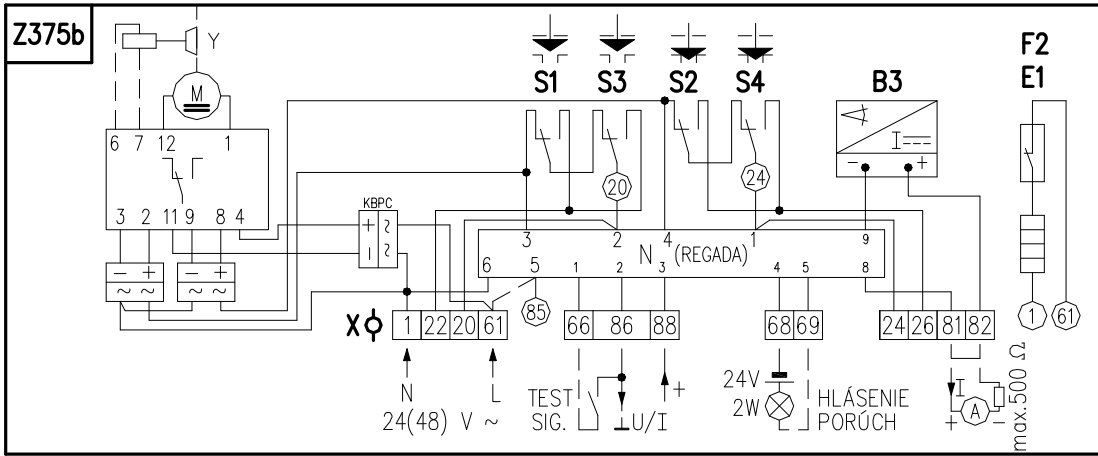

**Legend:**

- Z10b .....wiring diagram of resistive with current converter or capacitive transmitter - 2-wire without supply
- Z21 .....wiring diagram of additional position switches connection for EA SO 2-Ex
- Z22 .....wiring diagram of single resistant transmitter
- Z32 .....wiring diagram of double resistant transmitter
- Z254a.....wiring diagram of EA SO 2-Ex with controller and current feedback for electric motor – for 230 V AC
- Z249.....wiring diagram of EA SO 2-Ex with controller with resistant feedback – for 230 V AC
- Z257d.....3-wire version of EPV - without power supply
- Z260c.....3-wire version of EPV - with power supply
- Z269b.....wiring diagram of resistive transmitter with current converter or capacitive transmitter -2-wire version with power supply
- Z344a.....wiring diagram of EA SO 2-Ex with electric motor 24 V DC
- Z348c.....wiring diagram of EA SO 2-Ex with electric motor 24 V AC
- Z349e.....wiring diagram of EA SO 2-Ex with controller with resistant feedback for electric motor 24 V AC
- Z375b.....wiring diagram of EA SO 2-Ex with controller with current feedback electric motor 24 V AC
- Z376c.....wiring diagram of EA SO 2-Ex with controller with resistant feedback for electric motor 24 V DC
- Z377c.....wiring diagram of EA SO 2-Ex with controller with current feedback electric motor 24 V DC
- Z376a .....wiring diagram of resistive with current converter or capacitive transmitter 2 - wire with supply – for 24 V DC
- Z492.....wiring diagram of EA SO 2-Ex with electric motor 230 V AC

- |  |  |
|--|--|
| B1..... resistive transmitter (potentiometer) single | R..... resistor (for the version of 230 V AC)                  |
| B2..... resistive transmitter (potentiometer) double | R <sub>L</sub> ..... voltage-dropping resistor (for 230V only) |
| B3..... capacitive transmitter                       | S1..... torque switch "open"                                   |
| E1..... space heater                                 | S2..... torque switch "closed"                                 |
| F1..... electric motor thermal protection            | S3..... position switch "open"                                 |
| F2..... space heater thermal switch                  | S4..... position switch "closed"                               |
| I/U ..... input (output) current (voltage) signals   | S5..... additional position switch "open"                      |
| M..... electric motor                                | S6..... additional position switch "closed"                    |
| C ..... capacitor                                    | X..... terminal board  |
| N ..... position controller                          | Y..... brake of electric motor                                 |

*Note 1* In case, that output signal from the capacitive transmitter (wiring diagram Z254a, Z377c, Z375b) is not used (incomplete circuit between terminal 81 and 82), it is required to connect clamps 81 and 82 by jumper (jumper is connected at manufacturing plant for connecting to terminal board only). By using output current signal from capacitive transmitter it is needed to remove jumper.

*Note 2:* In the version equipped with the controller device while using the feedback from transducer CPT; when using the output signal there has been no galvanic isolation of the signal from the input one!

*Note 3:* In case that galvanically separated output signal is needed it is necessary to use galvanical separation element (is not part of delivery), e.g. NMLSG.U07/B (producer SAMO Automation s.r.o.). After discussion this module could be supplied by EA producer.

*Note 4:* Terminals 14, 18, 30 and 34 are not terminated in wiring diagram Z492 for specification with double resistant transmitter. Terminals 14 and 18 are not terminated in version as for specification with single resistant transmitter or 3-wire electronic position transmitter, without power supply.

**SWITCH OPERATION CHART**

	terminals	open	close
S1	11 (M2) - 12		
	12 - 14		
S2	15 (M3) – 16		
	16 – 18		
S3	19 – 20		
	20 - 22		
S4	23 – 24		
	24 - 26		
S5	27 – 28		
	28 – 30		
S6	31 – 32		
	32 - 34		

	Contact closed.
--	-----------------

	operating stroke
--	------------------



P-1440

ISO 5210, F10  
P

4xM10x20

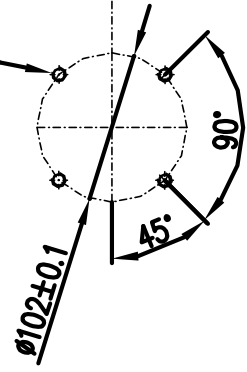

ISO 5210, B3  
non-standard, E

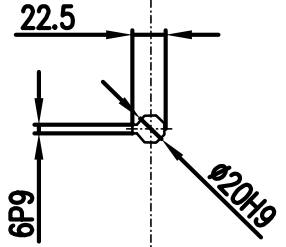

DIN 3338, C  
non-standard, C

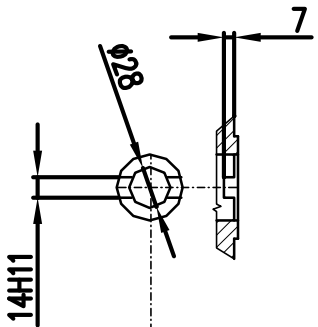

P-1440/B	60	non-stand,, E	non-stand, C
P-1440/A	70	ISO 5210, B3	DIN 3338, C
Version	D	Connection according to standard	

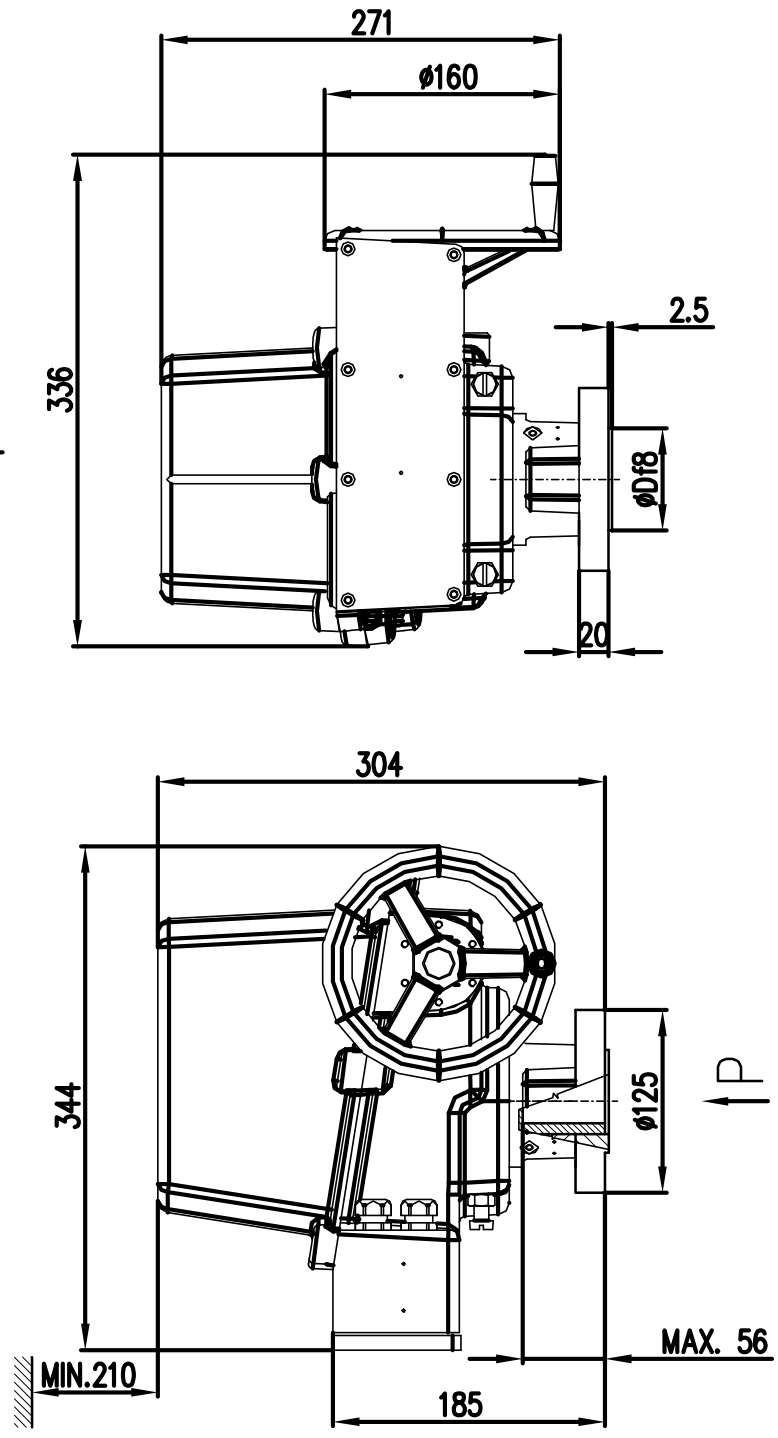

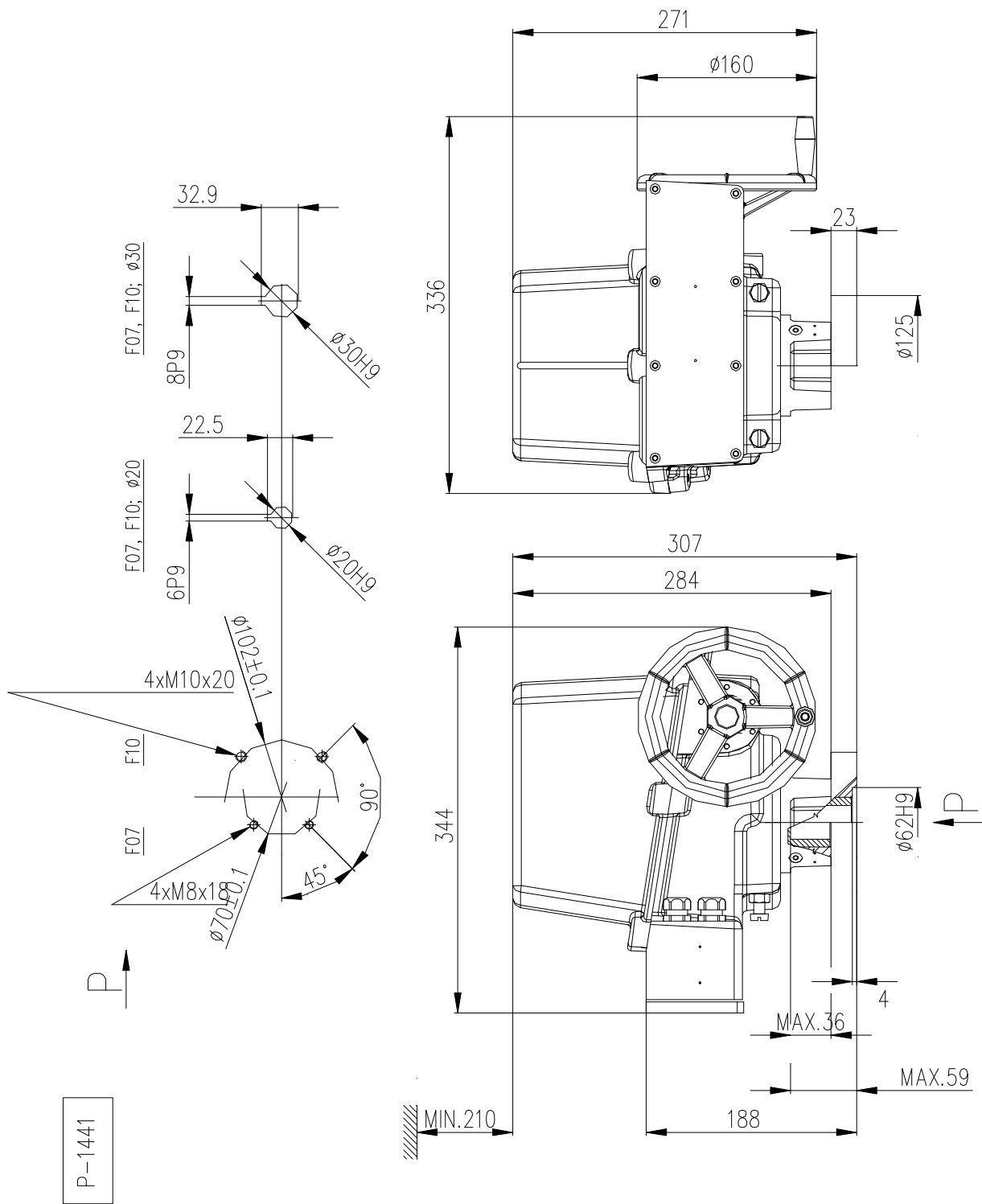

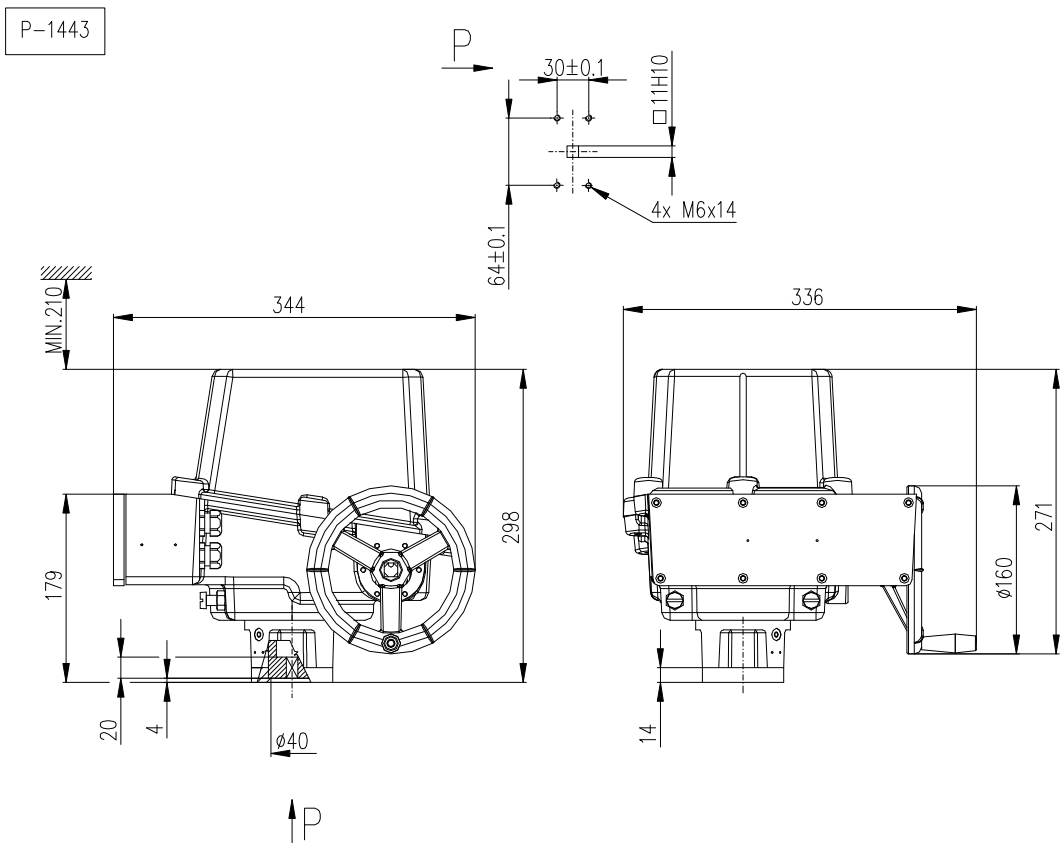
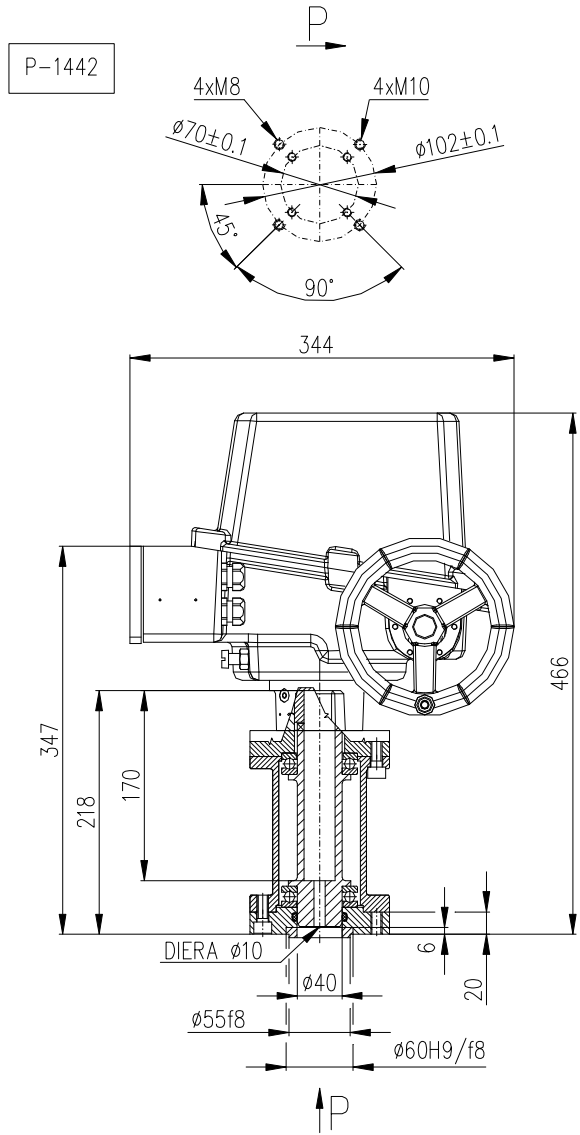

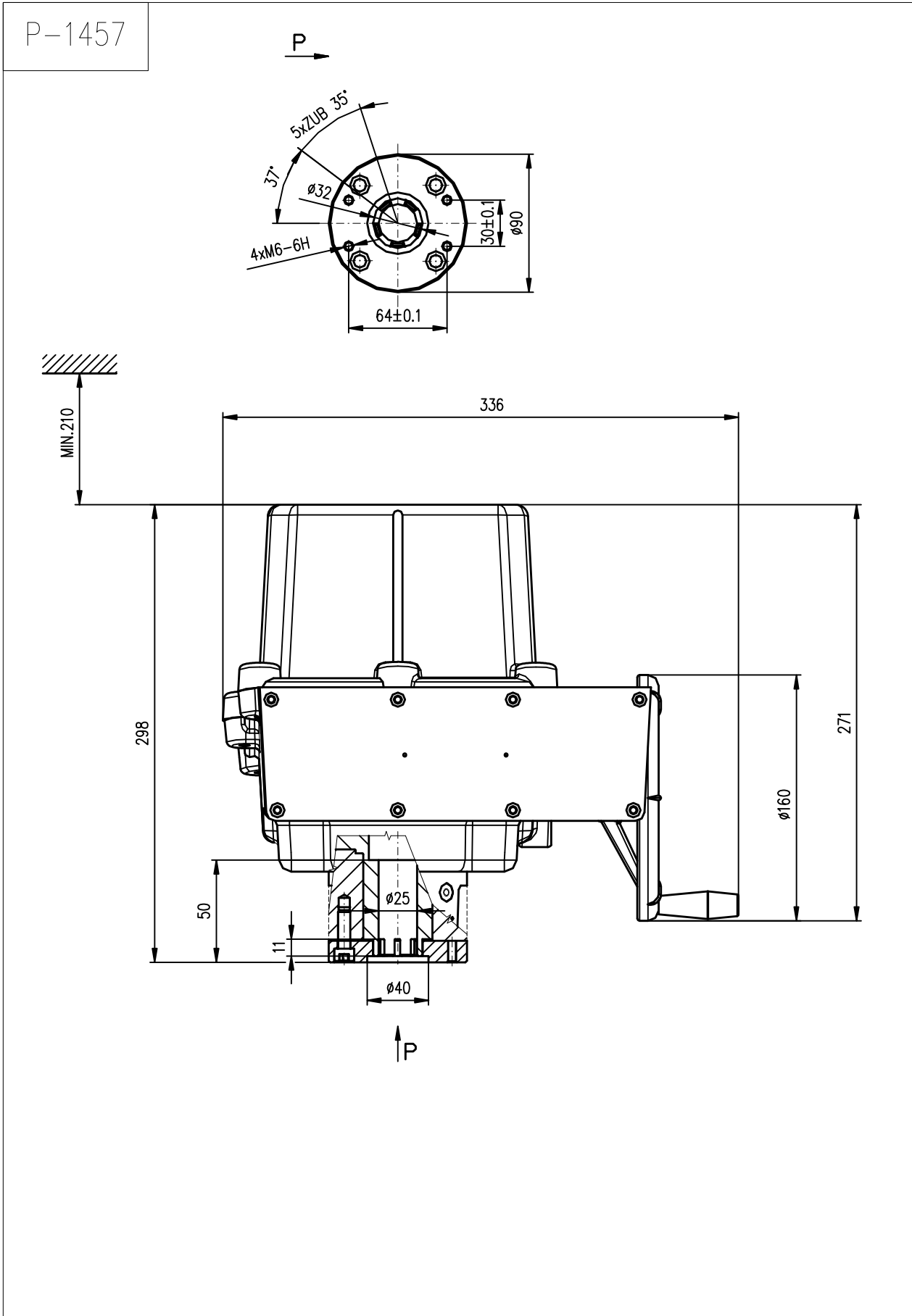

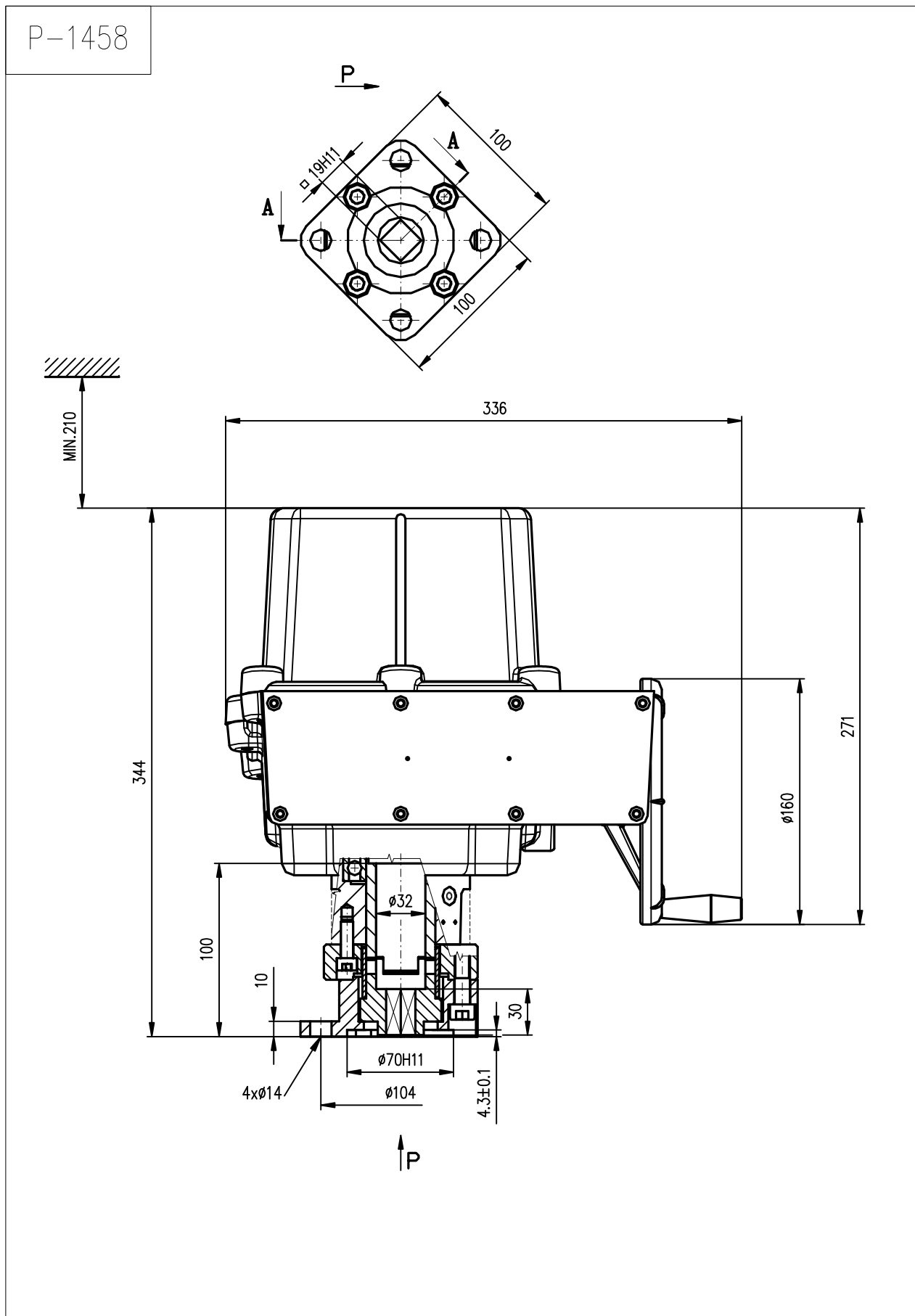



P-1459

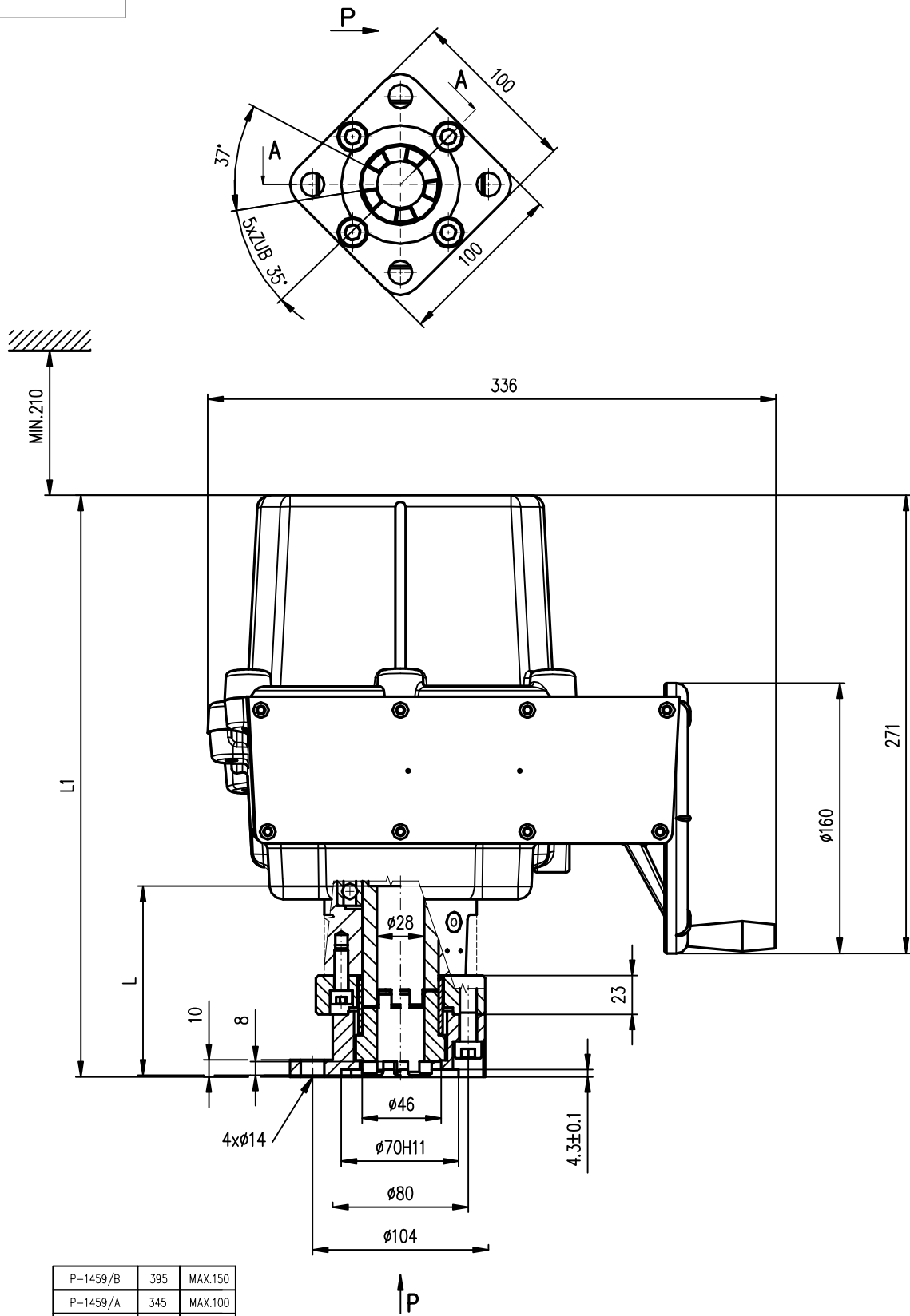

P-1459/B	395	MAX.150
P-1459/A	345	MAX.100
VYHOTOVENIE	L1	L

**7.4 Guarantee service check report**

<b>Service center:</b> D	
<b>Date of repair:</b>	<b>Guarantee repair no.:</b>
<b>User of actuator:</b>	<b>Claim applied by:</b>
<b>Actuator type number:</b>	<b>Actuator production number:</b>
<b>Product claim fault:</b>	<b>Detected product fault:</b>
<b>Used spare parts:</b>	
<b>Remarks:</b>	
<b>Issued on a day:</b>	<b>Signature:</b>

**7.5 Post guarantee service check report**

<b>Service center:</b>	
<b>Date of repair:</b>	
<b>User of actuator:</b>	<b>Actuator operating place :</b>
<b>Actuator type number:</b>	<b>Actuator production number:</b>
<b>Detected product fault:</b>	
<b>Used spare parts:</b>	
<b>Remarks:</b>	
<b>Issued on a day:</b>	<b>Signature:</b>

## **7.6 Commercial representation**

### **Slovak Republic:**

**Regada, s.r.o.,**  
Strojnícka 7,  
080 01 Prešov  
Tel.: +421 (0)51 7480 460,  
Fax: +421 (0)51 7732 096,  
E-mail: [regada@regada.sk](mailto:regada@regada.sk)

### **Czech republic:**

**REGADA Česká s.r.o. (Ltd.)** – exclusive representation REGADA, s.r.o. (Ltd.) for sale of electric actuators  
Kopaninská 109  
252 25 Ořech  
PRAHA – západ  
Tel.: +420 257 961 302  
Fax: +420 257 961 301