



INSTALLATION, SERVICE AND MAINTENANCE INSTRUCTIONS



Electric linear thrust actuator ST Mini

TEST CERTIFICATE

ELECTRIC LINEAR THRUST ACTUATOR ST Mini	
Type number 472.....	Power supply V Hz
Serial number	Max. load thrust N
Production year	Switching-off thrust N
Wiring diagram	Operating speed mm/min
.....	Stroke mm
Warranty period months	Transmitter
Serial number of electric motor	
Serial number of transmitter	
Tests made in accordance with 74 1002 00	
Tests made by	
Date	Signature and stamp

COMPLETENESS CERTIFICATE

Used valve	
Assembled by: Firm	
Name.....	
Warranty period months	
Date	Signature and stamp.....

INSTALLATION CERTIFICATE

Location	
Installed by: Firm	
Name	
Warranty period..... months	
Date	Signature and stamp.....

Please read these instructions carefully before mounting and operating the actuator!

Contents

1. General data	2
1.1 Purpose and applications	2
1.2 Safety instructions	2
1.3 Instructions for staff training.....	2
1.4 Warning for safety use.....	2
1.5 Warranty conditions.....	3
1.6 Under-guarantee and after-guarantee service.....	3
1.7 Operation conditions.....	4
1.8 Description.....	5
1.9 Basic specifications	7
1.10 Packing, transport, storing and unpacking	9
1.11 Appreciation of the product and packing.....	9
2. Installation and dismantling of actuator	10
2.1 Installation	10
2.2 Dismantling.....	12
3. Adjusting of actuator	13
3.1 Gear unit adjustment	13
3.2 Position unit adjustment (Fig. 5)	13
3.3 Adjustment of resistant transmitter	14
3.4 Adjustment of the Electronic Position Transmitter (EPV) - the Resistive Transmitter (Potentiometer) with the Converter PTK 1	14
4. Service, maintenance and troubleshooting	16
4.1 Service.....	16
4.2 Maintenance - extent and periodicity	17
5. Spare parts	17
6. Enclosures	18
6.1 Wiring diagrams.....	18
6.2 Dimensional drawings.....	19
6.3 Record on warranty service intervention.....	23
6.3 Record on after-warranty service intervention	24
6.4 Commercial agency and contractual service centers	25

1. General data

1.1 Purpose and applications

Electric part-turn actuators (hereinafter **EA**) of **ST MINI** (hereinafter **ST**) types are high-powered electric-mechanical products designed for direct installations onto controlled devices (regulating bodies -valves, etc.). EA of ST types are provided for remote control of closing bodies, and with external controller for automotive control of regulating bodies in both directions of their movement. They can be equipped with means of measuring and control of technological processes where an unified analogue direct current signal is an information bearer on their output. They can be used in heating, energy, gas, air-conditioning and other technological systems, which they are suitable for, regarding their features. They are connected with controlled devices with a flange, or using a pillar or flange.

Notes:



It is forbidden to use EA as a lifting mechanism!

Switching of actuator by a semiconductor switches have to be consulted with producer.

1.2 Safety instructions

Characteristics of the Product Regarding Its Exposure Rate



EA of ST MINI types are reserved technical devices with higher rate of danger, with possibility of installation in areas specially danger regarding casualties caused by electric current.

Electric actuators are according to directive LVD 2006/95/EC and standard IEC 61010-1 + A1 in terms of valid certificate, assigned for installation category II (overvoltage category), pollution degree 2.

Product influence to environment

Electromagnetic compatibility (EMC): the product complies with the requirements of the Directive 2014/30/EU of the European Parliament and of the Council on the approximation of the laws the Member States relating to the electromagnetic compatibility and with the requirements of standards as well EN IEC 61000-6-4, EN IEC 61000-6-2, EN IEC 61000-3-2 and EN 61000-3-3 + A1, in the edition in terms of valid certificate.

Vibrations caused by the product: product influence is negligible

Noise produced by the product: the maximum allowable noise level (A) of the product measured in a place of operation is 78 dB (A).

1.3 Instructions for staff training

Requirements for professional qualification of people performing installation, service and maintenance



The electrical connection of the actuator can only be carried out by a person in accordance with legislative requirements of the given country, depending on the required areas of location/use. Service can be performed only by workers professionally qualified and trained by the producer or contracted service centre

1.4 Warning for safety use



1. Products are assigned for operation in environment consist of gas, steam and vapours, with temperature range: -25°C to $+55^{\circ}\text{C}$, with pressure range from 0.8 to 1.1 bar.
2. If the actuator is placed on device which regulate medium with higher temperature than $+55^{\circ}\text{C}$, protect the actuator by additional construction in order to maintain ambient temperature max. $+55^{\circ}\text{C}$ and also to stop temperature transmitting through junction component!
3. Cable glands blinds are assigned only for transport and storage period, i.e. for period till the actuator is builded into operation, than blinds must be replace by connecting cable.

4. In case of not using one of the cable gland, it has to be replaced with a suitable blinding plug. Temperature at the point where the cables enter the actuator can reach max. 90°C. When choosing the connection cables for the actuator, it is therefore necessary to consider this temperature as well

Product protection

EA **ST MINI** does not have own short-circuit protection, therefore there must be included suitable protective device into the supply power (circuit breaker, or fuse), which serves at the same time as main switch.

Type of equipment from a connection point of view: The equipment is designed for permanent connection.

1.5 Warranty conditions

The supplier is responsible for completeness of the delivery and guarantees these specifications of the product which are stated in Technical conditions (TP) or specifications agreed in the Contract.

The supplier is not responsible for any deterioration of parameters caused by the customer during storage, unauthorised installation or improper operation.

1.6 Under-guarantee and after-guarantee service

Our customers are provided with professional service of our firm in installation, operation, service, maintenance, revision and help in troubleshooting for all our products.

Under-guarantee service is performed by the service department of the production plant, or by a contracted service centre according to a written claim.

In case of occurring of any fault please let us know it and state:

- basic data from nameplate: type code and serial number,
- type of fault - description of claimed fault (actuator employment), ambient parameters, (temperature, humidity...), duty cycle including frequency of switching, type of switching-off (position or thrust), set switching-off thrust),
- it is recommended to place also Installation certificate.

It is recommended to have **after-guarantee service** performed by the service department of the production plant, or by a contracted service centre.

1.6.1 Lifetime of actuators

The lifetime of an electric actuator (EA) is at least 6 years.

EA used for closing mode (closing valves) comply with the requirements for at least **15,000 working cycles** (cycle C – O – C: for linear EA).

EA used for regulating/modulating operation (control valves) comply with the below stated numbers of **operating hours** at the total number of 1 million start-ups:

Switching frequency				
max. 1,200 [h ⁻¹]	1,000 [h ⁻¹]	500 [h ⁻¹]	250 [h ⁻¹]	125 [h ⁻¹]
Minimal lifetime expectancy – number of operating hours				
850	1,000	2,000	4,000	8,000

Time of **net operation** is min. 200 hours, max. 2,000 hours.

Lifetime at operating hours depends on loading and switching frequency.

Note : High switching frequency does not ensure better regulation. Setting of regulation parameters should be therefore made with the inevitably necessary switching frequency needed for the process in question.

1.7 Operation conditions

1.7.1 Product location and operation position

- The assembly and operation of electric actuators in standard make can be on covered places of industrial objects without the regulation of temperature, humidity and with protection against direct exposure of climate influence (e.g. direct sun shine, precipitations, etc.).
- Electric actuators must be placed with access to cover of control box, to control box, to bushings.
- Installation and operation of actuators is possible in either position, while motor axis is in horizontal position. Common position is the one with vertical position of exit part axis and control box above.

1.7.2 Operation Environment

CLIMATE GROUPS AND TYPES

According to valid standard IEC 60 721-2-1, there are delivered these versions of electric actuators:

- 1) Version „**temperate**“ for climate temperate
- 2) Version „**tropical dry and dry**“ for type climate tropical dry and dry

In accordance with IEC 60 364-1, IEC 60 364-5-51 and IEC 60 364-5-55 within valid edition the EA have to resist external effects and operate reliably:

In the conditions of the following types of environment:

- mild to hot dry with temperature in range -25°C to $+55^{\circ}\text{C}$ **AA 7***
- with relative humidity 10 to 100 %, with occasional condensation, with max. contain of water 0,028 kg/kg of dry air, with temperatures stated above..... **AB 7***
- with height above sea level 2 000 m, with barometric pressure range 86 to 108 kPa **AC 1***
- with shallow dive – (product in protection IP x 7) **AD 7***
 - with submersion – (product with enclosure IPx8)..... **AD8***
- with medium level of dust content – with a possibility of effects of flame-proof, non-conducting and explosion-proof dust, medium cover of dust; dust fall more than 350 but at most 1000 mg/m² (products with protection enclosure of IP 6x)..... **AE 6***
- with atmospheric occurrence of corrosive and pollution media (with high degree of atmosphere corrosive aggressiveness); important presence of corrosive pollution **AF 2***
- with a possibility of influences of mechanical stress:
 - medium sinusoid vibrations with frequency in range 10 up to 150 Hz, with shift amplitude of 0,15 mm for $f < f_p$ and acceleration amplitude 9,8 m/s² for $f > f_p$; (transition frequency f_p is from 57 up to 62 Hz) **AH 2***
 - medium impacts, shocks and vibrations **AG 2***
- with serious danger of plants and moulds growing **AK 2***
- with serious danger of animals occurrence (insects, birds, small animals) **AL 2***
- with detrimental influence of radiation:
 - of stray current with intensity of magnetic field (direct and alternating of power supply frequency) to 400 A.m⁻¹ **AM 2***
 - of sun radiation with intensity > 500 a ≤ 700 W/m² **AN 2***
- with effects of medium seismic activity with acceleration > 300 Gal ≤ 600 Gal **AP 3***
- with indirect danger of storm activity **AQ 2***
- with fast moving of air and strong winds **AR 3 , AS 3***
- with persons frequent touching earth potential (persons often touch conductive parts or they stand on the conductive basement) **BC 3***
- without any danger media with object **BE 1***

*Marking in accordance with IEC 60364-1, IEC 60 364-5-51 and IEC 60 364-5-55 within valid edition

1.7.3 Power supply and duty cycle

Power supply:

electric motor	230 V AC ±10%, or 24 V AC ±10%
control	230 V AC ±10%, or 24 V AC ±10%
potentiometer	$\sqrt{P \times R}$ V AC/DC
electronic positional transmitter without power supply (2-wire)	15 up to 30 V DC
electronic positional transmitter without power supply (2-wire)	24 V DC ±20%

Power supply frequency 50 Hz or 60* Hz ± 2%

Note: At frequency of 60 Hz control speed is increased by 1.2 times.

Duty cycle (according to IEC 34-1, 8):

EA ST MINI are designed for **remote control**:

- short-time operation **S2-10 min**
- intermitted operation **S4-25%, 6 up to 90 cycles per hour**

EA ST MINI with external controller :

- intermitted operation **S4-25%, 90 up to 1200 cycles per hour**

Note:

EA ST MINI is possible to connect with an external controller and use it as regulated EA. The max. load thrust is 0,8 times the max. load thrust of ST MINI with remote control.

1.8 Description

The actuators are driven with an electric motor (1) fed and controlled through two thrust switches (2). The thrust switches are switched with a finger (5). The position switches (3) are switched with motion of the cams (4).

In case of blackout or damage of switches the actuator can be operated by manual control.

The actuators are controlled with connection of voltage to the corresponding actuator terminals. If the voltage is connected to the terminals 1 and 12 of the two-thrusts version (the thrust switches S1 and S2), or 1 and 20 ones in case of the one-thrust version (the position switch S3 and the thrust switch S2), the actuator output part performs linear motion in the direction „opening“. The motion in the direction „closing“ can be reached with connection of voltage to the terminals 1 and 16 or 1 and 24 according to the wiring diagram.

In accordance with the order the control part can also contain a position transmitter (6) functioning as a feedback or as a remote position transmitter. The remote position transmitter with the unified output signal consists of the resistive transmitter (6) and the electronics board (11). The transmitter rotation is derived from the output gear rack through the gear wheels system (7).

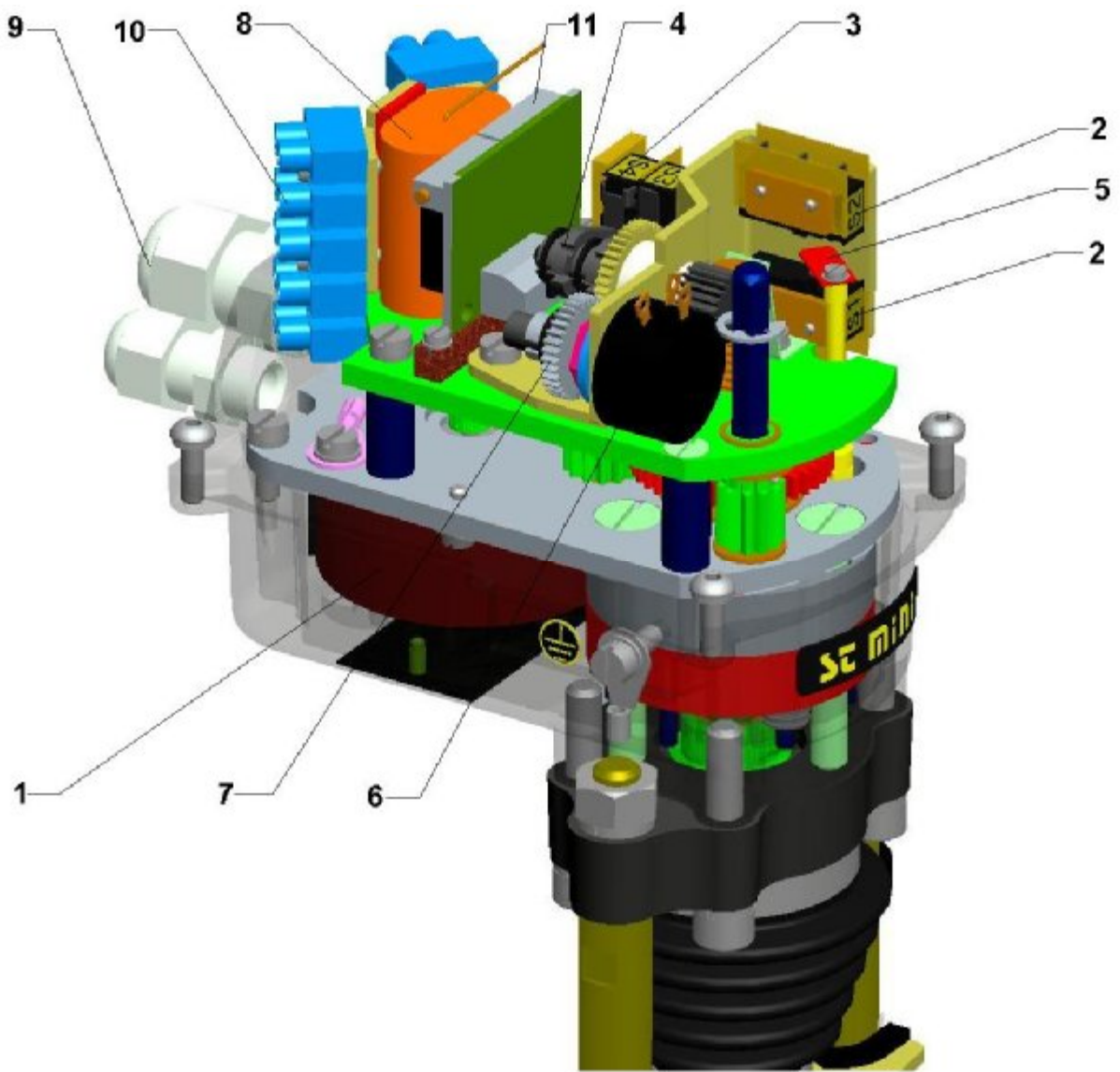

Fig.1

1.9 Basic specifications

1.9.1 Basic EA specifications:

Max. load thrust [N], switch-off thrust [N], operating speed [mm/min], operating stroke [mm] and electric motor parameters are given in Table 1.

Table 1: Basic Specifications

Type/ type number	Operating speed ±10[%]	Operating stroke ± 5mm		Max. load thrust	Switch-off Thrust ±10 [%]	Weight	Electric motor ¹⁾					
		without transmitter	with transmitter				Power supply nominal voltage	Nom. power	Nom. speed	Men. current	Capacitor capacity.	
	[mm/min]	[mm]	[mm]	[N]	[N]	[kg]		[V] ±10%	[W]	[1/min]	[A]	[µF/V]
1	2	3	4	6	7	8	9	10	11	12	13	14
ST MINI; type number 472	5	16; 25	6;7;8; 10; 12,5; 16; 20; 25	220	250	cca 1,9	Single-phase	230, or (24)	2,75	375	0,04 (0.4)	0.27 (25)
				440	480							
				630	700							
				830	920							
				1000	1100							
	7.5			220	250							
				440	480							
				630	700							
				830	920							
				1000	1100							
	10			220	250							
				440	480							
				630	700							
				830	920							
				1000	1100							
	15			220	250							
				440	480							
				630	700							
				830	920							
				1000	1100							
	30			220	250							
				440	480							
				630	700							
				830	920							
				1000	1100							
	40			220	250							
				440	480							
				630	700							

1) Switching elements for different type of load (also for EA) defines standard EN 60 947-4-1.

Additional technical data:

EA protection enclosure: **IP 67, IP 68** (EN 60 529)

According to definition for EA, enclosure IP68 fulfills following requirements:

- water column max. 10m
- time of continuous submersion in water max. 96 hours.

Mechanical ruggedness:

sinusoid vibrations with frequency in range from 10 up to 150 Hz,
 with shift amplitude of 0.075 mm for $f < f_p$
 with acceleration amplitude of 9.8 m/s^2 for $f > f_p$
 (transition frequency f_p is from 57 up to 62 Hz)

drop resistance: 300 drops with acceleration 5 m.s^{-2}
 seismic resistance: amplitude of the shock off 6 on Richter scale

Self-locking: guaranteed within 0% till 100% load thrust

Position transmitters

Resistive – potentiometer

Resistance single (B1): $100 \Omega, 2000 \Omega$
 Operating life of transmitter $1 \cdot 10^6$ cycles
 Load capacity: $0.5 \text{ W up to } 40^\circ\text{C}$ ($0 \text{ W}/125^\circ\text{C}$)
 Maximum current of sliding contact max. 35 mA
 Maximum supply voltage: $\sqrt{P \times R} \text{ V DC/AC}$
 Potentiometer linearity error: $\pm 2 [\%]^1$
 Potentiometer hysteresis: max. $1.5 [\%]^1$
 Output signal values measured on clamps 71 and 73 at limit positions
 For ST: "O" (open) $\geq 93\%$, "Z" (closed) $\leq 5\%$

Electronic positional transmitter (EPV) - converter R/I (B3)

2-wire version reyp. 3-wire version (without built-in power supply)

Current signal (2-wire version) $4 \div 20 \text{ mA (DC)}$
 Current signal (3-wire version) $0 \div 5 \text{ mA (DC)}$
 $0 \div 20 \text{ mA (DC)}$
 $4 \div 20 \text{ mA (DC)}$
 $0 \div 10 \text{ V (DC)}$
 Power supply voltage (2-wire version) $15 \div 30 \text{ V DC}$
 Power supply voltage (3-wire version) $24 \text{ V DC } \pm 20\%$
 Load resistance for 2-wire version – converter $4\text{-}20 \text{ mA}$ max. $R_L = (U_n - 9\text{V}) / 0,02\text{A} [\Omega]$
 (U_n - power supply voltage [V])
 Load resistance for 3-wire version – converter $0\text{-}5 \text{ mA}$ max. $3\text{k}\Omega$
 Load resistance for 3-wire version – converter $0 - 20 \text{ mA}, 4 - 20 \text{ mA}$ max. 750Ω
 Load resistance for 3-wire version – converter $0 - 10 \text{ V}$ min. $10 \text{ k}\Omega$
 Temperature dependency max. $0,020 \text{ mA} / 10 \text{ K}$
 Output signal values at limit positions: "O" $20 \text{ mA (5mA, resp. } 10 \text{ V)}$ (clamps 81,82)
 "Z" $4 \text{ mA (0 mA, resp. } 0 \text{ V)}$ (clamps 81,82)
 Values tolerance of output signal of EPV "Z" $+0,2 \text{ mA}$
 "O" $\pm 0,1 \text{ mA}$
 EPV transmitter linearity error: $\pm 2 [\%]^1$
 EPV transmitter hysteresis: max. $1.5 [\%]^1$

¹⁾ from rated value of transmitter referred to output values

Switching-off:

switching-off voltage: 250 V(AC) ; 2 A ; $\cos \varphi = 0,8$, $0,1 \text{ A} - 250 \text{ V(DC)}$, resp.: 24 V (DC) ; 2 A ; $T=L/R=3\text{ms}$
 min. switching voltage 20 V
 min. switching current 100 mA
 switching time max. 20 ms
 insulation resistance $50 \text{ M}\Omega$

Manual control: with box spanner

Output part backlash: max. $0,25 \text{ mm}$ (at 5% of max. load thrust)

Adjustment of limit positions:

Position switch S3 or S4 is adjusted to specified stroke.

Limit position switches are adjusted with accuracy $\pm 0,5 \text{ mm}$ referring to lower position and stroke.

Setting of thrust switches

Power thrust switches have not been set.

1.9.2 Mechanical connection:

- flange
- pillars

Basic and connecting dimensions are given in dimensional drawings

1.9.3 Electric connection

to terminal board (X): max. 10 terminals, connecting cable size max. 1.5 mm²

2 cable bushings – 1 x cable diameter from 5 to 10 mm, 1 x cable diameter from 4 to 7 mm

protection terminal: external and internal, mutually connected and marked with protection earthing mark

Electric connection - according to wiring diagrams.

Attention!



Product is in protection IP67. For sufficient protection-safety is necessary consistently fix the top cover of the actuator as well as keeping of the cable diameter and its attachment in the cable bushings. After an immersion is recommended to remove top cover and check if water has got into the actuator. In case of water penetration into the actuator is needed to dry internal parts before renew the operation.

1.10 Packing, transport, storing and unpacking

The EA ST is delivered in solid packages guaranteeing resistance in accordance with IEC 60 654-1 and IEC 60 654-3.

After receiving EA check whether during transport or storage the actuator was not damaged. Compare also whether the parameters on their nameplates are in accordance with accompanying documentation or the Contract. If any discrepancy or fault occur inform immediately your supplier.

If the actuators and accessories are not immediately installed, they have to be stored in dry, well-ventilated sheltered rooms, protected against dirt, dust, soil humidity (with placing onto shelves or onto pallets), chemical impacts and encroachment, at ambient temperature from -10°C up to +50 °C and relative humidity max. 80 %.



It is not allowed to store EA in the open air or in areas not protected against direct impact of climate!

1.11 Appreciation of the product and packing

The product and its package are made of recycling materials. Do not throw the single parts of the package and of the product after their life but sort them according to instructions in corresponding executives or regulations of environment protection, and allow their recycling.

The product and its packing are not a source of any environment pollution or contamination and do not contain any dangerous waste.

2. Installation and dismantling of actuator



Note:

Check again if installation of EA is according to Chapter 1.5 Operation conditions. In case that installation and operation conditions are different from recommended the consultation with producer is needed.

Before starting of mounting the EA onto the valve:

- Check again whether the EA was not damaged during storing.
- Check whether the adjusted operating stroke and connecting dimensions of the actuator (see the nameplate) are in compliance with the valve parameters.
- In case of inconsonance, perform adjusting according to the part Adjustment.

2.1 Installation

EA is by the producer adjusted to parameters according to the nameplate, with connecting dimensions according to the corresponding dimensional drawing and put it to a mid-position.

2.1.1 Mechanical connection

The actuators can be installed and operated in any position. For horizontal position must be electric actuator placed in a way, that columns are above each other.

While installing leave enough space for dismantling of the upper cover to allow adjusting of the control parts.

Caution: Once the lower surface is exceeded behind that marked by the indicator, the electric actuator screw and nut will experience mechanical disconnection, i.e., its inactivation.

Mechanical connection for pillar version - Fig. 3

- Connection procedure: Check the label whether valve and actuator strokes are the same.
- The valve (B) is put to the position „closed“ and the actuator (A) to a mid-position.
- Loosen the nuts (4) on the pillars (6).Screw the pillars (6) with the cross system into the valve flange (13).
- Tighten the pillars nuts (4).
- Unscrew the coupling (3) screws (7) to dismantle the coupling into parts.
- Screw the coupling (3) nut onto the valve shaft (10) to reach the connecting size L in accordance with the table and the actuator nameplate.
- Unscrew the coupling (3) nut by one revolution and lock it by a nut (12).
- tighten the coupler screws (7).

- A electric actuator
 3 coupling nut
 4 pillar nut
 6 pillar
 7 coupling screw
 B valve
 10 valve shaft
 12 locking nut
 13 valve flange

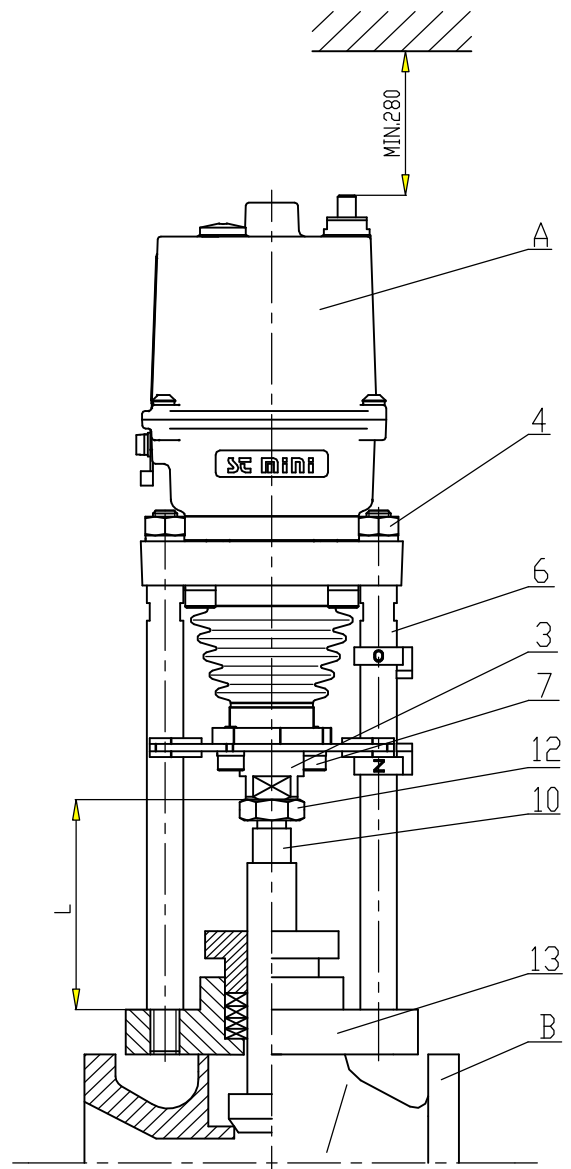

Fig.3

Mechanical connection for versions with flange (Fig. 4)

Connection procedure:

- Check the label whether valve and actuator strokes are the same.
- The valve (B) is put to the position „closed“ and the actuator (A) to a mid-position.
- Place the actuator (A) onto the valve (B).
- Unscrew the coupling (3) screws to dismantle the coupling into parts.
- Screw the coupling (3) nut onto the valve shaft (10) to connect flanges (13) and (5).
- Tighten the central nut (11), or the screws in the actuator`s flange (depends on the connecting version), to connect flanges (13) and (5).
- Check the connecting size L between the coupling and flange (13) in accordance with the table and the actuator nameplate.
- Unscrew the coupling (3) nut by one revolution and lock it by a nut (12) to create the prestress onto the valve seat.
- tighten the coupler screws (7).

A	electric actuator
3	coupling nut
4	pillar nut
5	actuator flange
6	pillar
B	valve
10	valve shaft
11	central nut
12	locking nut
13.....	valve flange

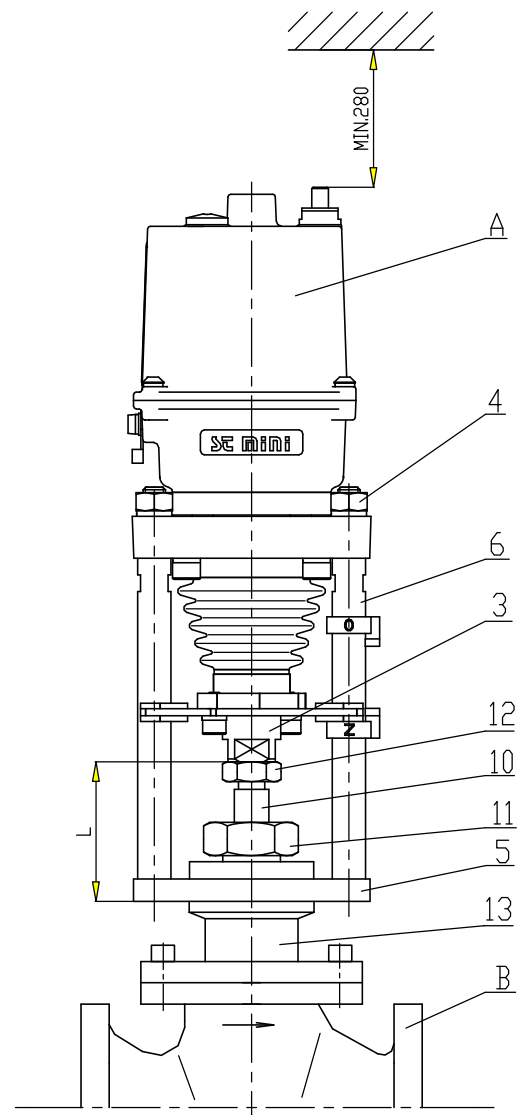

Fig.4

2.1.2 Electric connection and checking of function

1. Follow instructions in the part "Requirements for professional qualification"!

2. While laying electrical line abide by the instructions for heavy current installations.

3. Cables to terminal board lead through screw bushings.

4. Before initiation ES into operation internal and external protection terminals are needed to be connected.

5. Feeding cables are to be fixed to the solid construction at most 150 mm from the bushings.

6. It is recommended to use screened cables to connect remote transmitters.



Connecting with the master system:

The EA can be controlled with an external position controller.

1. If the EA is controlled with an external controller using unified signal from a two-wire transmitter (capacitive or resistive with a converter in two-wire connection), it is needed to arrange connecting of the two-wire transmitter loop to electrical earth of the successive external controller!

2. Connection can be performed only in one point, in any part of loop out of the EA.

3. Electronics of the two-wire transmitters is galvanically insulated that is why it can serve as an external source for supplying of several transmitters (their number depends on current which the source can supply).



The actuator is connected in accordance with the wiring diagrams put into the actuator upper

cover. Electric connection is made through bushings (9) to the terminal board (10), fig.1, with max.10 terminals with connecting cable size max. 1.5 mm². The installed set of capacitors (8) allows starting of the actuator.

Notes:

1. The EA are delivered with bushings, which in case of tight putting on the leads assure protection enclosure up to IP 68. For required protection enclosure it is needed to use rings according to the actual cable diameter.
2. While fixing the cable it is needed to count with allowed bend radius to avoid damaging or deformation of the sealing element of the bushing. The leads are to be fixed with the solid construction at most 150 mm from the bushings.
3. It is recommended to use screened cables to connect remote transmitters.
4. The face areas of the control part cover have to be before re-mounting clean, coated with a grease without any acid (e.g. vaseline) and sealing not damaged to avoid joint corrosion.
5. Reversion of the EA is sure, if the period between switching-off and switching-on of power supply for the reversed movement of the output part is minimally 50 ms.
6. Delay after switching-off, i.e. time since a reaction of switches till the motor is dead can be maximally 20 ms.
7. It is recommended to have the corresponding direction protection switched-off directly with the corresponding position or thrust switches.



Abide by instructions of valve producers, whether switching-off in limit positions is to be realised with position or thrust switches!

After electric connection it is recommended:

Check of wiring. Set the actuator into a mid-position. Check the right direction of output shaft movement with pressing the button "closing" (on the control board) and the stem should move out from the actuator. If not change the order of the mains phases.

Check the control unit switches wiring with switching consequently the contacts of the proper switches by pressing the control elements during the motion of the actuator (at proper connection) to the chosen direction. In case of correct wiring of the switches, the actuator stops or indicates the set position according to switching of the chosen switch. If any of the functions is fault check wiring of the switches according to the wiring diagram.



Abide by safety measures!

2.2 Dismantling



**Before dismantling it is required to disconnect the EA from mains!
Do not connect and disconnect live connectors!**

- Disconnect the EA from mains phases.
- Disconnect the leads from the EA terminal boards and loosen the cables from bushings.
- Loosen the fixing screws of the EA flange and of the coupling and disconnect the EA from the valve.
- While sending the EA to be repaired put it into a package solid enough to avoid damages of the EA during transportation.

3. Adjusting of actuator



Attention! See chapter 1.2. Safety instructions

**Disconnect the electrical electric actuator from electrical power network!
Observe safety regulations!**

EA is by the producer adjusted to parameters according to the nameplate.

The adjustment can be performed at a mechanically and electrically connected EA. This part describes adjustment of EA to specified parameters in case that any unit of EA is reset.

Laying of adjusters of the control board is shown on Fig.1.

3.1 Gear unit adjustment

The switching thrust values both for the direction „opening“ (the thrust switch S1) and for the direction „closing“ (the thrust switch S2) are in the production plant adjusted to the rated thrust with tolerance $\pm 10\%$. The numeric values are given in the corresponding specification table. Adjustment and resetting of the gear unit to other thrust values are not possible.

3.2 Position unit adjustment (Fig. 5)

The position switches are to be adjusted with setting the cams switching them. Turning the cam is performed with a screwdriver put into the cam groove.

3.2.1 Adjustment of the S3 limit switch

In case of the one-thrust wiring of the actuator the electric motor is during the actuator motion in the direction „opening“ fed through the S3 position switch. If it is out of tune follow these steps:

- Put the actuator and the controlled device to the required position „open“.
- Turn the cam switching the switch S3 clockwise until the switch S3 switches.

3.2.2 Adjustment of the S4 limit switch

When EA is equipped by the S4 position switch for position “closed” and if it is out of tune follow these steps:

- Put the actuator and the controlled device to the required position „closed“.
- Turn the cam switching the switch S4 counter clockwise until the switch S4 switches.

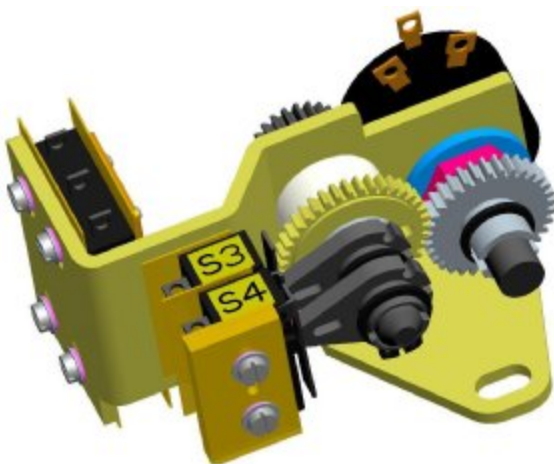

S3 – position switch "open"
S4 – position switch "closed"

Fig.5

3.3 Adjustment of resistant transmitter

The **resistant transmitter** is in the EA **ST** used to function as a remote position indicator. Before the resistant transmitter adjustment the position switches have to be adjusted.

The potentiometer is not needed to be adjusted, it is able to adjust itself with putting the actuator to the both limit positions in accordance with the stroke specified on the nameplate.

Notes:

1. If the actuator was adjusted to another stroke the transmitter resistance in the limit positions should not correspond with the technical parameters given in the chapter 1.7.
2. In case that the EA is not used in the whole stroke range given on the nameplate, the resistance in the limit position "open" is proportionally reduced.

3.4 Adjustment of the Electronic Position Transmitter (EPV) - the Resistive Transmitter (Potentiometer) with the Converter PTK 1

3.4.1 EPV – the 2-wire version (Fig. 6)

The position transmitter with the converter PTK1 is in the plant adjusted to have the output current signal on the terminals 81-82 (the wiring diagram Z23) as follows:

in the position "open" 20 mA
 in the position "closed"4 mA

If the transmitter requires a new adjustment follow these steps:

- Put the actuator to the position "closed" and switch the power supply off.
- Adjust the resistive transmitter according to the previous chapter. The resistance is to be metered on the terminals R-R (Fig. 6). The used transmitter resistance is 100 Ω.
- Switch the converter's power supply on.
- Turn the adjusting trimmer A (Fig. 6) to adjust the output current signal rate measured on the terminals 81-82 to 4 mA.
- Set the actuator to the position "open".
- Turn the adjusting trimmer B (Fig. 6) to adjust the output current signal rate measured on the terminals 81-82 to 20 mA.
- Check the output signal of the converter in the both limit positions, and repeat the procedure if needed.

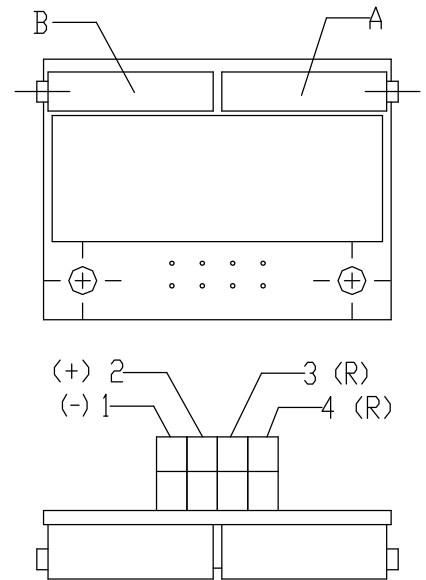

Fig.6

Note:

The output signal of 4-20mA can be adjusted at the range from 75 up to 100% of the rated stroke stated on the actuator's nameplate. At values less than 75% the value 20 mA is reduced proportionally.

3.4.2 EPV – 3-wire version (Fig. 7)

The resistive transmitter with the converter is in the plant adjusted to have the output current signal metered on the terminals 81-82 (the wiring diagram Z257 - without power supply) as follows:

- in the position „open“20 mA or 5 mA, resp. 0 V
- in the position „closed“0 mA or 4 mA, resp. 10 V according to the specified version of the converter.

If the transmitter requires a new adjustment follow these steps:

- Put the actuator to the position „closed“ and switch the power supply off.
- Adjust the resistive transmitter according to the previous chapter. The resistance is to be metered on the terminals 0%-100% (Fig. 7). The used transmitter resistance is 2000W or 100 W.

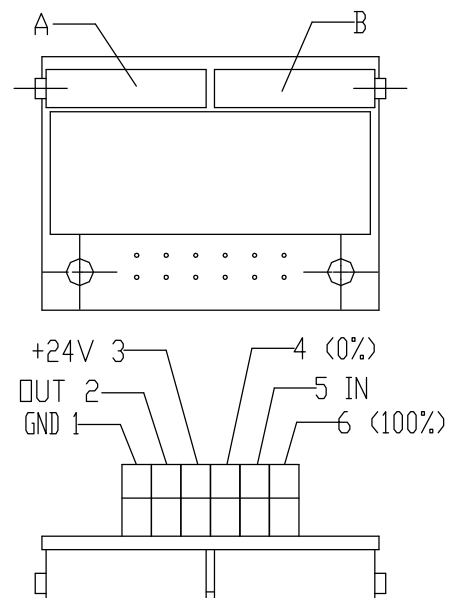

Fig.7

- Switch the converter's power supply on. Turn the adjusting trimmer A (Fig. 7) to adjust the output current signal rate measured on the terminals 81-82.
- Set the actuator to the position „open“.
- Turn the adjusting trimmer B (Fig. 7) to adjust the output current signal rate measured on the terminals 81-82.
- Check the output signal of the converter in the both limit positions, and repeat the procedure if needed.

Note:

The output signal of (0-20mA, 4-20mA or 0-5mA, 0-10V - according to the specification) can be adjusted at the range from 85 up to 100% of the rated stroke stated on the actuator's nameplate. At values less than 85% the value of the output signal is reduced proportionally.

Note:

The output signal of 4-20mA can be adjusted at the range from 75 up to 100% of the rated stroke stated on the actuator's nameplate. At values less than 75% the value 20mA is reduced proportionally.

4. Service, maintenance and troubleshooting

4.1 Service



1. In general it is provided that service of the EA is performed by a qualified worker in accordance with requirement given in Chapter 1!
2. After putting the EA into operation it is needed to verify whether during manipulation any scratch on surface occurred, it is to be removed to prevent actuator against corrosion!

The EA requires just negligible service. Proper putting into operation is a recondition of reliable operation.

The service of the EA leads from the operation conditions and usually resides in information processing for further arranging of required functions.

The staff has to perform prescribed maintenance to prevent the EA during operation against impacts of environment, which exceed the frame of allowed influences.

Manual control

If needed (during adjusting, function checking, failure etc.) the staff can change setting of the controlled body using the handle follow these steps:

- Switch off the power supply
- Take off the top cover
- Push the button of manual disengagement (14) and hold it.
- Slip box spanner 6 (included in delivery) over the manual control shaft (13) and rotate the spanner counter-clockwise while pressing the manual control push-button. The valve will set to the "Open" position. After setting the actuator to required position, return button of the manual disengagement to the origin position what engages the gears.¹⁾
- Take off the handle and cover the actuator.

¹⁾ In case the button of manual disengagement do not get back to the position of motoric operation is necessary to turn with the handle to put the gear into mesh.

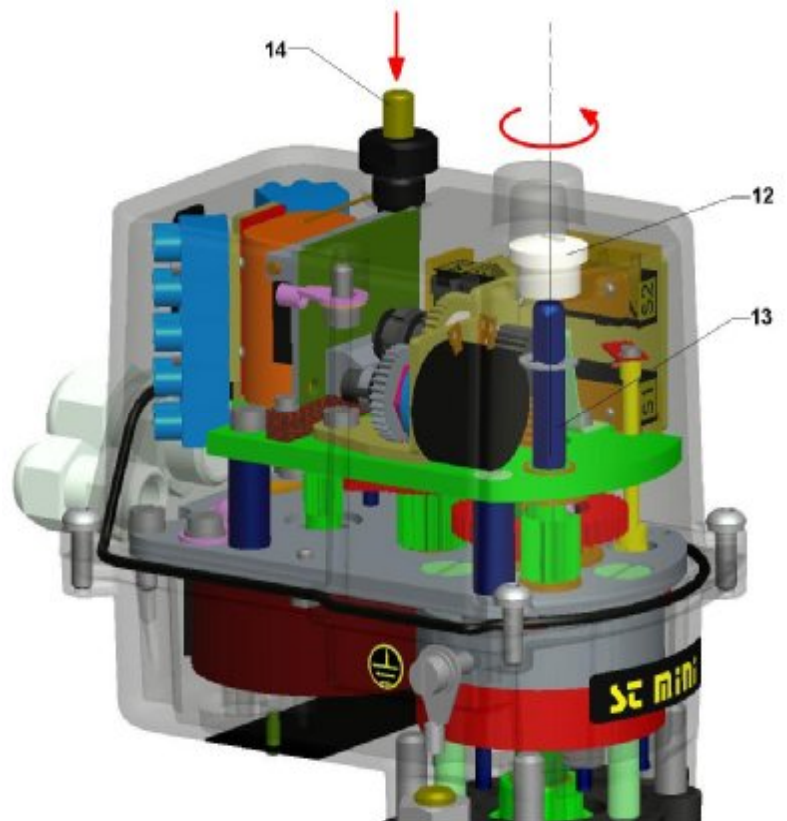

Fig.8

4.2 Maintenance - extent and periodicity

All screws and nuts affecting tightness and protection (IP) must be tightened during the inspection and maintenance. Similarly, once a year should be checked and if necessary tighten mounting screws of the terminal wires and assuring of the slip-on joints with wires.

The interval between two preventive inspections is four years.

In case of damage or after 6 years of the actuator's operation the replacement of cover seals and oil filling seals must be done.

The grease in the supplied actuators is designed for the lifetime of the product. It is not necessary to change the grease during the operation of the actuator.

Lubrication:

- gear part - in versions for climate – grease HF 401/0 (GLEIT- μ) resp. GLEITMO 585 K
- linear adapter – grease GLEIT- μ - HP 520M



Lubrication of the valve stem is independent on maintenance of the EA!

After every potential flooding of the product check, whether there is no water inside. After eventual water penetration, dry the product before repeated putting into operation and replace damaged sealings, resp. other parts of EA. identically check also tightness of cable bushings and replace them, if they are damaged.

- Every six months it is recommended to perform one check move in frame of adjusted operation stroke to verify reliability of functioning with setting back to the original position.
- If the audit rules do not determine else the inspection of EA is performed ones a year and tightening of all connecting and grounded screws have to be checked to avoid overheating.
- After 6 months from putting of EA into operation and once a year it is recommended to check tightening of fixing screws between the EA and the valve. (Tighten the screws with the cross system.)
 - While connecting and disconnecting of the EA check the tightness of cable glands – those with damaged sealings should be replaced by new ones of the approved type!
 - Keep the EA clean and take care about removing impurities and dust. The cleaning has to be performed regularly according to the operation possibilities and requirements.



5. Spare parts

Table No.2 Spare part list:

Spare part	Order Nr.	Position	Figure
Electric motor; 2.75 W; 230 V AC	63 592 382	1	1
Micro switch CHERRY DB 6G A1BA	64 051 447	2	1
Micro switch CHERRY DB 6G A1LB	64 051 466	3	1
Resistant wire transmitter (potentiometer) RP19; 1x100	64 051 812	6	1
Resistant wire transmitter (potentiometer) RP19; 1x2000	64 051 827	6	1

Warning: By supplying spare parts, the manufacturer is not responsible for damages caused by their disassembly and assembly. Installation, replacement of spare parts must be performed by authorized, qualified personnel

6. Enclosures

6.1 Wiring diagrams

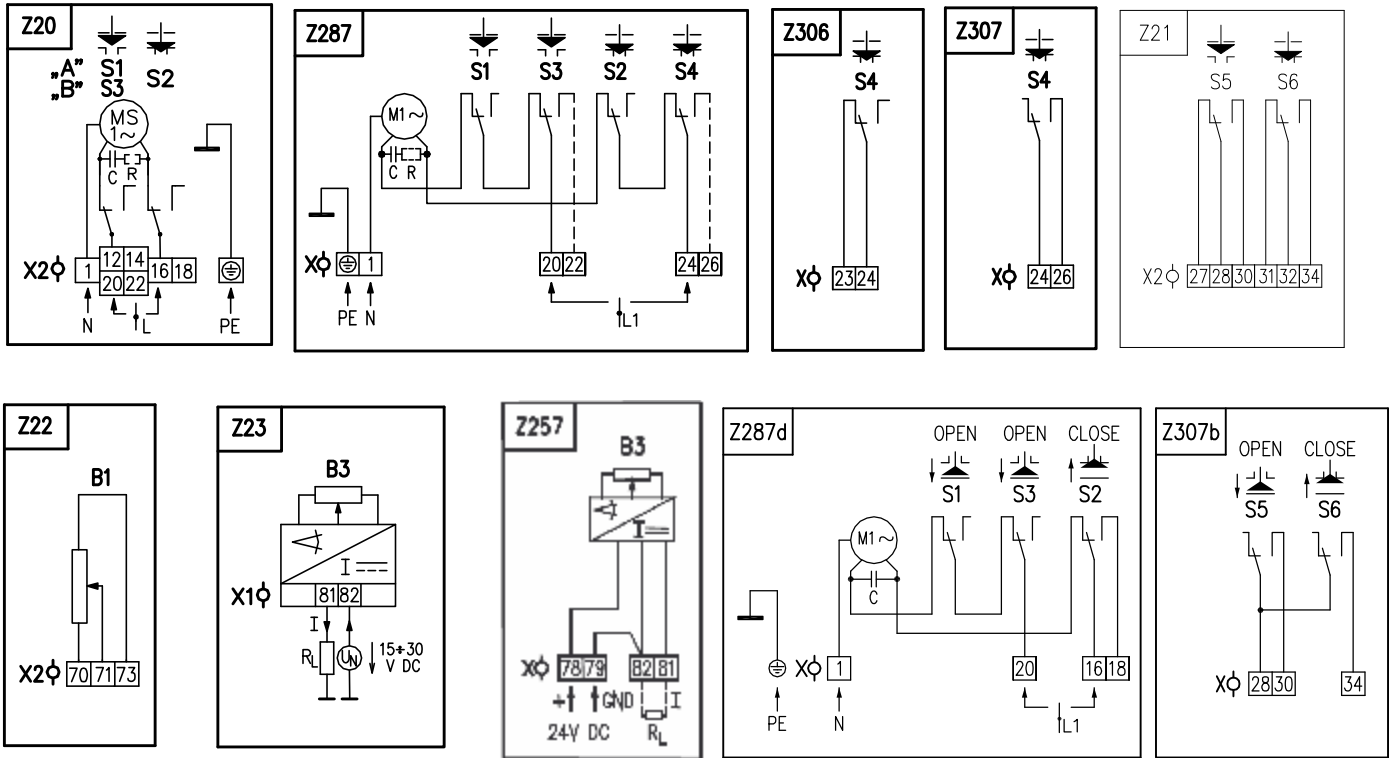

Legend:

- Z20 electric motor connection: "A" - with 1 thrust switch and 1 position switch; "B" – with 2 position switches
- Z21, Z307b additional position switches connection
- Z22 single resistant transmitter connection
- Z23 2-wire version of EPV – without power supply connection
- Z257 connection of resistive transmitter with current converter – 3 - wire – without power supply
- Z287, Z287d.... electric motor with a thrust and position switches connection
- Z306..... position switch connection – normally closed contact
- Z307 position switch connection – clamping contact

- | | |
|--|--------------------------------------|
| B1..... remote transmitter-resistive, single | R _L load resistance |
| B3 electronic position transmitter (EPV) | S1 thrust switch "open" |
| C..... capacitor | S2 thrust switch "closed" |
| I output current signal | S3 positional switch "open" |
| MS, M1 electric motor | S4 positional switch "closed" |
| R resistor | X, X1, X2.... terminal board |

Notes:

1. For the version of the actuator with positional switches (S3, S4) or with a transmitter, contacts drawn in dotted line are not leaded to terminal board. Wiring connection is limited by max. number of clamps 10.
2. At version ES with feeding voltage 24 V AC is not needed to connect ground wire PE.

6.2 Dimensional drawings

P-1476

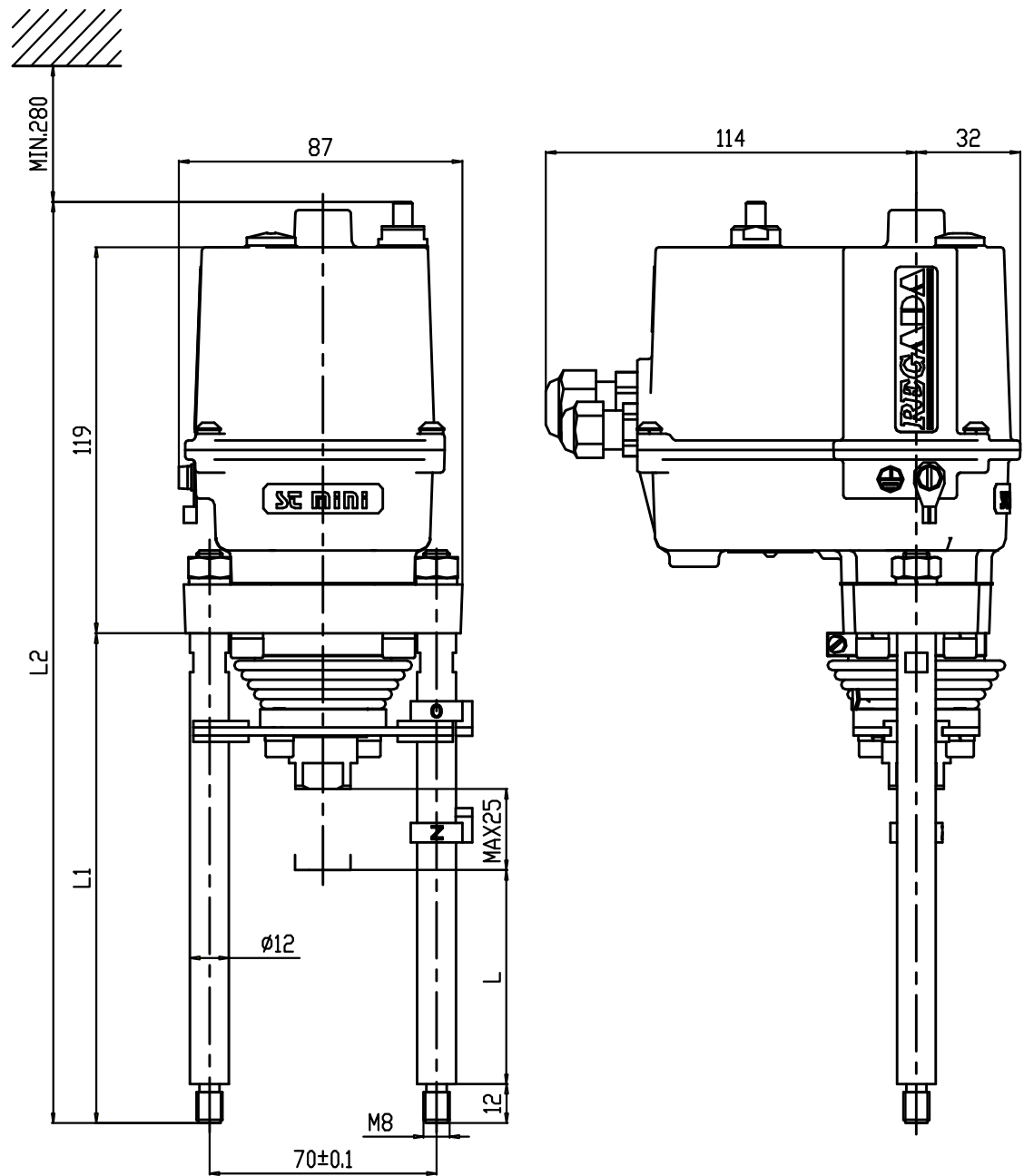

P-1476/B	92.5	177.5	310.5
P-1476/A	66	151	284
VYHOTOVENIE /VERSION/	L	L1	L2

P-1477

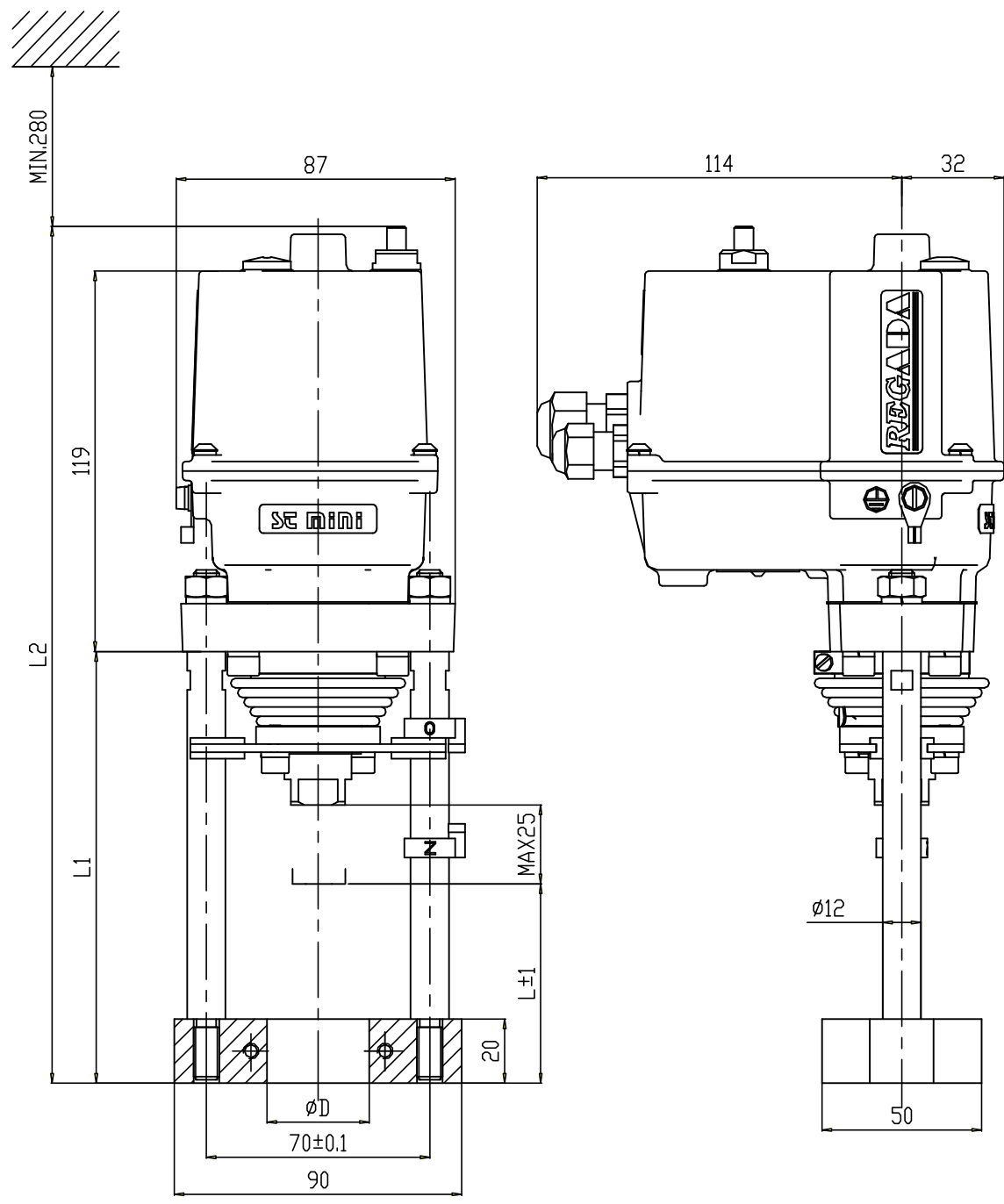

P-1477/B	∅40H9	66	139	272
P-1477/A	∅32H9	62	135	268
VYHOTOVENIE /VERSION/	∅D	L	L1	L2

P-1478

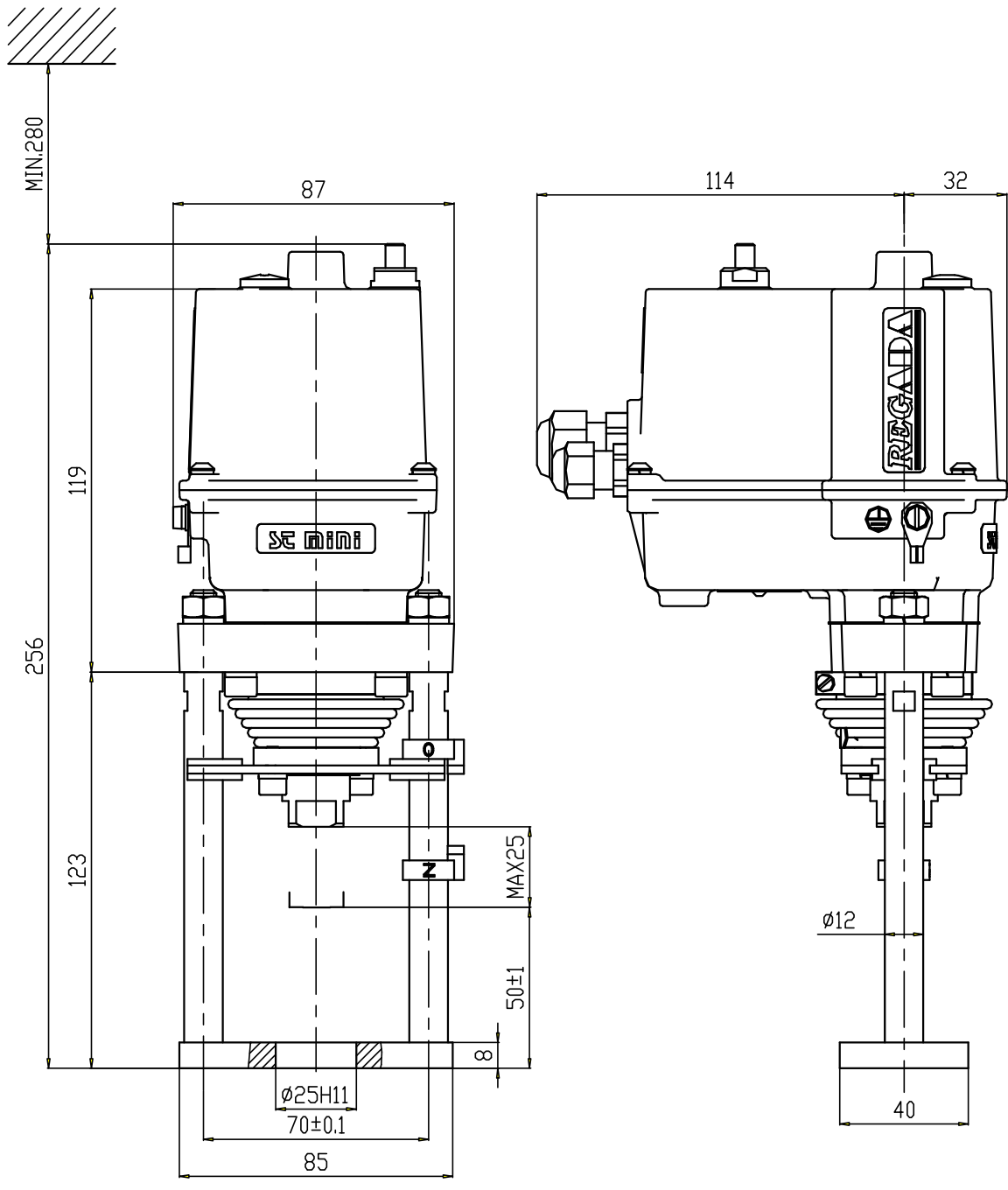

P-1479

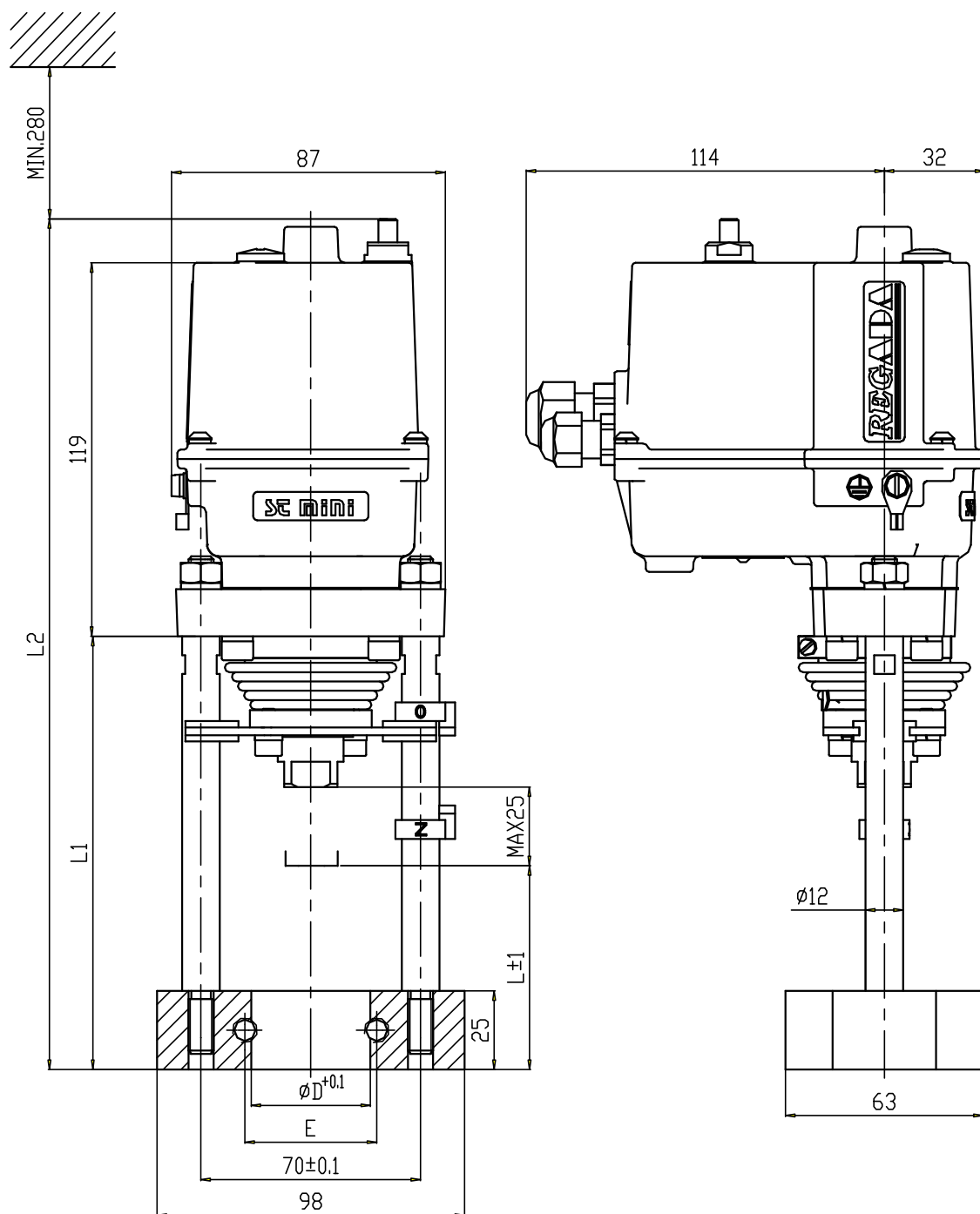

P-1479/B	∅35	40 ⁰ _{-0.1}	69	142	275
P-1479/A	∅38	42 ⁰ _{-0.2}	65	138	271
VYHOTOVENIE /VERSION/	∅D	E	L	L1	L2

6.3 Record on warranty service intervention

Service center:	
Intervention date:	Warranty repair No.:
Electric actuator user:	Complaint submitted by:
EA type No.:	EA serial number:
Complaint object:	Detected fault:
Applied spare parts:	
Notes:	
Made on:	Signature:

6.3 Record on after-warranty service intervention

Service center:	
Intervention date:	Warranty repair No.:
Electric actuator user:	Complaint submitted by:
EA type No.:	EA serial number:
Complaint object:	Detected fault:
Applied spare parts:	
Notes:	
Made on:	Signature:

6.4 Commercial agency and contractual service centers

Slovak Republic:

Regada, s.r.o.,
Strojnícka 7
080 01 Prešov
Tel.: +421 (0)51 7480 460
Fax: +421 (0)51 7732 096
E-mail: regada@regada.sk

Czech Republic:

Regada Česká, s.r.o.
Kopaninská 109
252 25 Ořech
PRAHA – západ
Tel.: +420 257 961 302
Fax: +420 257 961 301