

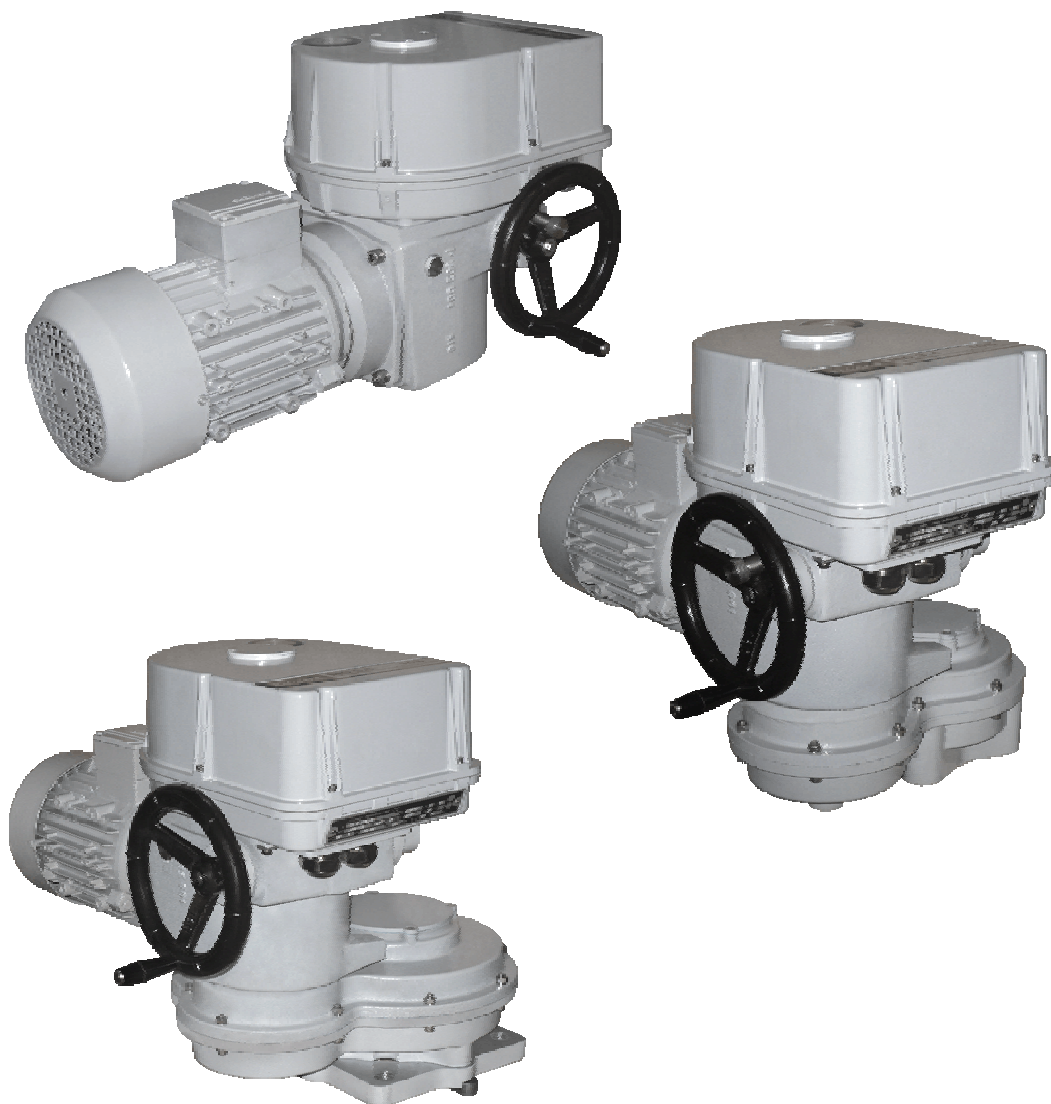

INSTALLATION, SERVICE AND MAINTENANCE INSTRUCTIONS



Electric multi-turn actuators UM 2

TEST CERTIFICATE

ELECTRIC MULTI – TURN ACTUATOR UM 2

Type number Power supplyVHz
Serial number Set switch-off torque Nm
Production year Operating speed min⁻¹
Wiring diagram Adjusted number of revolutions
Warranty period months Transmitter.....
..... Input operating signal
Serial number of electric motor
Serial number of transmitter
Serial number of controller

Tests made in accordance with TP 74 1042 00

Tests made by Packed by
Date Signature and stamp

COMPLETENESS CERTIFICATE

Used valve
Assembled by: Firm
Name
Warranty period months
Date Signature and stamp

INSTALLATION CERTIFICATE

Location
Installed by: Firm
Name
Warranty period..... months
Date Signature and stamp

Please read these instructions carefully before mounting and operating the actuator!

Contents

1. General data	2
1.1 Purpose and applications	2
1.2 Safety instructions	2
1.3 Data specified on electric actuator	3
1.4 Instructions for staff training	3
1.5 Warranty conditions	3
1.6 Under-guarantee and after-guarantee service	4
1.7 Operation conditions	4
1.8 Packing, transport, storing and unpacking	6
1.9 Assessment of the product and packaging and removal of contamination	7
2. Description, function and specifications	7
2.1 Description and function	7
2.2 Basic specifications	10
3. Installation and dismantling of actuator	16
3.1 Installation	16
3.2 Dismantling	19
4. Adjustment	20
4.1 Adjustment of the torque unit	20
4.2 Adjustment of position-signalling unit (S3(S13),S4(S14)) (Fig.6)	21
4.3 Signaling switches adjustment (S5,S6) (Fig. 8)	24
4.4 Position indicator adjustment (Fig.8)	24
4.5 Adjustment of resistant transmitter (Fig.9)	25
4.6 Adjustment of the Electronic Position Transmitter (EPV) - the Resistive Transmitter (Potentiometer) with the Converter PTK 1	26
4.7 Adjustment of Capacitive Transmitter CPT1/A (Fig.12)	27
4.8 Adjustment of the DCPT3M transmitter	28
4.9 Adjustment of position controller (Fig. 14)	31
4.10 Electric local control (Fig.15)	33
5. Service and Maintenance	34
5.1 Service	34
5.2 Maintenance - extent and periodicity	34
5.3 Troubleshooting	35
6. Accessories and Spare Parts	36
6.1 List of the Spare Parts	36
7. Enclosures	37
7.1 Wiring diagrams UM 2	37
7.2 Operation Logic Diagram of switches and relays	42
7.3 Dimensional drawings	43
7.4 Guarantee service check report	45
7.5 Post guarantee service check report	46
7.6 Commercial representation	47

The Installation, Service and Maintenance Instructions are drawn up according to requirements of EC Executive Nr. 89/392/EEC "Uniform requirements for machines and devices from the point of view of safety and health care", to save life and health of users and to avoid material damages and exposure environment to danger.

1. General data

1.1 Purpose and applications

Electric part-turn actuators (hereinafter **EA**) types **UM 2** designed for direct installations onto controlled devices (regulating bodies -valves, etc.). EA of **UM 2** types are provided for remote control in both directions of their movement. They can be equipped with means of measuring and control of technological processes where an unified analogue direct current or voltage signal is an information bearer on their input and/or output. They can be used in heating, energy, gas, air-conditioning and other technological systems, which they are suitable for, regarding their features. They are assembled by means of flange and connecting component in accordance with ISO 5210.



1. **It is forbidden to use EA as a lifting mechanism!**
2. **Switching of actuator by a semiconductor switches have to be consulted with producer.**

1.2 Safety instructions

Product characteristics from risk point of view



EA are reserved technical devices with higher rate of danger (group A), with possibility of installation in areas specially danger regarding casualties caused by electric current.

Electric actuators are according to directive LVD 2014/35/EU and standard EN 61010-1 within valid edition assigned for installation category II (overvoltage category), pollution degree 2.

The product meets the essential safety requirements according to EN 60204-1 and is in compliance with EN 55011/A1 within valid edition.

Product influence to environment

Electromagnetic compatibility (EMC): the product complies with the requirements of the Directive 2014/30/EU of the European Parliament and of the Council on the approximation of the laws the Member States relating to the electromagnetic compatibility and with the requirements of standards as well EN/IEC 61000-3-3 and EN/IEC61000-3-2 within valid edition.

Vibrations caused by the product: product influence is negligible.

Noise produced by the product: The maximum allowable noise level (A) of the product measured in a place of operation is 78 dB (A).

1.3 Data specified on electric actuator

Nameplate:

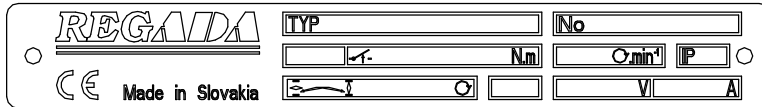

Warning plate:



Nameplate contains the basic data concerning identification, performance and electricity: indication of producer, type, serial number, max. load torque and switching-off torque, operating speed, protection code, number of revolution, supply voltage and current.

Graphic symbols on electric actuator

The graphic symbols used on electric actuator substitute the text messages. Some of them are in accordance with EN ISO 7010, ISO 7000 and IEC 60417 within valid edition.



Dangerous voltage

(EN ISO 7010-W012)

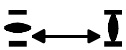

Stroke of the electric actuator



Switching-off torque



Manual control

(0096 ISO 7000)



Protection terminal

(5019 IEC 60417)

1.4 Instructions for staff training

Requirements for specialized skills of persons performing assembly, operation and maintenance



Electric connection can be performed only by an acquainted person, i.e. an electrical engineer with professional education of electrical engineering at an apprentice school or a technical school (secondary, complete secondary or university education) and whose qualification was verified by an educational facility authorised to verify professional qualification.



Service can be performed only by workers professionally qualified and trained by the producer or contracted service centre!

Product protection

EA **UM 2** does not have own short-circuit protection, therefore there must be included suitable protective device into the supply power (circuit breaker, or fuse), which serves at the same time as main switch.

Type of equipment from a connection point of view: The equipment is designed for permanent connection. For protection, we recommend to use a fuse type "T" or a contactor type "C".

1.5 Warranty conditions

The supplier is responsible for completeness of the delivery and guarantees these specifications of the product which are stated in the Contract.

The supplier is not responsible for any deterioration of parameters caused by the customer during storage, unauthorised installation or improper operation.

1.6 Under-guarantee and after-guarantee service

Our customers are provided with professional service of our firm in installation, operation, service, maintenance, revision and help in troubleshooting for all our products.

Under-guarantee service is performed by the service department of the production plant, or by a contracted service centre according to a written claim.

In case of occurring of any fault please let us know it and state:

- type code
- serial number
- ambient parameters (temperature, humidity...)
- duty cycle including frequency of switching
- type of switching-off (position or torque)
- set switching-off torque
- type of fault - description of claimed fault
- it is recommended to place also Installation certificate.

It is recommended to have **after-guarantee service** performed by the service department of the production plant, or by a contracted service centre, with national laws.

1.6.1 Lifetime of actuators

The lifetime of an electric actuator (EA) is at least 6 years.

EA used for closing mode (closing valves) comply with the requirements for at least **15,000 working cycles** (cycle C – O – C at 30 revolutions per operating stroke:for multi-turn EA)

EA used for regulating/modulating operation (control valves) comply with the below stated numbers of **operating hours** at the total number of 1 million start-ups:

Switching frequency				
max. 1,200 [h ⁻¹]	1,000 [h ⁻¹]	500 [h ⁻¹]	250 [h ⁻¹]	125 [h ⁻¹]
Minimal lifetime expectancy – number of operating hours				
850	1,000	2,000	4,000	8,000

Time of **net operation** is min. 200 hours, max. 2,000 hours.

Lifetime at operating hours depends on loading and switching frequency.

Note : High switching frequency does not ensure better regulation. Setting of regulation parameters should be therefore made with the inevitably necessary switching frequency needed for the process in question

1.7 Operation conditions

1.7.1 Product location and operation position

EA may be installed and operated in enclosed locations of industrial facilities with no temperature and moisture regulation, protected from direct climatic effects (such as direct sunlight). Moreover, special “marine” versions may be used in waste water treatment applications, water management, selected chemical applications, tropical environments and coastal areas.

Warning:



Actuator installed on the open place must be protected against a direct climate effects by shelter.

Installation and operation of EA is possible in **any position**. Vertical position of output part axis and with the control part above the valve is usual.

1.7.2 Working environment

According to valid standard IEC 60 721-2-1, there are delivered these versions of electric actuators:

- 1) Version „standard“ for type climate temperate
- 2) Version „tropical wet“ for type climate tropical wet
- 3) Version „cold“ - for type climate cold
- 4) Version „tropical dry and dry“ for type climate tropical dry and dry
- 5) Version „marine“ for type climate marine
- 6) Version „arctic“ for type climate arctic.

In accordance with IEC 60 364-1, IEC 60 364-5-51 within valid edition the EA have to resist external effects and operate reliably:

In the conditions of the following types of environment:

- warm mild to very hot dry with temperature in range -25°C to $+55^{\circ}\text{C}$ AA 7*
- cold to warm mild and dry with temperatures in range -50°C to $+40^{\circ}\text{C}$ AA 8*
- cold to mild hot dry with temperatures in range -60°C až $+40^{\circ}\text{C}$ AA 1*+AA 5*
- with relative humidity 10 to 100 %, including the condensation of up to 0,029 kg water content per 1 kg of dry air, at above stated temperature AB 7*
- with relative humidity of 15÷100%, including the condensation of up to 0,036 kg water content per 1 kg of dry air, at above stated temperature AB 8*
- with relative humidity 5 to 100 %, including the condensation of up to 0,025 kg water content per 1 kg of dry, at above stated temperature AB 1*+AB 5
- with elevation up to 2000 m, with barometric pressure range from 86 kPa up to 108 kPa AC 1*
- with exposure to intensive water jets (IPx6) AD 6*
- with immersion – (protection enclosure IP x 8) AD 8*
- with strong dustiness – with a possibility of influences of inflammable, non-conducted and non-explosive dust; the middle layer of dust; the dust drop more than 350 but not more than 1000 mg/m² per day (products with protection enclosure of IP 6x) AE 6*
- expose to corroding or pollute chemical substances during producing or using of these substances); at places where is handled with small quantity of chemical products and these can accidentally get in contact with an electric device AF 3*
- with permanent exposure of big amount of corroding or contaminated chemical and salt fog in execution for sea environment, fog sewage water disposal plant and some chemical plant AF 4*
- with a possibility of influences of mechanical stress:
 - medium sinusoid vibrations with frequency in range from 10 up to 150 Hz, with shift amplitude of 0,15 mm for $f < f_p$ and acceleration amplitude 19,6 m/s² for $f > f_p$ (transition frequency f_p is from 57 up to 62Hz) AH 2*
 - medium impacts, shocks and vibrations AG 2*
- with serious danger of plants and mould growing AK 2*
- with serious danger of animal occurrence (insects, birds, small animals) AL 2*
- with detrimental influence of radiation:
 - of stray current with intensity of magnetic field (direct or alternate, of mains frequency) up to 400A.m⁻¹ AM2-2*
 - of sun radiation with intensity > 500 and $\leq 700\text{W/m}^2$ AN 2*
- with effects of medium seismic activity with acceleration > 300 Gal ≤ 600 Gal AP 3*
- with direct endanger by storm AQ 3*
- with quick air movement and strong wind AR 3 , AS 3*
- stand on a conductive bottom) BC 3*
- without any danger media with object. BE 1*

* Marking in accordance with IEC 60364-1, IEC 60 364-5-51 and IEC 60 364-5-55 within valid edition

1.7.3 Power supply and duty cycle

Power supply:

electric motor 24 V AC/DC; 120 V AC, 230 resp. 220 V AC; 3x400 resp. 3x380 ±10%.
control 24 V AC resp. 230 V AC ±10%

Power supply frequency 50 Hz, or 60**Hz ± 2 %

** Rotation speed will increase 1,2 times, and torque will decrease 1,2 times

Duty cycle - according to EN/IEC 60034-1 within valid edition:

EA UM 2 are designed for **remote control**:

- short-time operation S2-10 min
- intermitted operation S4-25%, max. 90 cycles per hour

EA with controller are designed for for **automatic regulation**:

- intermitted operation S4-25%, 90 up to 1200 cycles per hour

Note:

1. Duty cycle consist of load type, load factor and switching rate.
2. Once EA is connected to the external controller unit, also use it as a control EA where the max. load torque reaches the 0.7 multiple of the maximum loading torque for remote operated EA UM 2

1.8 Packing, transport, storing and unpacking

Surfaces without surface treatment are treated by conservation preparation MOGUL LV 2-3 before packaging .

Conservation is not necessary if the following storage conditions are complied with:

- Storage temperature: -10 to +50 °C
- Relative air humidity max.80 %
- Electric actuators and their accessories must be stored in dry, well ventilated covered spaces, protected against impurities, dust, soil humidity (by placement to racks, or on palletes), chemicals and foreign interventions
- There shall be no corrosive gases present in the storage areas.

The of **UM 2** are delivered in solid packages guaranteeing resistance in accordance with EN/IEC 60 654.

Package is a box. Products in boxes is possible to load on the pallets (pallet is returnable). On the outer side of the package is stated:

- manufacturer label,
- name and type of product,
- number of pieces,
- other data – notices and stickers.

The forwarder is obliged to secure packed products, loaded on transportation means, against self-motion; if open transportation means are used, to secure their protection against atmospheric precipitations and splashing water. Displacement and securing of products in transportation means must provide their stable position, exclude the possibility of their inter-collision and their collision with the vehicle walls.

Transportation can be executed by heatless and non hermetic spaces of transportation vehicles with influences within the range:

- temperature: -25°C up to +50°C (a strange version –50 ° C up to +45 ° C)
- humidity: 5 up to 100 %, with max. water content 0.028 kg/kg of dry air
- barometric pressure 86 up to 108 kPa

After receiving EA check whether during transport or storage the actuator was not damaged. Compare also whether the parameters on their nameplates are in accordance with accompanying documentation or the Contract. If any discrepancy or fault occur inform immediately your supplier.

If the actuators and accessories are not immediately installed, they have to be stored in dry, well-ventilated sheltered rooms, protected against dirt, dust, soil humidity (with placing onto shelves or onto pallets), chemical impacts and encroachment, at ambient temperature from -10°C up to +50 °C and relative humidity max. 80 %, in special version at temperature –50°C do +40°C.

- It is forbidden to store EA outside or in areas not prevented against direct impact of climate.
- Strains of the surface finishing should be promptly removed if any – it can prevent the product against corrosion damages.
- While storing more than one year it is necessary to check lubrication filling before the actuator is put into operation.
- The EA installed but not operated are to be protected the same way as when storing (e.g. with a wrapping).
- After it is mounted onto a valve in free and wet areas or in areas where temperature is changing it is necessary to connect the space heater – to prevent the actuator against corrosion resulted from water condensed in the control part.
- Remove odd conservation grease as late as before putting into operation.

1.9 Assessment of the product and packaging and removal of contamination

The product and its package are made of recycling materials. Do not throw the single parts of the package and of the product after their life but sort them according to instructions in corresponding executives or regulations of environment protection, and allow their recycling.

The product and its packing are not a source of any environment pollution or contamination and do not contain any dangerous waste.

2. Description, function and specifications

2.1 Description and function

EA **UM 2** are of compact construction. They are composed of two functionally different main parts.

The **gear part** is made up by a flange with a connecting part resp. linear mechanism for connection onto a controlled device, and gears placed in the bottom; on the other side drive mechanisms for control part units are surfaced.

The **control part (Fig. 1, 1a)** is placed on a control board (1) consisting of:

- electric motor (2) (at single-phase version with capacitor)
- torque unit (5) (controlled with a worm axial shift)
- position-signaling unit (3) with a position transmitter (6) and with a mechanical local position indicator (4)
- space heater (8) with thermal switch (7)
- electronic module (contoller) (9)
- electrical connection through terminal boxes (10), located in the control area and cable glands Ex d version with direct entry with compound filling around cable cores
- relays of torque switch S1 or S2 (ReS11, ReS12) (12) – customized version

Additional accessories:

Manual control: made up by a hand wheel with a worm gearing.

Electric local control

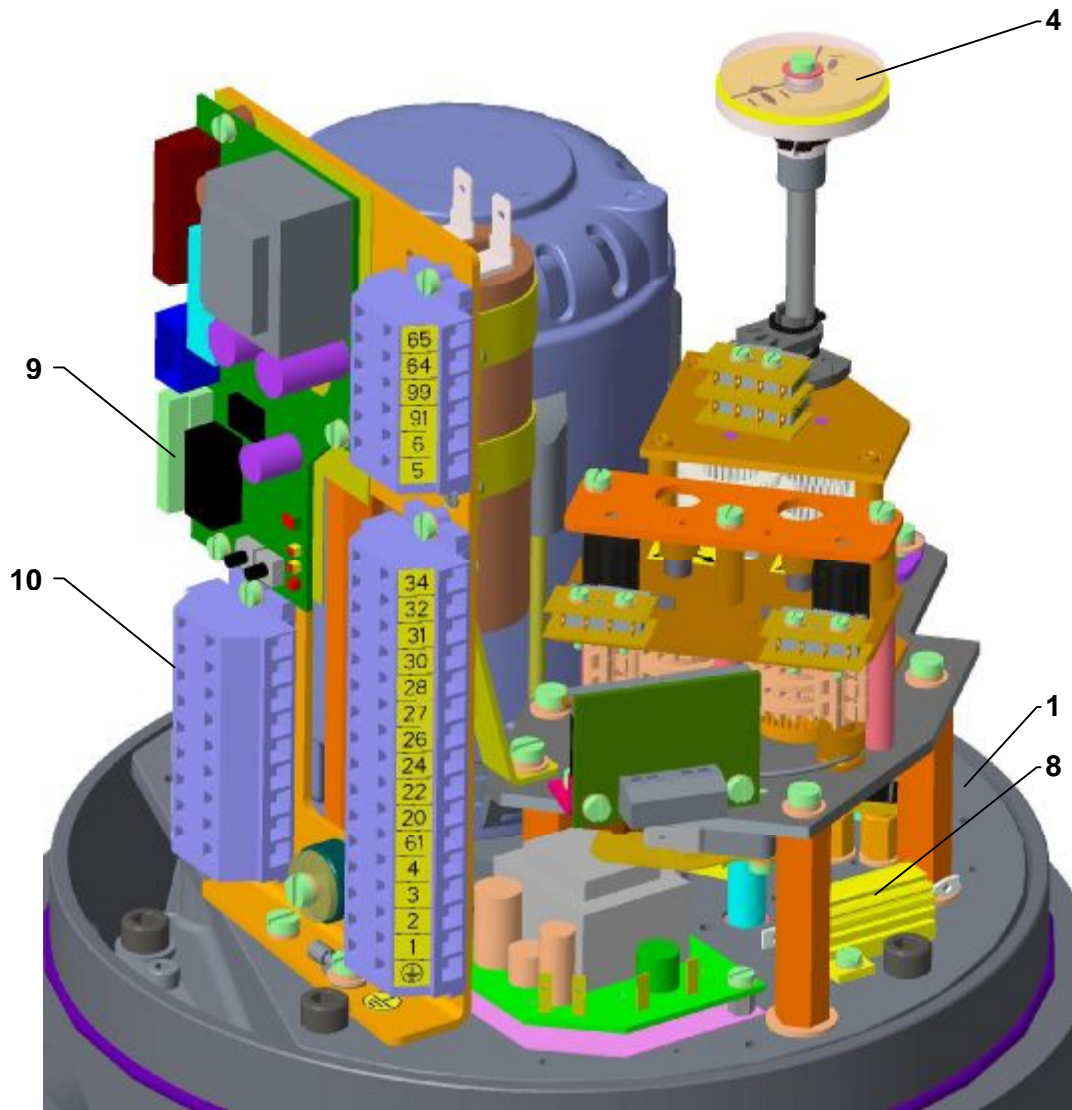

Fig.1

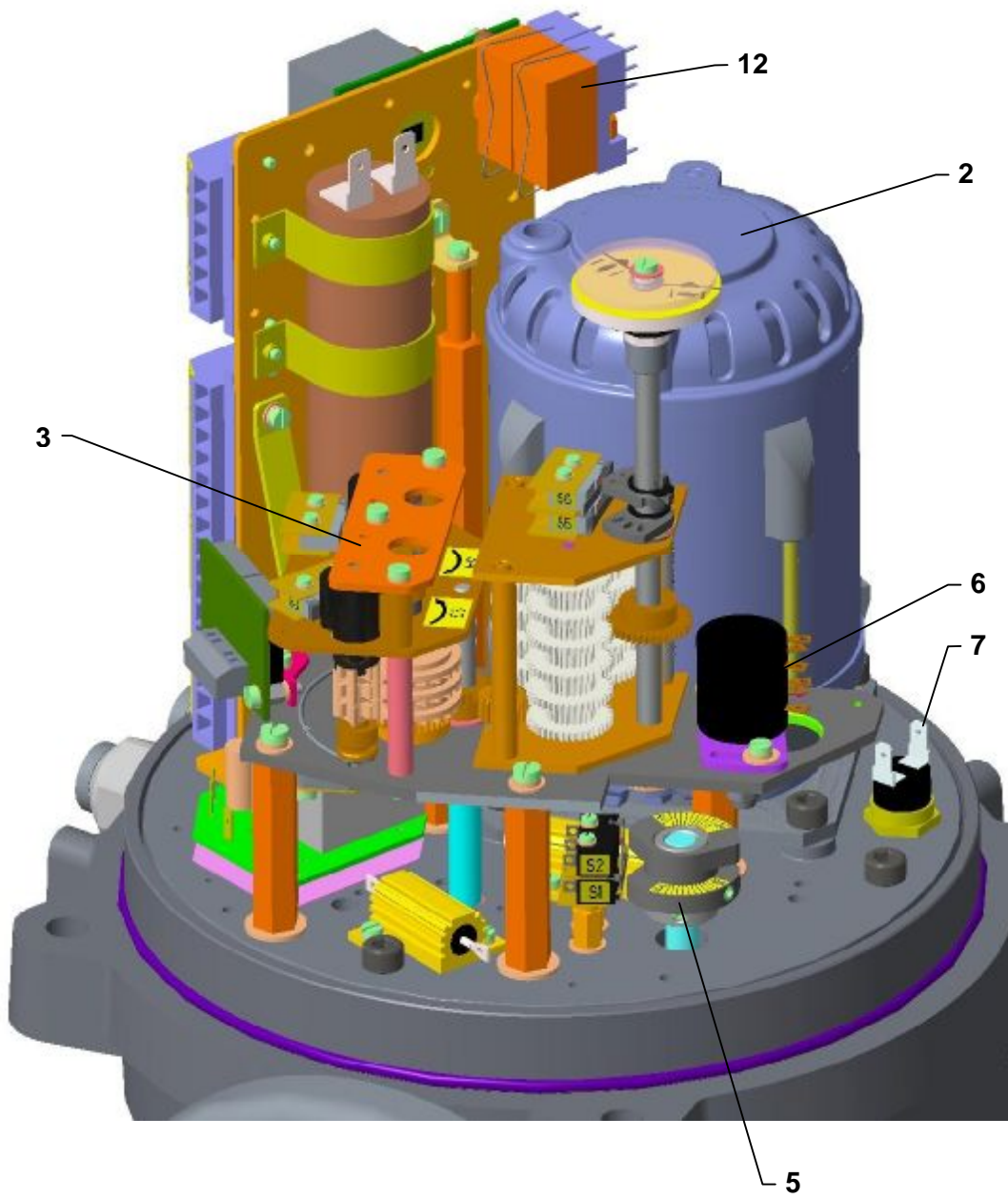

Fig.1a

2.2 Basic specifications

Basic EA specifications:
are given in Table 1.

Table 1: Basic EA specifications

Type number	Operating speed ²⁾	Number revol.	Max. load torque	Switching-off torque ±10 [%]	Weight	Electric motor ¹⁾						
						Power supply voltage	Nominal		Current		Capacitor capacity.	
							power	speed	nominal	starting ±20 %		
	[1/min]	[rev]	[Nm]	[Nm]	[kg]	[V]	[W]	[1/min]	[A]	[µF/V AC]		
1	2	3	5	6	7	8	9	10	11	12	13	
	50Hz 60Hz											
UM 2 type number 142	10	see table No.3	68	45-80	20 - 24	Single-phase	230 (220)	120	2600	1,0	1,9	8/450
	15		46	30-60								
	20		34	24-40								
	10 12		68	45-80								
	15 18		46	30-60								
	20 24		34	24-40								
	10		68	45-80								
	15		46	30-60								
	20		34	24-40								
	10		85	60-100								
	15		68	48-80								
	20		51	36-60								
	40		25,5	18-30								
						Single-phase/ Direct current	24 AC/DC	100	3350	4,9	-	-
						Three-phase	3x400 (3x380)	180	2650	0,6	2,4	-

1) Switching elements for different type of load (also for EA) defines standard EN/IEC 60 947-4-1.

2) Anomaly of operating speed ±10% at 230 V resp. 220 V AC, 3x400 resp. 3x380V AC.

Additional technical data:

EA protection enclosure: **IP 66/68** (EN/IEC 60529 within valid edition)

According to definition for EA, enclosure IP68 fulfills following requirements:

-water column max. 10m

-time of continuous submersion in water max. 96 hours

Mechanical ruggedness **see chapter 1.7.2 Working environment, code AH 2**

Self-locking: the EA is self-locked

Electric motor protection: with thermal switch

EA braking: by roller bief

Output part backlash:..... max.5 ° at load of 5%-of maximum torque

Electric control:

- remote control (the output element of the EA is controlled with supply voltage), resp. by feeding of unified signal

Adjustment of the limit positions:

The limit position switches are set to the number of work turns with accuracy of ± 90°.

Additional position relays (S5,S6) are adjustmentcca 1 rev. beneath the limit switches

Tandem position relays are adjustment..... just before the end positions

Hysteresis of position switches.....max. 180°

Unless the customer specifies the value of the particular working revol., revol. are set to **6st stage** of the selected stroke order – see Table 3.

Adjustment of the torque switches:

If other adjustment not specified the switching torque is set to the maximum value with tolerance of $\pm 10\%$.

Switches (S1, S2, S3, S4, S5, S6, S13, S14):

Type **DB 6: silver contacts** – standard version

Switches:

Silver microswitches – DB 6:

voltage 250 V(AC); 50/60 Hz; 20 mA to 2 A; $\cos\varphi = 0.6$;
24 V(DC) and 48 V DC; 20 mA to 1 A; $T=L/R=3\text{ms}$;
min. switching voltage 20V.

Gold switches – DB 3

max. 250 V AC; 1 mA to 0,1(0,05)A;
24 V DC and 48 V DC, 1 mA to 0,1 A ; $T=L/R=3\text{ms}$.

Relay thrust of switch S1, resp. S2 (ReS11, ReS12):

Model **RT 424**

- 250 V AC, 8 A; 24 VDC, 8 A; max. switching-on power AC 2000 VA

Space heater (E1)

Space heater - supply voltage: corresponding with motor supply voltage (max. 250 V AC)

Heating power: cca 40 W/55 °C

Switching resistorthermal switch

Thermal switch of space heater (F2)

Supply voltage: corresponding with motor supply voltage (max. 250V AC)

Switching-off temperature:..... $+20^{\circ}\text{C} \pm 3\text{K}$

Switching-on temperature:..... $+30^{\circ}\text{C} \pm 4\text{K}$

Manual control:

By handwheel after unscrewing the locking screw . Rotate the handwheel clockwise to move the output shaft in the direction „Z“.

Position transmitters**Resistive position transmitter RP 19:**

Resistance (single **B1**) 100; 2 000 Ω
(double **B2**) 2x100 Ω , 2x2000 Ω
Operating life of transmitter $1 \cdot 10^6$ cycles
Load capacity 0,5 W do 40 °C, (0 W/125°C)
Nominal current of sliding contact max.35 mA
Maximum supply voltage..... $\sqrt{P \times R}$ V DC/AC
Potentiometer linearity error $\pm 2,5 [\%]^1$
Potentiometer hysteresis max. 5 $[\%]^1$
Potentiometer values at limit positions: "O" (open)..... $\geq 93\%$, "Z" (closed)..... $\leq 5\%$

Capacitive (B3a): non-contact, life 10^8 cycles

2-wire connection with built-in power supply or without built-in power supply

The current signal **4** , **20 mA** (DC) is acquired from the capacitive transmitter supplied from the internal or an external voltage supply source. The electronics of the transmitter is protected against eventual wrong polarity and current overloading. The entire transmitter is galvanic insulated so several transmitters can be connected to one external voltage source.

Power supply voltage (with power supply) 24 V DC

Power supply voltage (without power supply) 18 to 28 V DC

Ripple voltage max. 5%

Max power input 0,6 W

Load resistance 0 to 500 Ω

Load resistance can be single side grounded.

Influence of resistance on output current 0,02%/100 Ω

Influence of voltage on output current 0,02%/1V

Temperature dependency 0.5% / 10 °C

Output signal values at limit positions:

"O" 20 mA (terminals 81; 82)

"Z" 4 mA (terminals 81; 82)

Values tolerance of output signal of EPV

„Z“ +0,2 mA
 „O“ ±0,1 mA

DCPT3M – current transmitter (B3b)

- **2-wire connection** without built-in power supply or with built-in power supply

Current signal **4 ÷ 20 mA** (DC) with optional mirroring (**20 ÷ 4 mA**)
 Mode of operation contactless, magnetic resistance
 Transmitter increments without gears 0,0879 °
 Loading resistor: max. 500 Ω
 Operating stroke 35 to 100% of the rated stroke at the gear ratio
 Non-linearity max. ±1 %
 Non-linearity - geared max. ±2.5 %
 Power supply voltage for version without power source 15 through 30 V DC, max. 42 mA
 Power supply voltage for version with built-in power source 24 V DC
 Operating temperature -40 to +80°C
 Values tolerance of output signal of EPV „Z“ +0,2 mA
 „O“ ±0,1 mA
 Linearity deviation: ±2.5 %¹⁾
 Hysteresis max. 2.5 %¹⁾
 Error messages by flashing LED

1) from rated value of transmitter referred to output values

Electronic positional transmitter (EPV) - converter R/I (B3)

2-wire version, resp. 3-wire (without built-in power supply, or with built-in power supply)

Output signal for 2-wire version 4 ÷ 20 mA (DC)
 Output signal for 3-wire version 0 ÷ 5 mA (DC)
 0 ÷ 20 mA (DC)
 4 ÷ 20 mA (DC)
 0 ÷ 10 V (DC)
 Power supply voltage for **2-wire version without built-in power supply** 15 to 30 V DC
 Power supply voltage for **2-wire version -with built-in power supply** 24 V DC ± 1,5%
 Load resistance for **2-wire version** max. $R_L = (U_n - 9V) / 0,02A$ [Ω]
 (U_n – voltage [V])
 Power supply voltage (at version without built-in power supply) 24 V DC ± 1,5%
 Load resistance for 3-wire version 0-5mA max. 3 kΩ
 Load resistance for 3-wire version 0/4-20mA max. 750 Ω
 Load resistance for 3-wire version 0-10 V max. 10 kΩ
 Temperature dependency max. 0,020 mA / 10 °C
 Output signal values at limit positions on the terminal 81,82 „O“ 20 mA (5 mA, 10 V)
 „Z“ 0 mA (4 mA, 0 V)
 Values tolerance of output signal „Z“ +1,5 %¹⁾
 „O“ ±1,5 %¹⁾
 Linearity deviation ±2,5 %¹⁾
 Hysteresis max. 2,5 %¹⁾

1) from rated value of transmitter referred to output values

Electronic position controller (N) „REGADA" (Valid for the EA version with controller only)**Controller software equipment:****A) Function and parameters**programmable **functions:**

- with functional buttons SW1, SW2 and LED diodes D3, D4 directly placed on controller
- with computer or terminal equipped with corresponding programme, using RS 232 interface.

programmable **parameters:**

- control signal
- response to SYS-TEST signal
- mirroring (ascending/descending characteristics)
- insensitiveness
- EA limit positions (only with computer and ZP2 programme)
- way of regulation

B) Operation states of controller**Error message** from error memory: (using LED diodes and RS 232 and personal computer)

- control signal missing or faulty
- input value of current control signal under 3.5 mA
- existence of SYS-TEST signal
- activity of switches
- failure of feedback position transmitter

Statistic data: (using RS 232 and personal computer)

- number of controller operation hours
- frequency of relay switching in direction "opening"
- frequency of relay switching in direction "closing"

Supply voltage terminal 61 (L1) -1(N) 24 V AC, 120 V AC, 230 V AC, $\pm 10\%$ **Frequency:** 50/60 Hz $\pm 2\%$ **Input control signals - analogue:** 0 - 20 mA

..... 4 - 20 mA

..... 0 - 10 V

Input resistance for signal 0/4 - 20 mA..... 250 Ω **Input resistance for signal 0/2 - 10 V**..... 50k Ω

(Actuator opens at rising of control signal.)

Controller linearity: 0.5 %**Controller insensitiveness:** 1 - 10% (adjustable)**Feedback (position transmitter):** resistive 100 up to 10,000 Ω

..... current 4 up to 20 mA

Power outputs: 2x relay 5A/250V AC**Digital outputs:**4x LED (supply, error, adjustment, "opening", "closing" - with two-colour LED)**Error status:** control switch 24 V, 2W - POR**Reaction at error situation:** transmitter error - error message LED**Control signal missing:** error message LED**SYS mode:** error message LED**Adjusters:** communication connector

..... 2x calibrating and adjusting button

2.2.1 Mechanical connection

- flange (ISO 5210), pillars

Basic and connecting dimensions are given in dimensional drawings.

2.2.2 Electrical connection

The electric connection should be made according to wiring diagrams pasted into the top cover of the EA.

To terminal board (X) - max. 32 screw-less terminals with connecting wire cross-section of 0,08 to 2,5 mm². Stripping length of wires to screwless terminals is 8 to 9 mm.

To connector (XC) - max. 32 screw-less terminals with connecting wire cross-section max. mm2. Stripping length of wires to crimping cavities is 7.5 mm.

Cable glands for terminal connection:

For version without local control:

- 3 cable glands - M20x1,5 – diameter cable 8 to 14,5 mm

For version without local control:

- 2 cable glands - M20x1,5 – diameter cable 8 to 14,5 mm

Cable glands for connector connection:

For version without local control or with local control: :

- 2 cable glands - M20x1,5 – diameter cable 8 to 13 mm

Wire stripping length of the wires for screwless terminals is from 8 to 9mm.

Protective terminal:

Upon start-up in operation - at equipment installation:

- for safe use of the actuator it is necessary to connect the outside and inside grounding terminal. The position of the outside and inside grounding terminal can be seen in Fig. 1c and Fig. 1d. HP3 insulated eyelet crimping pliers should be used to crimp wire to the outside grounding terminal (fy CEMBRE).

There must be included power switch or motor circuit breaker to the power supply, which should be selected according to the electric motor power for the output parameters according to Table 2 (e.g. motor-overcurrent circuit breaker MIS 32 - ... manufacturer SEZ; P25M manufacturer Schneider respectively PKZM01.... fy Eaton). It must be placed as close as possible to the device, easily accesible to the operator and marked as an disconnecting device of actuator.

Table 2 selection of fuse to electric motor						
Single-phase	Three - phase					Adjustable range of circuit-breaker
220 V AC 230 V AC 240 V AC	220 V AC 230 V AC 240 V AC	380 V AC 400 V AC 415 V AC	440 V AC	500 V AC	660 V AC 690 V AC	
(kW)						(A)
-	0,06	0,09	0,09...0,12	0,09...0,12	0,18	0,25...0,4
-	0,09	0,12...0,18	0,16	0,18	0,25	0,4...0,63
0,06...0,09	0,09...0,12	0,18...0,25	0,25...0,37	0,25...0,37	0,37...0,55	0,63..1

Outside and inside, mutually interconnected and identified with a protective grounding symbol.

Electric connection: - according to the wiring diagram stuck into the case of the EA.



Obr.1c

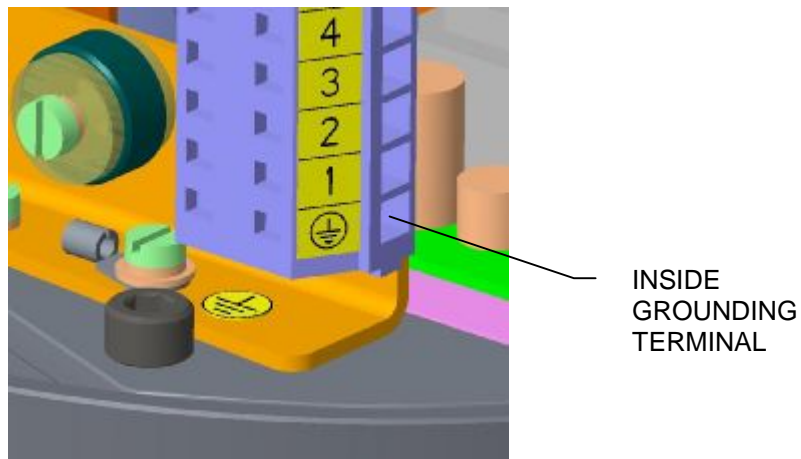

Obr.1d

3. Installation and dismantling of actuator



Abide by safety measures!

Note:

Check again if placement of EA reply to chapter "Operation conditions". In case that operation conditions are different from recommended, consultation with producer is needed.

Before starting of mounting the EA onto the valve:

- Check again whether the EA was not damaged during storing.
- Check whether the adjusted operation stroke and connecting dimensions of the actuator (see the nameplate) are in compliance with the valve parameters.
- In case of inconsonance, perform adjusting according to the part "Adjustment".

3.1 Installation

EA is by the producer adjusted to parameters according to the nameplate.
Before installation put the hand wheel on.

3.1.1 Mechanical flange connection

- Defat the abutting areas of the connecting flange of the EA valve or the gear carefully;
- Lubricate the output shaft of the valve/gear with a grease not containing any acids;
- Set the EA to the limit position "closed", set the valve to the same position;
- Put the EA onto the valve with the output shaft reliably stalled in the valve coupling/gear;

Attention! Do not adjust EA on an armature forcibly because of damage of the gear!

- Use the hand wheel to turn the EA to fit the openings in the EA and valve flanges if needed;
- Check whether the connecting flange abuts with the valve/gear;
- Fix the flange with four screws (with mechanical strength min 8G) fixed the way the actuator can Be moved. Tighten the screws equally in cross;
- At the end check the correctness of the fixture with the valve with rotating the hand wheel.

3.1.2 Electric connection and checking of function

Follow up with connecting the EA with mains or master system.



1. Follow instructions in the part "Requirements for professional qualification"!

2. While laying electrical line abide by the instructions for heavy current installations. Power supply cables must be of the type approved. Minimum thermal resistance of power supply cables and wires must be +90°C.

3. Cables to terminal boards or connectors lead through screw cable glands.

4. Before initiation ES into operation internal and external protection terminals are needed to be connected.

5. Feeding cables are to be fixed to the solid construction at most 150 mm from the cable glands.

6. Torque switching is not fitted with mechanical interlocking device.

7. For proper EA functioning the torque (S1, S2) and position (S3, S4) limit switches must be serial connected into the electric motor control circuit – see the recommended connection for single phase electric motor (example connection 1) and for 3 - phase electric motor (example connection 2).

8. The output wires electric motor thermal protection must be connected into the electric motor control circuit on a such way that when the electric motor thermal protection opens (it means when the allowed electric motor winding temperature is exceeded) it will cause the disconnection of the electric motor supply voltage.

9. To prevent moisture from entering the actuator around the connecting cables, the cables must be sealed with silicone material at the point of penetration through device shell.

Connection with the terminal board:

Before the connection remove the actuator case and check whether the type of current, power supply and frequency correspond with the data on the actuator nameplate.

Electric connection:

- The electric connection should be realized according to the wiring diagram stuck into the case of the EA;
- The electric connection should be performed through two cable glands see No. 2.2.2.

- Once electrical services are completed put on the cover and fasten it evenly crosswise by bolts. Fasten the cable glands to ensure specified shielding.

Connection to connector:

- Check whether the type of current, supply voltage and frequency correspond with data on the nameplate of electric motor.
- Release the connectors shells;
- Insulate the ends of conductors;
- Connect the appropriate sleeve connector by means of recommended pliers;
- Insert the sleeves into appropriate connector contacts according to connecting wiring diagrams.
- Fix the connectors and tighten them;
- Tighten the cable glands firmly to assure the protection enclosure rate.

Notes:

1. *The EA are delivered with cable glands which in case of correct tighten are onto the supply lead allow the protection enclosure of IP 68.*
2. *The cable is to be fixed the way corresponding with its allowable bending radius not to damage or deform the sealing element of the cable lead. The supply leads have to be fixed onto a fixed construction max. 150 mm from the leads.*
3. *It is recommended to connect the remote transmitters with shielded wires.*
4. *The face areas of the control part cover should be clean before fixing it back.*
5. *The EA is reversible if the time interval between the power supply is switched off and on for the reverse direction of the output part motion is at least 50 ms.*
6. *The allowed delay after it is switched off, i.e. time from the switches reaction up to the motor without any voltage is 20 ms maximally.*

Example of electric motor connection with position and torque switches.

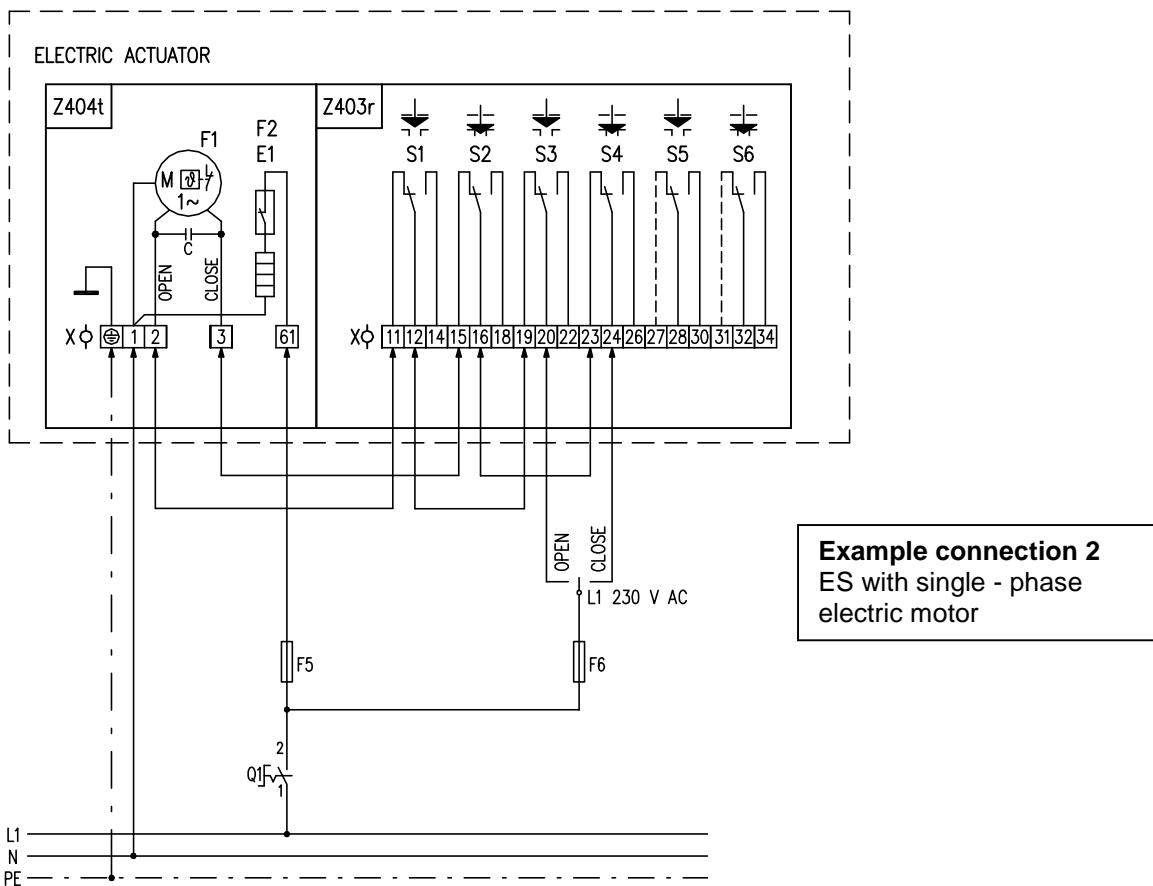
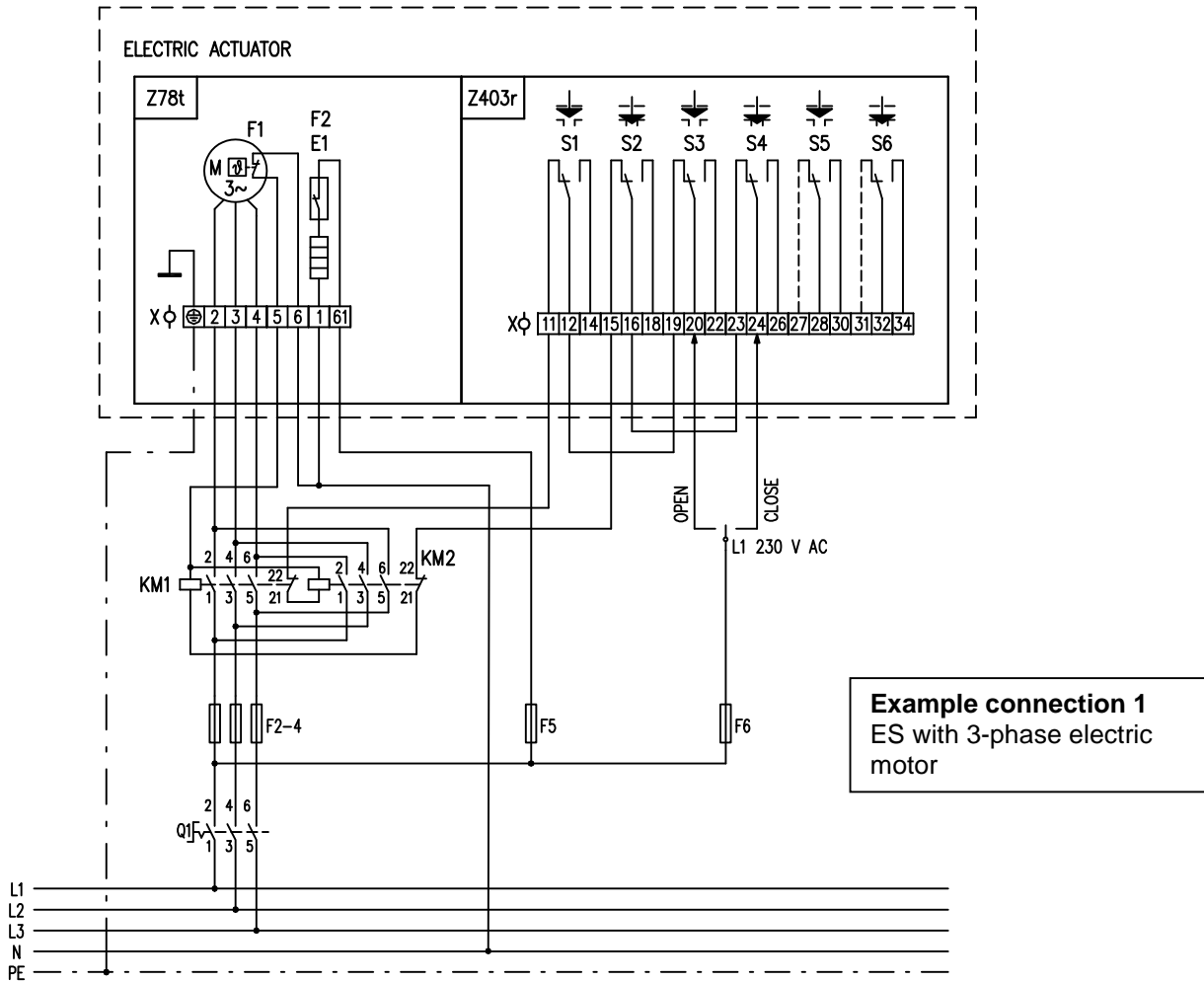



Observe the valve manufacturer's instructions with respect to the requirement to ensure switching-off in limit positions through position or torque switches!

Caution:



1. Power supply to the actuator and connections with switching, protective and safety devices may be carried out only by personnel with appropriate qualification, in compliance with the corresponding standards and wiring diagrams, such as those specified in the Instruction Manual....
2. All terminal connections must be checked after connection of the power supply cables. The conductors must not apply any bending or tensile stress upon the connecting terminals. The following measures should be taken when using aluminum conductors:
3. Immediately before connecting the aluminum conductor, it is necessary to remove the oxide layer on the surface and prevent the oxidation by application of neutral vaseline to protect the connection.

After connection, check the correct direction of the actuator shaft rotation by short activation of the actuator in intermediate position. This can also be checked by using a stick made of insulating material to activate the corresponding micro-switch - limit, position or torque (depending on the type of actuator control) during operation of the actuator.

If the actuator does not stop, but stops upon signal from micro-switch corresponding to the opposite rotation direction, you will need to change the direction of rotation of the actuator output shaft. In case of an actuator driven by single-phase electric motor, the direction of rotation can be changed by switching the supply cables on the terminals of the electric motor.

In case of actuators with three-phase electric-motor, interconnect one of the pairs of conductors on terminals U, V, W of the actuator terminal board. Repeat the function test again.

Important!

- 1) During adjustment, repair and maintenance, secure the actuator by prescribed means in order to prevent its power-up resulting in the possibility of electric shock injury or injury by rotating parts.
- 2) When reversing the operation of actuators with single-phase electric motor, power supply must never be connected simultaneously to both outputs of the start-up capacitor at the same time, otherwise the capacitor could discharge through torque switch contacts resulting in their sticking together.

After adjustment of the actuator, check its operation using the control circuit. Especially make sure that the actuator starts-up correctly and that the electric motor is disconnected from power supply after triggering of the corresponding micro switch. Otherwise immediately disconnect the power supply to the actuator to prevent damage to the electric motor and try to locate the malfunction.

After the EA is electrically connected it is advised to **check functions**:

- After the EA is electrically connected to check the correct functions of the position and the torque switches S1 - S6 and if needed adapt the order of the single phase leads for the 3-phase electric motor.
- Set the valve manually into an mid-position.
- Connect the power supply to the terminal for supplying the EA in the direction "opening" and follow the direction of the output shaft of the actuator rotation. When EA is connected correctly, the output shaft of EA, into the actuator control part from the top, must rotate counterclockwise. If not, it is necessary to change the phase leads L1 and L3 on the terminals 2 and 4 mutually, valid for 3-phase electric motor. After the exchange is made check the direction of the EA rotation.
- If any of the functions is not correct, check the switches whether they are wired properly according to the wiring diagrams.

3.2 Dismantling



Attention!

**Before disassembly is necessary to disconnect electric supply of electric actuator!
Secure by prescribed way protection against connection of EA to the network and thus potential electrical accident!**

- Disconnect the EA from mains.
- Disconnect the leads from the EA terminal boards and loosen the cables from cable glands. Pull out the connectors in case of the connector version.
- Loosen the fixing screws of the EA flange and coupling screws and disconnect the EA from the valve.
- While sending the EA to be repaired put it into a package solid enough to avoid damages of the EA during transportation.

4. Adjustment



Attention! See chapter 1.2

If it is necessary to connect the supply voltage to Electric actuator, make sure by following the mentioned procedure that there is no injury caused by the electric current. Otherwise, disconnect the Electric actuator from the electricity network.

Observe safety regulations!

After mechanical connection, electrical connection and checking of connection and function start setting and adjustment of the device. The adjustment can be performed at a mechanically and electrically connected EA. This part describes adjustment of EA to specified parameters in case that any unit of EA is reset. Laying of adjusters of the control board is shown on Fig.1 and Fig. 1a.

Definition of the direction of movement:

- movement direction "close" - the output shaft of the actuator rotates in the clockwise direction when looking into the actuator control part from the top.

4.1 Adjustment of the torque unit

The switching - off torque are adjusted by the producer for both directions, i.e. for the direction "opening" (the torque switch S1) as well as for the direction "closing" (the torque switch S2) to the specified value with tolerance of $\pm 10\%$. If not stated else they are adjusted to the maximum rate.

Adjustment and setting of torque unit to different torque values is possible by torque unit cams adjustment. Switching-off torque can be reduced only. Torque reducing is done by cam screw releasing and turning this cam against a mark on torque unit shaft. Adjustment close to MAX mark means maximum torque. It is not allowed to go outside this mark. Adjustment close to MIN mark does not mean minimum torque, it is just an information about torque reducing direction.

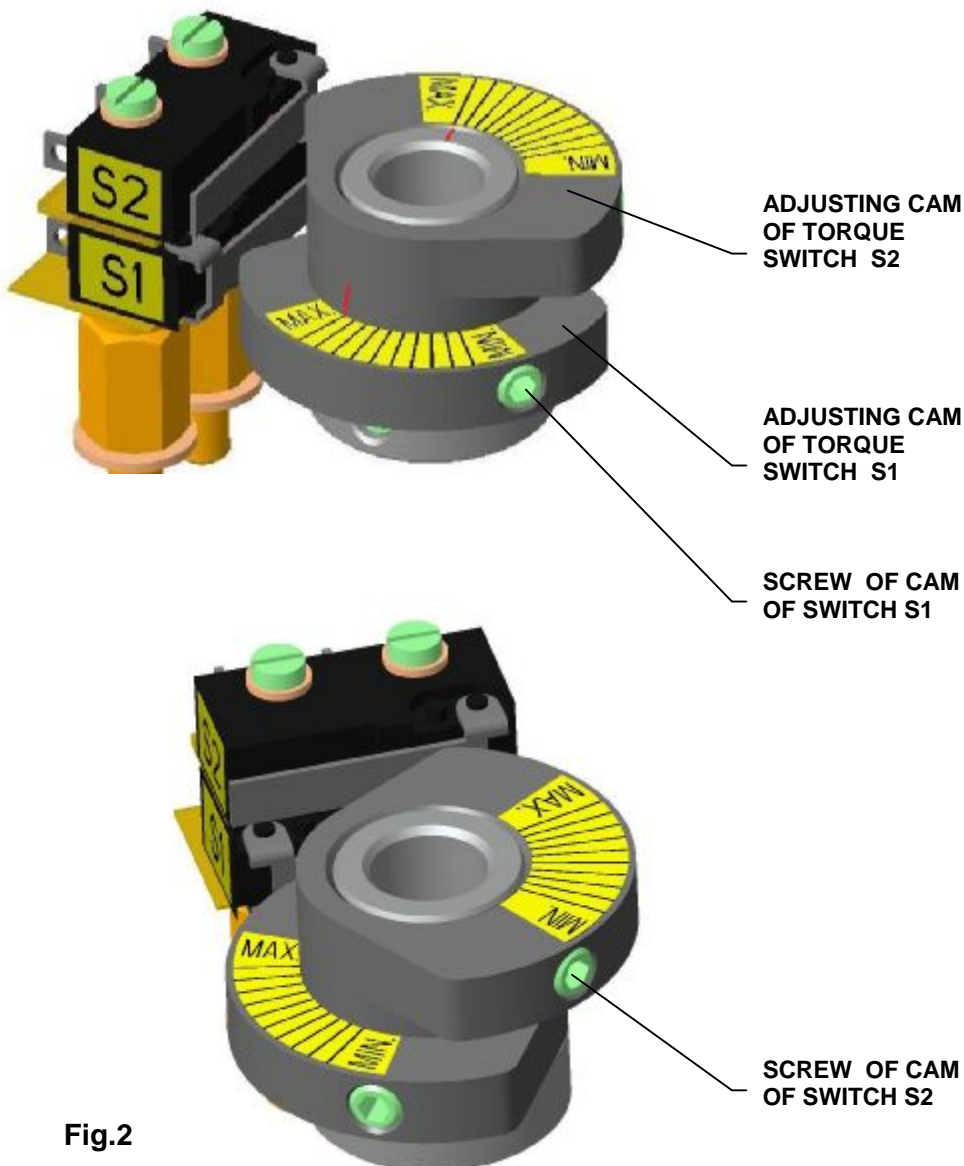

Fig.2

4.2 Adjustment of position-signalling unit (S3(S13),S4(S14)) (Fig.6)

EA is delivered set to a stroke corresponding to 6th according to table 3 or to a stroke required by customer. The procedure for position switches setting, adjustment a new setting is as follows (Fig. 6, 7):

- Having the set screw of the gear unit wheel released, move the adjustable wheel to a required stage of the range (it means to a one corresponding accurately to the particular revolutions, or to the next higher one) according to table 3 and Fig.7. When moving the adjustable wheel, take care to achieve the proper meshing with the gear wheel of the subjected stage, and then tighten the set screw back.
- Move EA to the "open" position electrically or manually. If, with electric move, EA has been switched off by S3 switch (Fig. 6), insert a screwdriver into set screw (29), press it and rotate in the arrow direction until an appropriate cam opens S3 switch. Pull the screwdriver out (see notice 1) and continue in moving EA in the „open“ position.
- In the „open“ position, insert a screwdriver into set screw (29), press it and rotate in the arrow direction until an appropriate cam closes S3 switch. Pull the screwdriver out (see notice 1).
- Move EA to the "close" position electrically or manually. If, with electric move, EA has been switched off by S4 switch (Fig. 6), insert a screwdriver into set screw (28), press it and rotate in the arrow direction until an appropriate cam opens S4 switch. Pull the screwdriver out (see notice 1) and continue in moving EA in the „close“ position.
- In the „close“ position, insert a screwdriver into set screw (28), press it and rotate in the arrow direction until an appropriate cam closes S4 switch. Pull the screwdriver out (see notice 1).
- Having position switches adjusted, You may need (depends on EA accessories) to adjust signaling switches, and position indicator.
- *Notice 1: in the case that the set screw remains pressed notwithstanding the screwdriver is out (it means that disengaged gear wheels don't mesh each other), turn gently the set screw against the arrow direction without pressing it until the set screw releases back to its initial position.*
- *Notice 2: In the variant of the **EA equipped with the S13, S14 tandem position switches**, these switches are to be adjusted after having the setup of the S3 a S4 switches completed, it means the S3 switch must switch simultaneously with the S13 switch, and the S4 switch must switch simultaneously with the S14 switch.*
- *Notice 3: By revolutions and speed adjustment it is necessary to keep actuators working duty.*

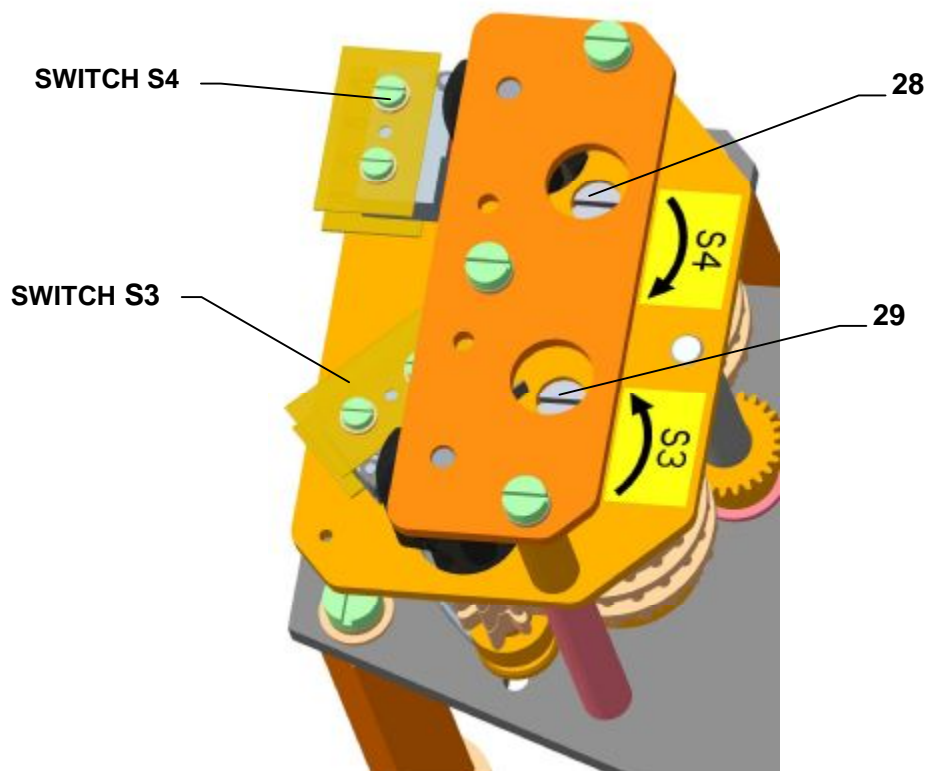
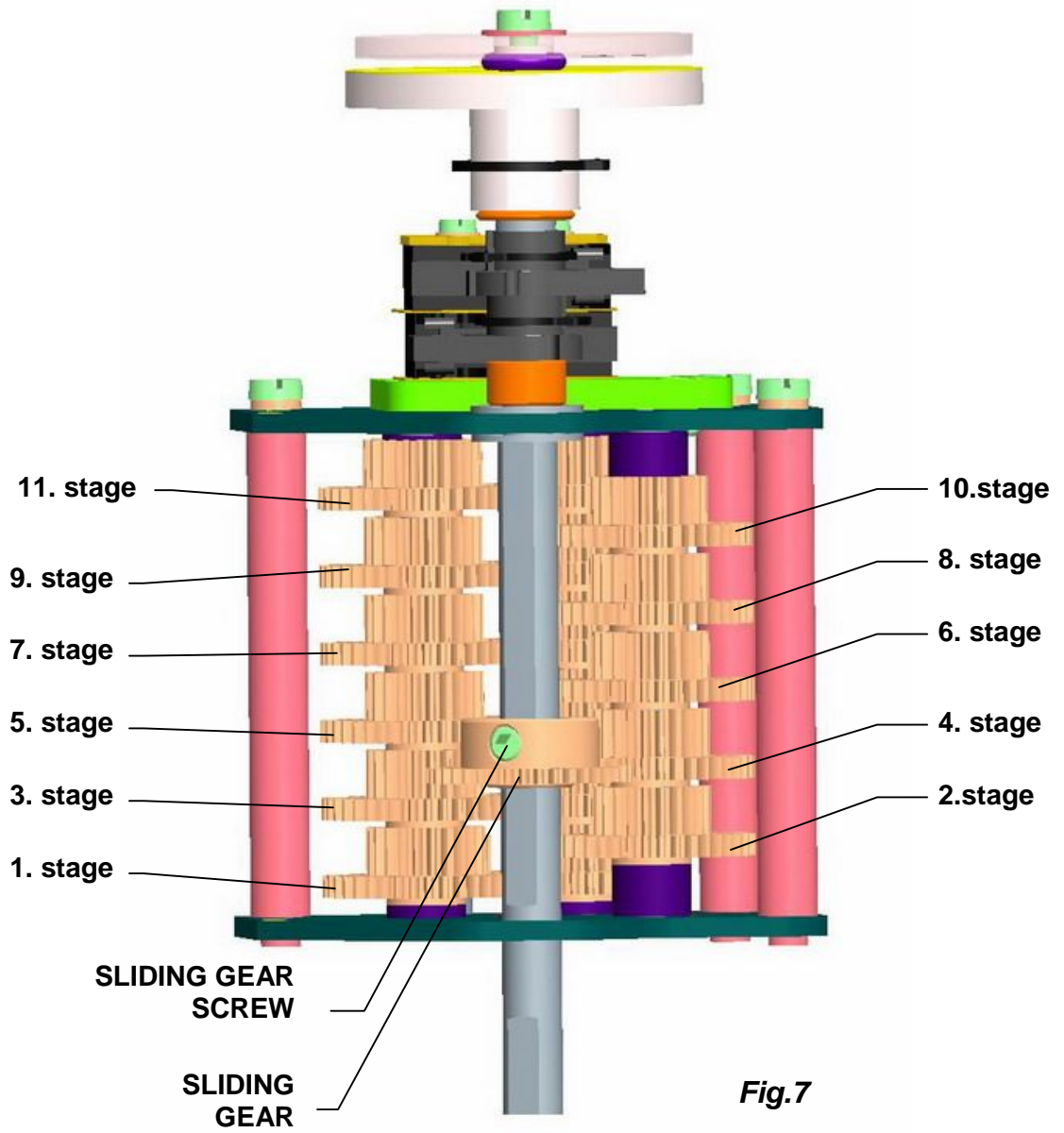

Fig.6

TABLE 3						
STROKE STAGE	MAX. REVOLUTIONS OF EA UM 2 if the customer doesn't specify a producer, EA will be set up to the 6.stage of stroke) Note: for CPT transmitter maximum revolutions according to RADA II.					
	STROKE LINE I	STROKE LINE II	STROKE LINE III	STROKE LINE IV	STROKE LINE V	STROKE LINE VI
1.stage	1,1	-	-	1	-	-
2. stage	2	1,5	1,6	1,8	1,2	1,3
3. stage	3,5	2,8	3	3,2	2	2,4
4. stage	6,4	5	5,3	5,8	4	4,2
5. stage	11,5	9	9,5	10,5	7	7,5
6. stage	21	16	17,5	19,5	13	14
7. stage	39	30	32	35	24	25
8. stage	70	55	58	64	43	46
9. stage	128	100	106	116	78	84
10. stage	232	180	193	211	140	150
11. stage	420	330	350	385	260	275



4.3 Signaling switches adjustment (S5,S6) (Fig. 8)

The signaling switches of EA are at producer preset to switch on about 10% before end positions provided the customer not specified otherwise. Before proceeding with signaling switches adjustment, S3, S4 end position switches must be adjusted according to the previous chapter if necessary. The procedure of signaling switches adjustment is as follows:

- Check that the adjusting wheel of the signalling gearbox is adjusted to the required level of the stroke scope.
- Bring EA to a position in which You want S5 switch to close when EA is running in the „open" direction.
- Turn cam (31) of S5 switch (27) clockwise until S5 switch closes.
- Bring EA to a position in which You want S6 switch to close when EA is running in the "close" direction.
- Turn cam (30) of S6 switch (26) counterclockwise until S6 switch closes.

Notice: This signaling is capable to signalise from 50 up to 100 %..of the working stroke in both movement directions. With switch reversing function, a signaling capability from 0 up to 100 % is available.

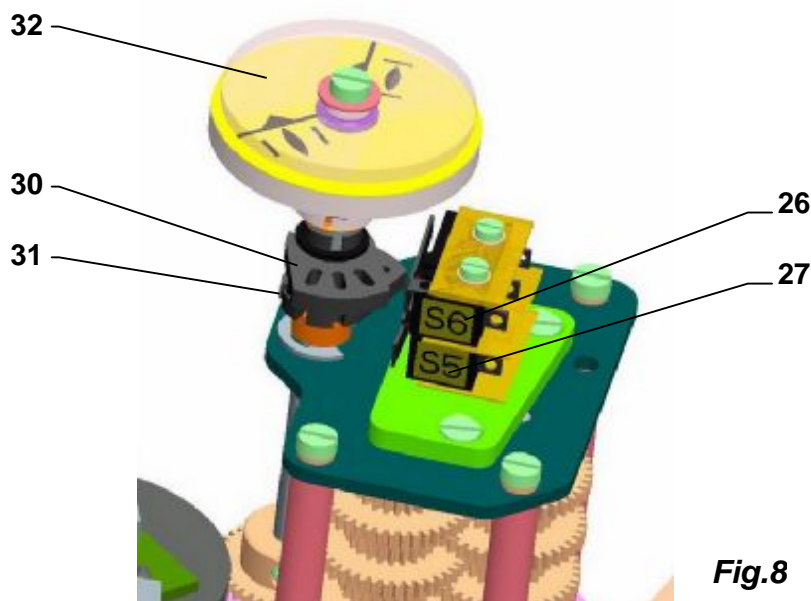

4.4 Position indicator adjustment (Fig.8)

The position of the output member relative to the end positions of EA stroke is indicated by a mechanical position indicator.

- Before starting to adjust the position indicator, S3 and S4 position switches must be adjusted if required.
- The procedure of position indicator adjustment is as follows :
- Bring EA to the „closed“ position.
- Turn the position indicator disc (32) to bring a mark identified with a symbol for the „close“ direction in coincidence with a mark on the upper cover aperture (If it is difficult to turn the wheel, release the screw using the screwdriver to fix the wheel).
- Bring EA to the „opened“ position.
- Turn the upper part of the position indicator disc (32) to bring a mark identified with a symbol for the „open“ direction in coincidence with the mark on the upper cover aperture.

4.5 Adjustment of resistant transmitter (Fig.9)

The **resistant transmitter** is in the EA used to function as a remote position indicator.

Before the resistant transmitter adjustment the position switches have to be adjusted (S3,S4). Adjustment consists in setting of the resistance in the defined limit position of the EA.

Notes:

In case that the EA is unused within the complete operating speed range following the angle selected on the particular stroke line, the "Open" limit position resistance value will undergo proportional reduction.

The transmitters are used with resistance according to the customer's specification. With EA of 2- wire converter a transmitter of 100 W resistance is used .

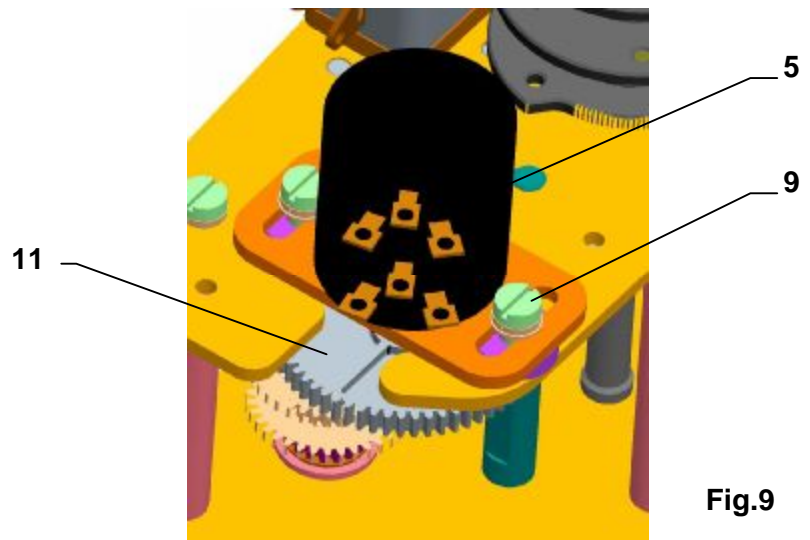

Fig.9

To adjust the transmitter follow these steps:

- Loosen the fixing screws (9) of the transmitter holder and push the transmitter out of mesh.
- Put the actuator to the position "closed" (with the handwheel, until the corresponding position switch S2 or S4 switches).
- Connect the measuring instrument for measuring the resistance to terminals 71 and 73 on the Electric actuator local control terminal box, or to terminals 7 and 10 on the Electric actuator local control controller with the disconnected supply voltage to Electric actuator and with the disconnected input signal into the controller (terminals 86-88).
- Rotate the transmitter (11) shaft until resistance of $\leq 5\%$ of the nominal transmitter resistance can be read on the meter in case of EA, and 4 up to 7% of the nominal transmitter resistance in case of EA with controller, i.e. with the resistant transmitter with the converter PTK1.
- In the position put the transmitter to mesh with the drive wheel and fix the fixing screws on the transmitter holder. Disconnect the meter from the terminal board.
- If when in the open position, the value of the resistance of the transmitter is greater than permitted, then the working stroke must be reduced.

4.6 Adjustment of the Electronic Position Transmitter (EPV) - the Resistive Transmitter (Potentiometer) with the Converter PTK 1

4.6.1 EPV – the 2-wire version (Fig. 10)

The position transmitter with the converter PTK1 is in the plant adjusted to have the output current signal on the terminals 81-82 (the wiring diagram Z23) as follows:

- in the position "open" 20 mA
- in the position "closed"4 mA

If the transmitter requires a new adjustment follow these steps:

- Put the actuator to the position "closed" and switch the power supply off.
- Adjust the resistive transmitter according to the previous chapter. The resistance is to be metered on the terminals R-R (Fig. 10). The used transmitter resistance is 100 Ω.
- Switch the converter's power supply on.
- Turn the adjusting trimmer ZERO (Fig. 10) to adjust the output current signal rate measured on the terminals 81-82 to 4 mA.
- Set the actuator to the position "open".
- Turn the adjusting trimmer GAIN (Fig. 10) to adjust the output current signal rate measured on the terminals 81-82 to 20 mA.
- Check the output signal of the converter in the both limit positions, and repeat the procedure if needed.

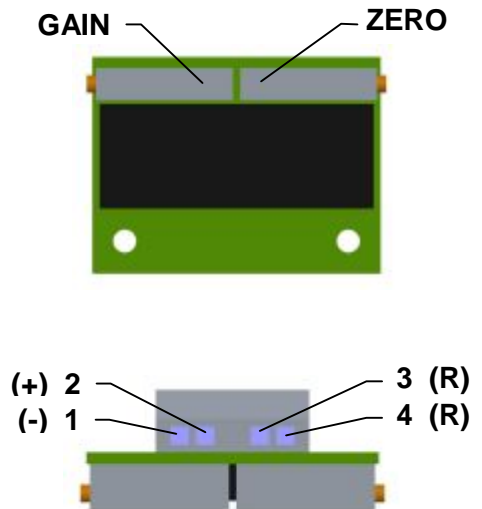

Fig.10

Note:

The output signal of 4-20mA can be adjusted at the range from 75 up to 100% of the rated stroke stated on the actuator's nameplate. At values less than 75% the value 20 mA is reduced proportionally.

4.6.2 EPV – 3-wire version (Fig. 11)

The resistive transmitter with the converter is in the plant adjusted to have the output current signal metered on the terminals 81-82 (the wiring diagram Z257 - without power supply) as follows:

- in the position „open“ 20 mA or 5 mA, resp. 10 V
- in the position „closed“0 mA or 4 mA, resp. 0 V according to the specified version of the converter.

If the transmitter requires a new adjustment follow these steps:

- Put the actuator to the position „closed“ and switch the power supply off.
- Adjust the resistive transmitter according to the previous chapter. The resistance is to be metered on the terminals 0%-100% (Fig. 7). The used transmitter resistance is 2000W or 100 W.
- Switch the converter's power supply on. Turn the adjusting trimmer A (Fig. 7) to adjust the output current signal rate measured on the terminals 81-82.
- Set the actuator to the position „open“.
- Turn the adjusting trimmer B (Fig. 7) to adjust the output current signal rate measured on the terminals 81-82.
- Check the output signal of the converter in the both limit positions, and repeat the procedure if needed.

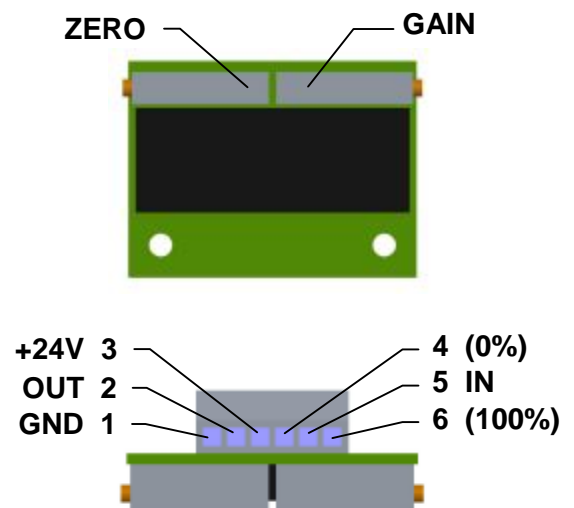

Fig.11

Note:

The output signal of (0-20mA, 4-20mA or 0-5mA, 0-10V - according to the specification) can be adjusted at the range from 85 up to 100% of the rated stroke stated on the actuator's nameplate. At values less than 85% the value of the output signal is reduced proportionally.

Note:

The output signal of 4-20mA can be adjusted at the range from 75 up to 100% of the rated stroke stated on the actuator's nameplate. At values less than 75% the value 20mA is reduced proportionally.

4.7 Adjustment of Capacitive Transmitter CPT1/A (Fig.12)

The chapter describes adjustment of the capacitive transmitter to the specified parameters (standard values of output signals) in case they are reset. The capacitive transmitter serves as a position transmitter of electric actuators with unified output signal of 4÷20 mA.

Note:

In case that reversed output signals are needed (in the position "OPEN" minimum output signal) contact personnel of service centres.

The capacitive transmitter CPT1/A is adjusted by the producer to the fixed operation angle according to the order and wired according to the wiring diagrams placed into the cover. Check the power supply of the user after connecting to terminal of the terminal board before the transmitter is electrically checked. Adjustment of the capacitive transmitter can be performed when the position switches are adjusted. The adjustment is performed with the power supply of 230 V/50 Hz and ambient temperature of $20 \pm 5^\circ\text{C}$.

The following versions of electric actuators with built capacitive transmitters can be specified:

- A) The version without any power supply (2-wire version)**
- B) The version with a power supply (2-wire version)**
- C) The version CPT as a feedback to the position controller for EA with controllers.**

A.) Adjustment of the Capacitive Transmitter without any Power Supply

Before connecting check the power supply. The measured voltage should be in range from **18 up to 28 V DC**.



The voltage of the power supply must not be in any case higher than 30 V DC. The transmitter can be irreversibly damaged!

While checking or adjusting the output signal of 4÷20 mA follow these steps:

- Connect a mA meter of precision class 0,5 and loading resistance lower than 500Ω serially with the transmitter (pole "-"; terminal 82)
- Put the actuator to the position "CLOSED", the signal value should decrease.
- Check the signal value for the position "CLOSED" (4 mA).
- Tune the signal with loosening the fixing screws (15) and turning the trimmer (10) until the required value of 4 mA is reached. Tighten the fixing screws.
- Put the actuator to the position "OPEN", the signal value should raise.
- Check the signal value for the position "OPEN" (20 mA).
- Tune the signal with turning the trimmer (20) until the required value of 20 mA is reached.
- Check the signal value for the position "CLOSED" and then for the position "OPEN".
- Repeat the procedure until the change from 4 to 20 mA is reached with deviation less then 0,5 %.
- Disconnect the meter and lock the screws with a varnish.

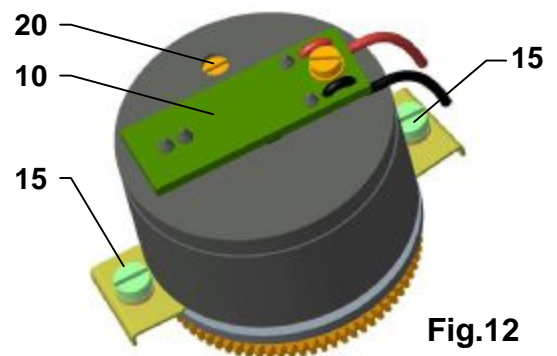

Fig.12

B.) Adjustment of the Capacitive Transmitter with the Power Supply

1.) Check the power supply: 230 V AC, resp. 24 V AC (according to version) $\pm 10\%$, on the terminals 1, resp. 60 and 61

2.) While checking or adjusting the output signal of 4÷20 mA follow these steps:

- Connect a mA meter of precision class 0,5 and loading resistance lower than 500Ω on the terminals 81, 82.
- Follow the procedure described in the previous chapter A.

C.) Adjustment of the Capacitive Transmitter Served as a Feedback of the Position Controller

While checking or adjusting the output signal of 4÷20 mA follow these steps:

- Disconnect the circuit on the terminals 81 and 82 removing the jumper.
- Connect power supply to the terminals 1 and 61.
- Disconnect the control signal from the terminals 86 and 88.
- Put the actuator to the direction "OPENING" or "CLOSING" with the handwheel or connecting power supply to the terminals 1 and 200 for the direction "OPENING", or 1 and 24 for the direction "CLOSING".
- Connect a mA meter of precision class 0,5 (e.g. digital) and loading resistance lower than 500Ω on the terminals 81,82.
- Follow the procedure for the version without any power supply described in the previous chapter A.

- Having the transmitter adjusted put the jumper again on the terminals 81 and 82 in case that the output signal wont be used (the circuit through the terminals 81 and 82 should be closed).
- Connect the control signal to the terminals 86 and 88



The user has to arrange grounding of the 2-wire circuit of the capacitive transmitter to the electrical ground of a joined controller, computer, etc. The grounding should be performed only in one place in any part of the circuit outside the electric actuator!

Note:

The trimmer (20) can be used to adjust the output signal of the capacitive transmitter to any value of Operating angle in range from ca 40% up to 100% of the value of the Operating angle adjusted by the producer and stated on the actuator's nameplate.

4.8 Adjustment of the DCPT3M transmitter

Before the transmitter **DCPT3M (Fig.13)** adjustment the position switches S3 and S4 have to be adjusted. Adjustment consists in setting of the output signal value in the limit positions of the actuator.

By default (unless determined otherwise by the customer), the manufacturer aligns the DCPT3M transmitter so that output signal value 4mA is set for the limit position "closed" and 20 mA for the position "opened". By default the characteristics of the output signal is set to 20-4 mA (ascending).

Notes 1: -this type of transmitter enables the assignment 4 mA / 20 mA of the output signal value to any limit position of the actuator.

2:-the transmitter is adjustable within the range of 35 to 100% of the full stroke specified in the nameplate. By wrong stroke adjusting (outside transmitter range), error appears (LED blinking 2-times)

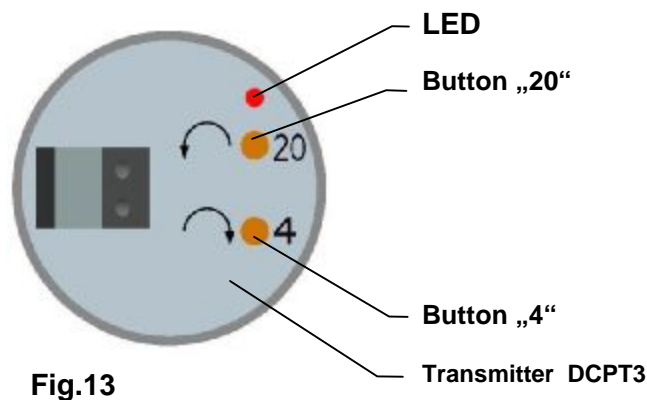

Fig.13

Setting of limit positions

If limit positions require re-adjustment, proceed as follows:

Adjustment of the "4 mA" position:

- Turn on the power supply voltage to DCPT3M
- Reset the actuator to the limit position that you want to assign 4 mA signal value to and press (for about 2 seconds) the pushbutton "4", until LED flashes

Adjustment of the "20 mA" position:

- Turn on the power supply voltage to DCPT3M
- Reset the actuator to the limit position that you want to assign 20 mA signal value to and press (for about 2 seconds) the pushbutton "20", until LED flashes

Notes 3: Transmitter error code may result when the first limit position is saved (2x LED flash). The error code is erased by saving of the second limit position, provided that the saved limit positions are within 35 to 100% of the rated stroke specified in the nameplate.

If necessary, please change the characteristic of the output signal from descending to ascending or vice versa, according to the following chapter.

Setting of the ascending/descending characteristic of the output signal

When the characteristic of the transmitter output signal is changed, the set limit positions "4 mA" and "20 mA" are maintained, however the operating range (stroke of DCPT3M) between these two positions is changed to the complement of the original operating range.

When the DCPT3M transmitter is set so that output signal value 4mA is set for the limit position "closed" and 20 mA for the position "opened", the characteristic must be set to ascending (Adjusted by producer if customer define others).

When the DCPT3M transmitter is set so that output signal value 20 mA is set for the limit position "closed" and 4 mA for the position "opened", the characteristic must be set to descending.

If you need to toggle the characteristic of the transmitter output signal 4-20 mA (ascending), or 20-4 mA (descending), please proceed as follows:

- Turn on the power supply voltage to DCPT3M
- For 4-20 mA (ascending characteristic) press the pushbutton "20" and subsequently "4" and hold both buttons pressed until LED flashes.
- For 20-4 mA (descending characteristic) press the pushbutton "4" and subsequently "20" and hold both buttons pressed until LED flashes.

Calibration MENU

- For current value increasing push and hold the button „20“ until current increase.
Longer holding The calibration menu enables setting of default parameters and calibration of current values 4 and 20 mA (fine tuning of the value of the output current signals 4 and 20 mA in the limit positions).

Calibration mode input for adjusting of output current:

- Turn off the power supply to the transmitter power supply source.
- Press and hold the "4" and "20" adjustment pushbuttons.
- Turn on the power supply to the transmitter power supply source.
- Hold both pushbuttons until the first and on to the second flash of LED.
- In this menu input is firstly adjusted for value 4 mA.

Current 4-20 mA adjusting in calibration mode:

- For current value decreasing push and hold the button „4“ until current decrease.
Longer holding of this button means autorepeat of current value. Releasing of this button means writing current value.
of this button means autorepeat of current value. Releasing of this button means writing current value.

Toggling between 4 and 20 mA in the calibration mode:

- For 4 mA press the pushbutton "20" and subsequently "4" and hold both buttons pressed until LED flashes.
- For 20 mA press the pushbutton "4" and subsequently "20" and hold both buttons pressed until LED flashes.

Restoring factory (default) settings:

Warning: Using this all adjusted parameters will be canceled and adjusted to factory settings (current calibration, positions 4 and 20 mA). Therefore it is necessary to make new transmitter calibration.

- Turn off the power supply to the transmitter power supply source.
- Press and hold the "4" and "20" adjustment pushbuttons.
- Turn on the power supply to the transmitter power supply source.
- Hold both buttons until first and second LED blink.
- Turn-off and turn-on transmitter power supply again.
- LED stays lighting and after 10 sec. go out.

Leaving calibration mode:

- After 10 sec. not working in calibration mode, LED will go out as a signal of leaving calibration mode. If LED is blining, error appears.

Transmitter errors:

In case of error LED starts blinking. Number of LED blinking means number of error in table No. 4. After longer pause blinking process repeats. In case of more errors, number of errors are blinking one after another. Longer pause between blinking separate particular errors.

Example of error number 2 and 1 according to LED blinking:



TABLE 4		
Number of blinking LED	Error	Eliminate the error
1x	Transmitter position outside operating range	- change the characteristics of the output signal, respectively. - return the actuator output member to the working area, resp. - sort the end positions of the transmitter
2x	Incorrectly set working stroke	- check the stroke adjustment range and reset the transmitter stroke.
3x	Sensor error	- change transmitter.
4x	Incorrect parameters in EEPROM	- change transmitter.

4.9 Adjustment of position controller (Fig. 14)

The built-in position controller REGADA of new generation is a user-friendly control system to control actuators with an analogue signal. The controller takes advantages of high-power RISC processor MICROCHIP to perform all functions. It provides also continuous automotive diagnostics of the system, error messages as well as number of relay switching and number of controller's operation hours. Placing an analogue signal onto the input terminals of the terminal board 86/87 (GND, -) and 88 (+) causes that the EA output is reset.

Required parameters and functions can be programmed using function buttons SW1 - SW2 and LED diodes D3 - D4 placed directly on the controller, see Table 5.

4.9.1 Setting of controller

The controller's microprocessor unit is in the production plant programmed to parameters given in **Table 5** (Note 2).

Setting of the controller is performed using buttons and LED diodes.

Adjust the position and torque switches and the position transmitter before adjustment of the controller.

Laying of adjusters and signaling elements on the board of the REGADA controller is shown on Fig. 14:

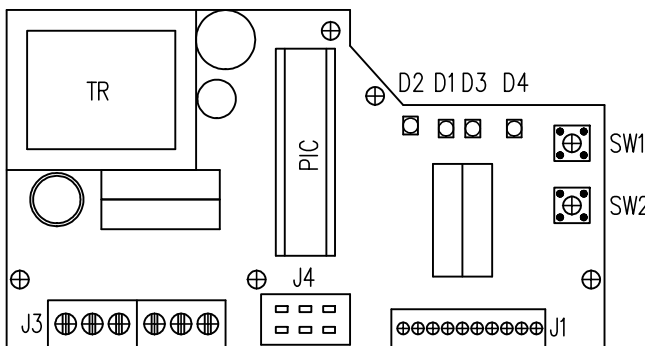

Fig.14

SW1 button	starts an initialization routine an allows listing in the adjust menus
SW2 button	setting of parameters in the chosen menu
D1 diode	power on indication
D2 diode	motion to the direction "opening" indication (green) - "closing" (red) indication
D3 diode	(yellow light) number of blinking codes indicates chosen adjust menu
D4 diode	(red light) number of blinking codes indicates adjusted parameter of the controller from the chosen menu

Table 5:

D3 (yellow) diode number of blinking	Adjust menu	D4 (red) diode number of blinking	Adjusted parameter
1 blink	control signal	1 blink	0-20mA
		2 blinks	4-20 mA (*) (**)
		3 blinks	0-10V DC
2 blinks	response for signal SYS-TEST	1 blink	EA opens receiving signal SYS
		2 blinks	EA closes receiving signal SYS
		3 blinks	EA stops receiving signal SYS (*)
3 blinks	mirroring (ascending/descending characteristics)	1 blink	EA CLOSING at increasing of control signal
		2 blinks	EA OPENING at increasing of control signal (*)
4 blinks	insensitiveness of controller	1 to 10 blinks	insensitiveness of controller of 1-10% (3% set by the producer) (*)
5 blinks	way of regulation	1 blink	narrow torque
		2 blinks	narrow position (*)
		3 blinks	wide torque
		4 blinks	wide position

Notes:

1. The controller at autocalibration automatically sets the feedback type - resistant/current
2. (*) Parameters set in the production plant, if customer has not stated else.
3. (**) Input signal
4 mA - position "closed"
20 mA - position "open"

Standard setting of controller (programmed RESET of controller) - in case of any problems with setting of the parameters it is possible with pressing both **SW1** and **SW2** at the same time and then switching power on to set the standard parameters.

Controller setting procedure:

The initialization routine starts at the switched-on controller, zero system deviation and short pressing of the SW1 button for ca 2 sec (i.e. until the diode D3 got on). Loosing the button some of the default menus starts (usually control signal) what is shown with 1 blink on the D3 diode as well as one of the default parameters (usually control signal of 4-20mA) what is shown with 1 blink on the D4 diode. Then the required parameters of the controller can be changed according to Table 5:

- press shortly the SW1 button to list the menu shown with the blinking number on the D4 diode.
- press shortly the SW2 button to set parameters shown with the blinking number on the D4 diode.

After changing of the parameters according to user's wishes, put the controller to autocalibration with pressing the SW1 button for ca 2 sec (i.e. until the diode D3 got on). During this process the controller performs the feedback transmitter and turning sense checking, sets actuator to the positions "open" and "closed", measures inertia mass in the directions "opening" and "closing", and loads the adjusted parameters into the EEPROM memory. In case that during the initialization process an error occurs (e.g. in connection or adjustment) the initialization process will be interrupted and the controller with the D4 diode reports about the type of the error. Else after finishing the initialization process the controller is put into the regulation mode.

Error messages of the controller with D4 diode at initialization

4 blinks.....improper connection of the torque switches

5 blinks.....improper connection of the feedback transmitter

8 blinks.....bad sense of actuator's turning direction or adverse connection of the feedback transmitter

4.9.2 Watching operation and error states

Watching operation and error states is possible with the EA open.

a) Operation status with the D3 LED diode indicating:

- it is continuously lighting - the controller regulates
- it is continuously not lighting - system deviation in the insensitiveness range - the EA has stopped

b) Error state with the D4 and D3 LED diodes indicating - D4 continuously lighting, D3 indicates error state with blinking

1 blink (repeated)	indication of the "TEST" mode - the EA is put to the position according to the signal in the "TEST" menu (at connecting the 66 and 86/87 terminals)
2 blinks (repeating after short pause)	missing of control signal - the EA is put to the position according to the signal in the "TEST" menu
4 blinks (repeating after short pause)	torque switches activity indication (the EA switched-off with the torque switches in a mid-position)
5 blinks (repeating after short pause)	failure of the feedback transmitter - the EA is put to the position according to the signal in the "TEST" menu
7 blinks (repeating after short pause)	control signal (current at range 4-20mA less than 4mA (3.5mA)).

4.10 Electric local control (Fig.15)

-additional equipment

If necessary (accession, function check and so on), it is possible to preset EA by local electric control with secured power feeding. Upon switching the local control to "LOCAL" mode, it is possible to use OPEN and CLOSE buttons to control the movement of the output element in the entered direction. LEDs indicate individual modes of the local control.

The control is possible after removing the padlock (1). Control mode selection is changed by sequential pressing of the button (2) **REMOTE-OFF-LOCAL** to "Remote" "Shut off", "Local", "Shut off". Individual modes are cycled by sequential pressing. The selection is indicated by LEDs visible on the front panel of the local control.

LEDPWR (6) indicates the presence of supply voltage to control the local control.

Individual local control modes:

The „OFF“ mode - this mode does not enable remote or local control of EA. The mode is indicated by LEDs **REMOTE** (7) and **LOCAL** (8) being off

The „LOCAL“ mode - this mode enables EA control in the open and close direction and to stop using buttons **OPEN** (3) (open), **CLOSE** (4) (close) and **STOP** (5). The „LOCAL“ mode is indicated by **LOCAL** (8) LED being lit. When **OPEN** button is pressed in this mode, it is indicated by **OPEN** LED being lit (9). When **CLOSE** button is pressed in this mode, it is indicated by **CLOSE** LED being lit (10). When **STOP** button is pushed, the signal LEDs **OPEN** (9) and **CLOSE** (10) are switched off.

The „REMOTE“ mode - in this mode the EA can be remotely controlled by commands from master system. The „REMOTE“ mode is indicated by **REMOTE** (7) LED being lit. In this mode the OPEN, STOP and CLOSE buttons are not functional.

After finishing the work with electrical local control, we recommend to return the padlock to button (2) in mode „REMOTE“ and lock out the device to avoid unwanted tampering by unauthorized person.

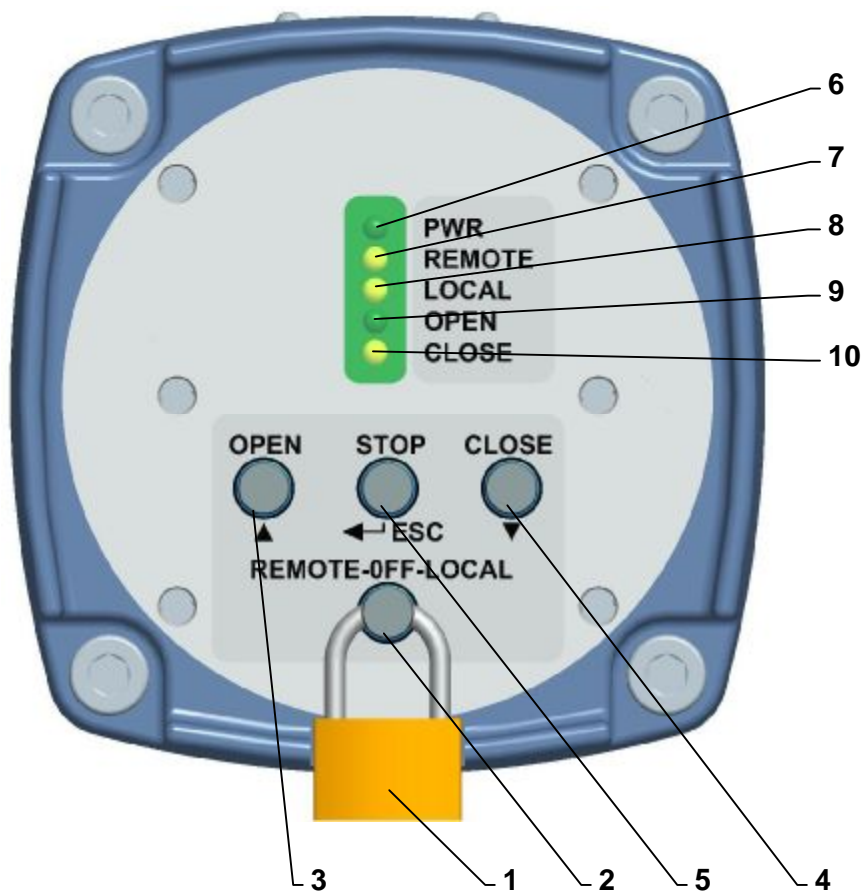

Fig. 15

5. Service and Maintenance

5.1 Service



1. *In general it is supposed that the EA is serviced by a qualified person as required in the Chapter 1!*
2. *After the EA is put into operation it is necessary to check whether during manipulation its surface finishing was not damaged – the damages should be eliminated to prevent the surface against deterioration caused by corrosion!*

- The EA **UM 2** requires just an insignificant service. The reliable operation is determined by the correct putting into operation.
- The service of the EA results from the operation conditions and generally consists in treating the information for subsequent performing of a required function. The EA can be controlled by remote control electrically or manually on the place of their installation. The manual control is available with a hand wheel.
- The service staff should arrange the required maintenance and prevent the actuator during operation against impacts of environment and climate what exceed the frame of allowed influences stated in the Chapter "Operation Conditions".
- It is necessary to avoid overheating of the EA surface, exceeding of parameters stated on the nameplate and abnormal vibrations of the EA.

Manual control:

- If the manual control is needed (adjustment, function checking, failures etc.) the staff can reset the regulated member using the handwheel. While rotating the handwheel clockwise the output element moves in the direction "CLOSING".

5.2 Maintenance - extent and periodicity

During inspections and maintenance is needed to tighten all screws and nuts that affect the tightness and coverage. Similarly, once a year should be checked and if necessary tighten mounting screws of the terminal wires and assuring of the slip-on joints with wires.

The interval between two preventive inspections is four years.

The replacement of cover gaskets and gasket of an oil filling is needed in case of damage or after 6 years of the operation.

The grease in the supplied actuators is designed for the lifetime of the product.

It is not necessary to change the grease during the operation of the actuator.

During inspection, replace the sealing O-ring (see Chapter 6) between the bottom and top cover - replace with original O-ring from manufacturer.

Lubrication:

- the gearbox and drive mechanism on the control board - grease:
 - in versions with temperatures -25°C till +55°C - grease μ HF 401/0, resp. GLEITMO585
 - in versions with temperatures -50°C till +40°C - grease ISOFLEX TOPAS AK 50
 - in versions for climate with temperatures -60°C till +40°C grease DISCOR R-EP 000.



Lubrication of the valve stem is independent on maintenance of the EA!

After every potential flooding of the product check, whether there is no water inside. After eventual water penetration, dry the product before repeated putting into operation and replace damaged sealings, resp. other parts of EA. identically check also tightness of cable bushings and replace them, if they are damaged.

- Every six months it is recommended to perform one check move in frame of adjusted operation stroke to verify reliability of functioning with setting back to the original position.
- If the audit rules do not determine else the inspection of EA is performed ones a year and tightening of all connecting and grounded screws have to be checked to avoid overheating.
- After 6 months from putting of EA into operation and once a year it is recommended to check tightening of fixing screws between the EA and the valve. (Tighten the screws with the cross system.)

- While connecting and disconnecting of the EA check the tightness of cable glands – those with damaged sealings should be replaced by new ones of the approved type!



Keep the EA clean and take care about removing impurities and dust. The cleaning has to be performed regularly according to the operation possibilities and requirements.

5.3 Troubleshooting

- In case of a mains failure the EA stands in the position where it was before the failure occurred. If needed the EA can be reset using the manual control (with the handwheel). When necessary EA can be manually operated (hand wheel), at doing this, pay attention to keep the movement of the EA output part within the range of the set stroke so as to avoid losing the adjustment of the limit position switches or position transmitter or regulator. After supply voltage recovery EA is prepared for operation.
- In case of a failure of a part of the EA the part can be replaced by a new one. The exchange is to be committed by the producer or a contracted service firm.
- In case of an EA failure, which cannot be eliminated directly in operation, follow instructions for under-guaranty and after-guaranty service.

Table 7

Failure	Cause	Troubleshoot
There are no revolutions of motor rotor when operating the push-buttons.	1. No voltage on the electric motor connectors.	Check connection and voltage presence.
	2. No voltage on the control part.	Check connection of the control part.
The EA fails to stop at the limit positions.	1. Incorrect setting-up of the switches.	Perform adjustment.
	2. The microswitch is defective	Replace the microswitch for a new one and adjust.
	3. Incorrect actuator connection	Check connection of position and torque switches in control circuit.
The EA stops at the mid-position.	There is an obstacle in the valve or part of it seizes.	Perform reversing of the EA, move it to the original direction and, in the case that the failure repeats, repair the armature.
There is no indication of reaching these positions in the final positions.	1. The LEDs fail to operate.	Replace the LEDs for new ones.
	2. Incorrect adjustment of the position signal switches.	Adjust the position signal switches.
		In case that some EA failures still remain, contact the service centres.

Note: If the EA has to be dismantled follow the procedure of the Chapter "Dismantling"



The EA can be dismantled to be repair purpose by qualified and trainer persons only! The training can be preformed by the producer or by a contracted service firm.

6. Accessories and Spare Parts

As accessories the **handwheel** is packed with the product.

6.1 List of the Spare Parts

Table 8: Spare Parts

Spare part	Order Nr.	Position	Figure
Electric motor; 100 W; 24 VAC;	63 592 XXX	2	1a
Electric motor 120 W/228VA; 120 V AC, 60 Hz;	63 592 XXX	2	1a
Electric motor; 120 W/228VA; 230V AC	63 592 394	2	1a
Electric motor r; 180 W; 3x400V AC; 3x415	63 592 330	2	1a
Capacitor 8 μ F	Electric motor components	2	1,1a
Microswitch CHERRY DB 6G-A1LB	64 051 466	26,27	8
		-	2,6
Capacitive transmitter CPT 1	64 051 499	10	12
Resistant wire transmitter (potentiometer) RP19; 1x100	64 051 812	5	9
Resistant wire transmitter (potentiometer)RP19; 1x2000	64 051 827	5	9
Resistant wire transmitter (potentiometer)RP19; 2x100	64 051 814	5	9
Resistant wire transmitter (potentiometer)RP19; 2x2000	64 051 825	5	9
Transmitter DCPT3M	64 051 059	-	13
Power supply DX3004.P24	64 051 184	-	1
Ringlet 202,79x3,53 AS 568 B/BS 1806	62 732 156	-	-
Ringlet 105x3 MVQ (local control)	62 732 390	-	-



The disassemble of EA for the purpose of repair is possible only for the manufacturer!

7. Enclosures

7.1 Wiring diagrams UM 2

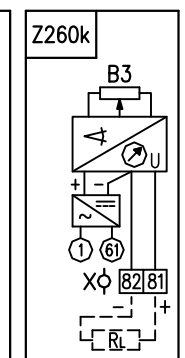
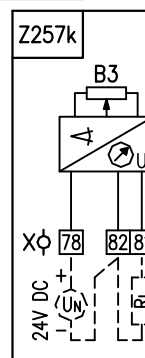
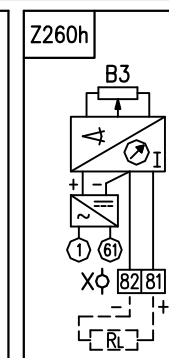
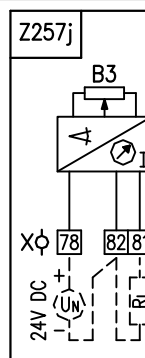
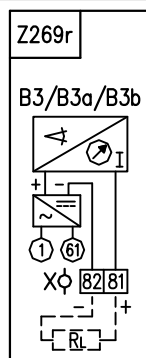
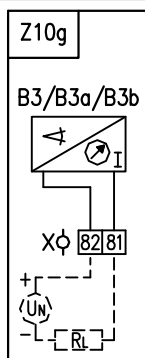
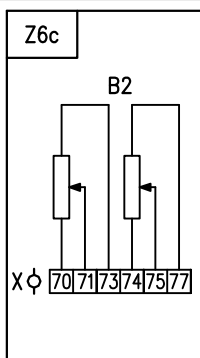
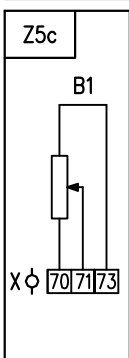
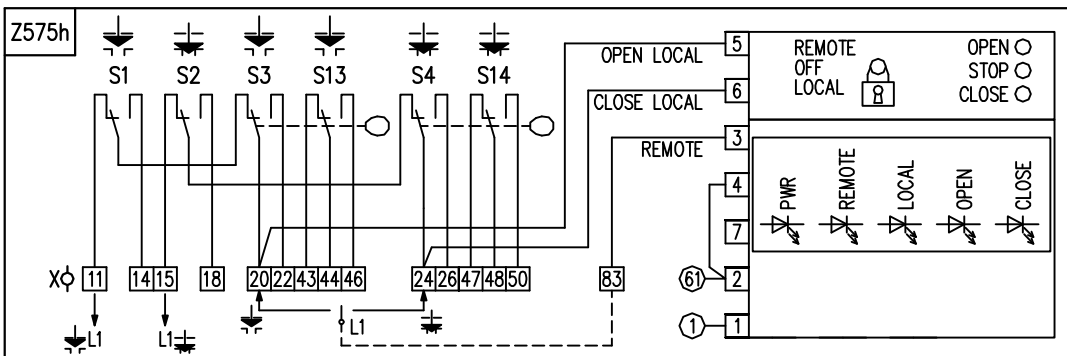
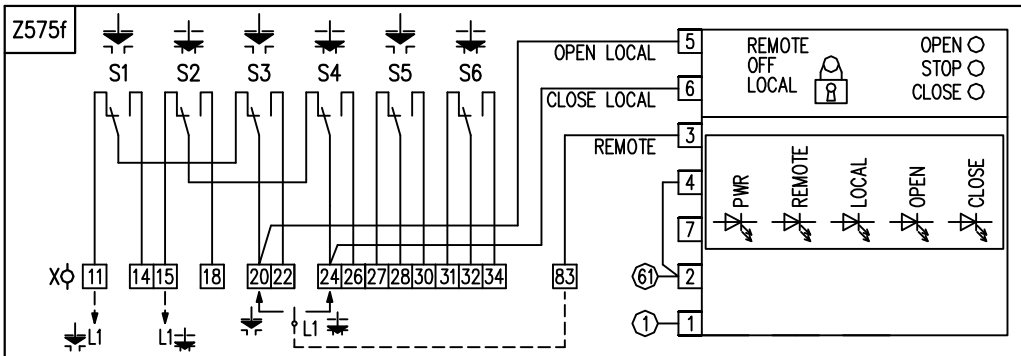
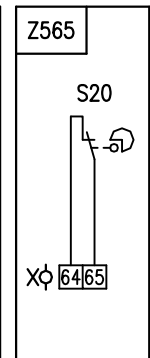
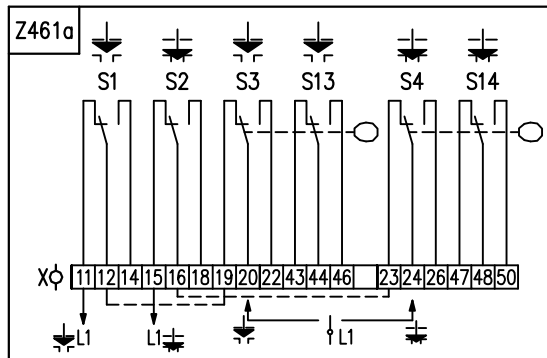
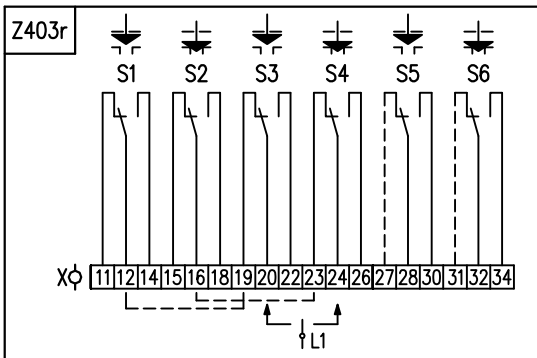
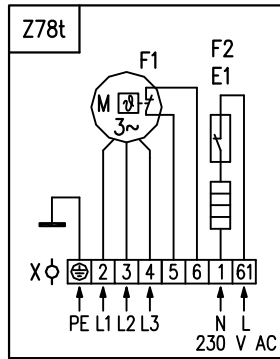
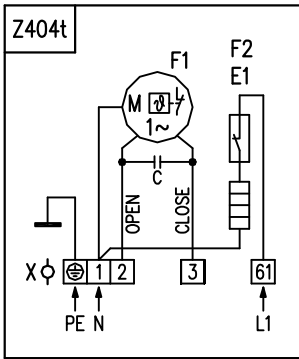

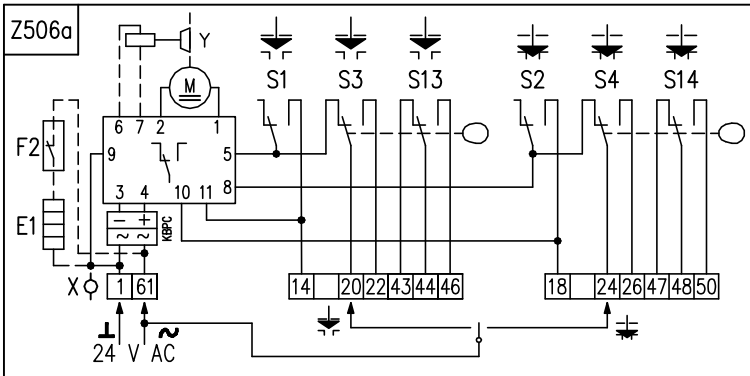
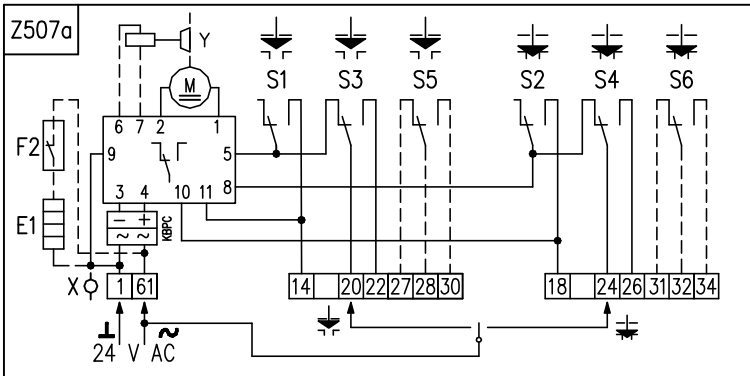
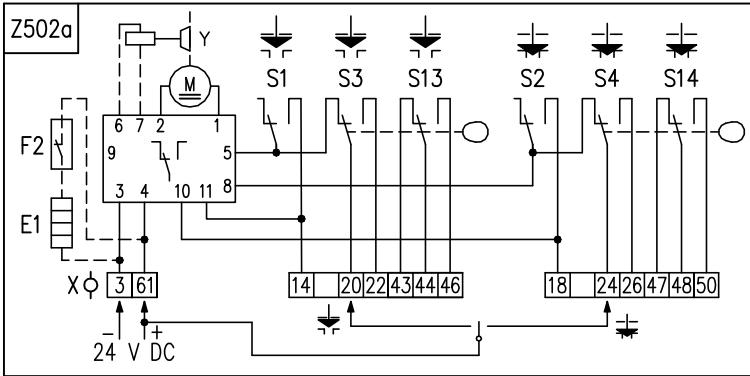
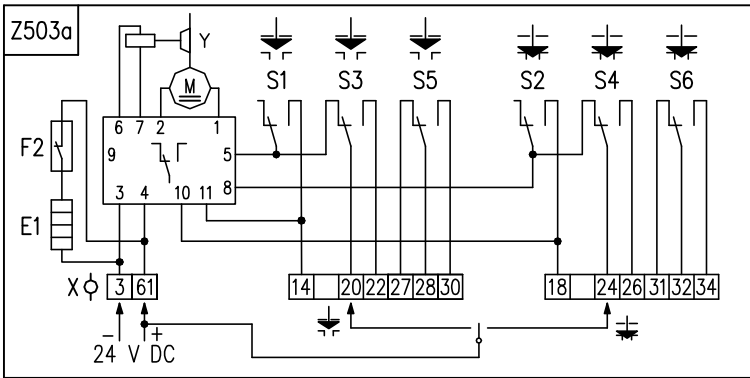

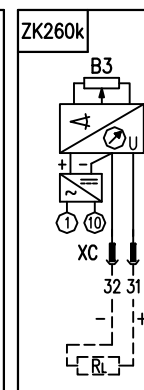
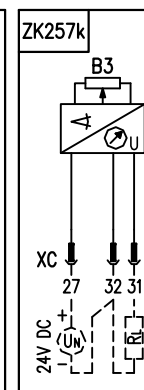
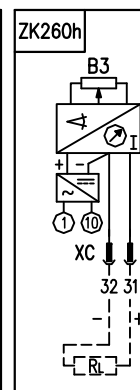
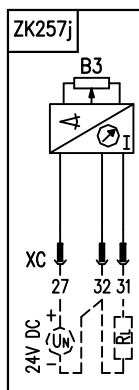
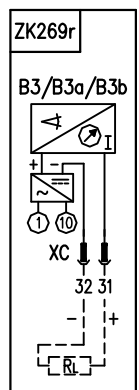
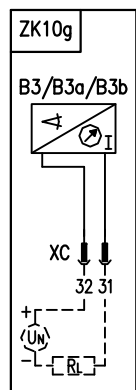
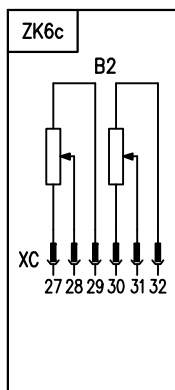
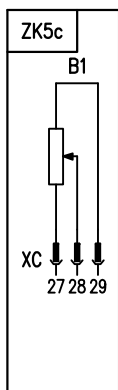
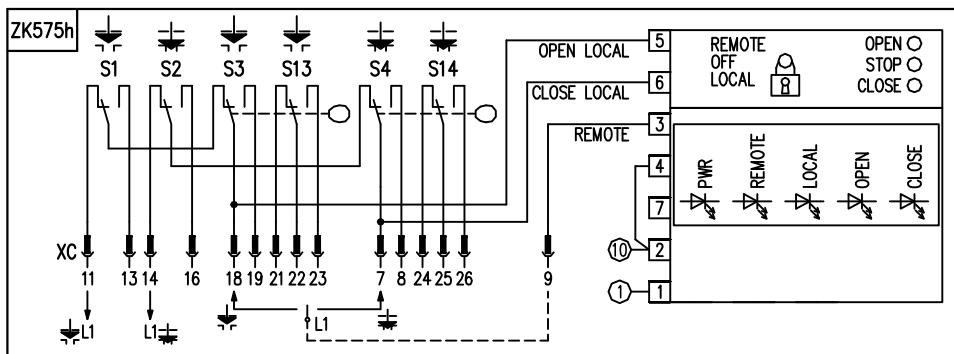
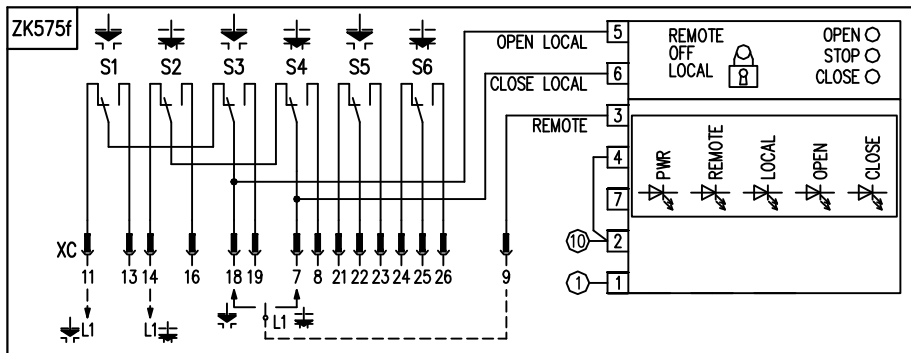
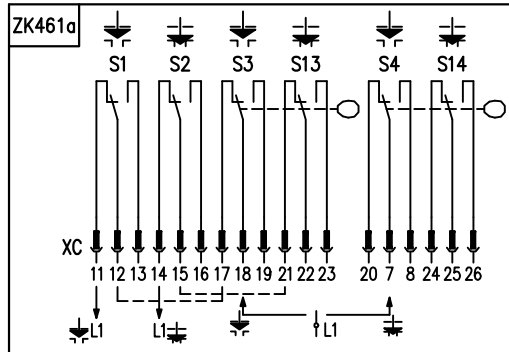
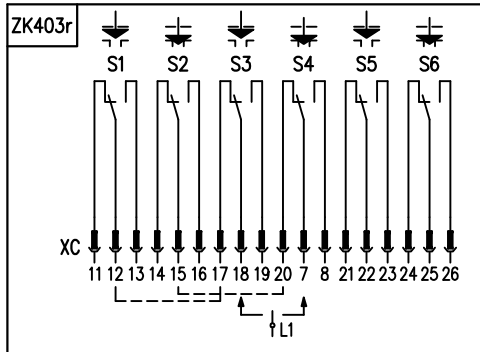
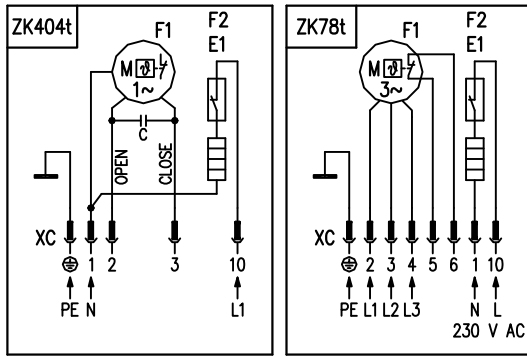

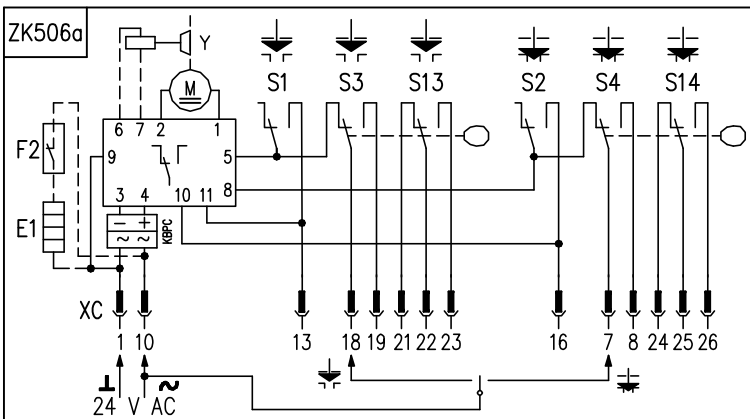
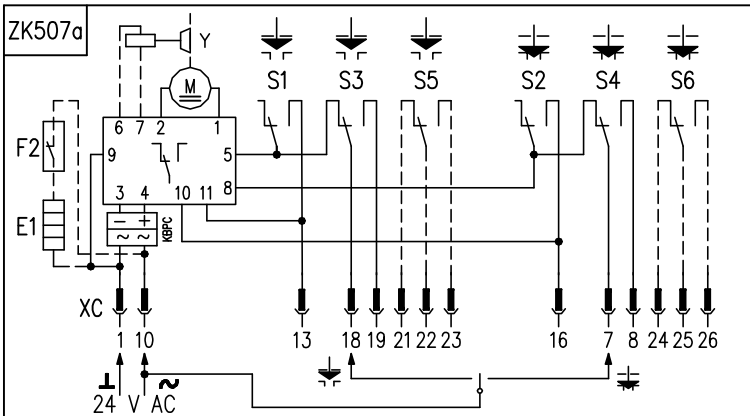
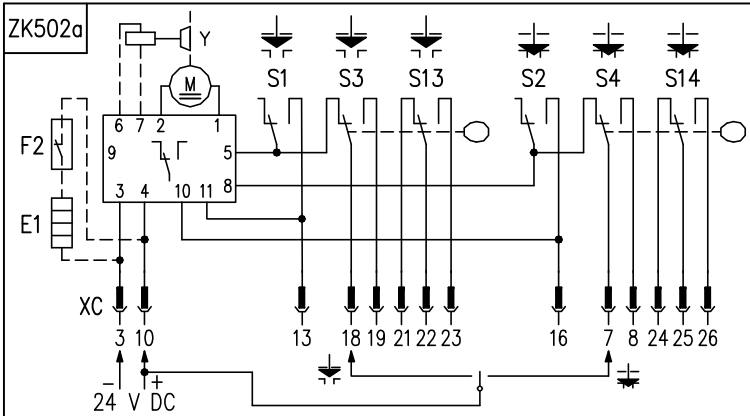
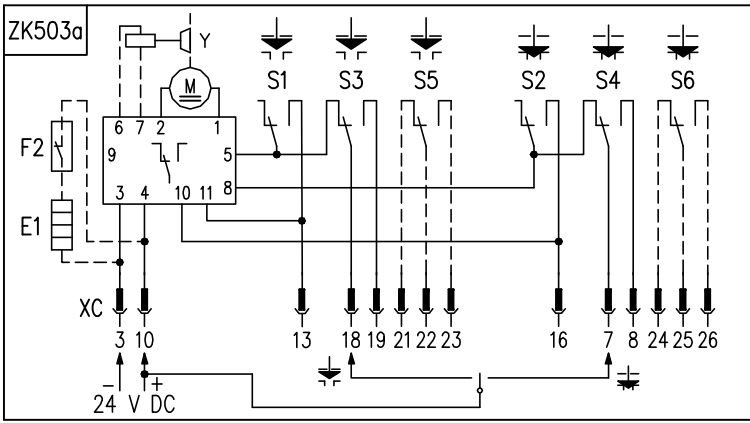

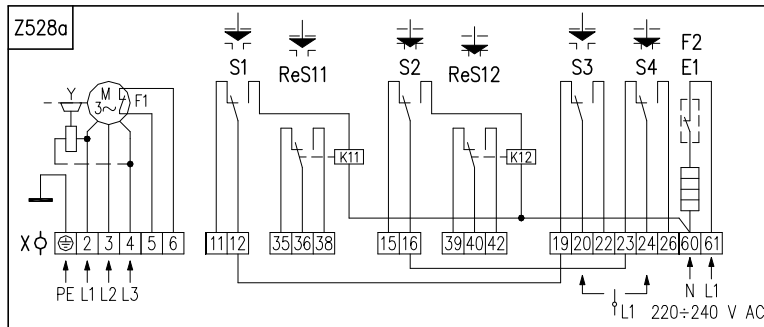
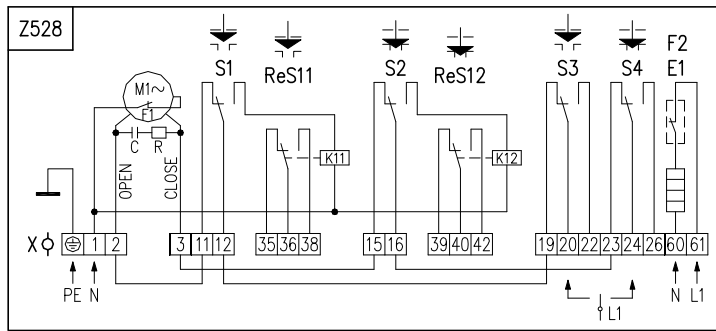

Legend:

The legend to the wiring diagrams Zxxx (eg Z5c) with terminal board connection is identical with wiring diagrams with connection to connector ZKxxx (eg ZK5c).

- Z5c..... wiring diagram of single resistant transmitter
- Z6c..... wiring diagram of double resistant transmitter
- Z10g..... wiring diagram of resistive with current converter or capacitive transmitter or DCPT transmitter 2-wire without supply
- Z78t..... wiring diagram of 3-phase electric motor and space heater
- Z257j..... wiring diagram of resistive transmitter with current converter – 3-wire without power supply
- Z257k..... wiring diagram of resistive transmitter with voltage converter – 3-wire without power supply
- Z260h..... wiring diagram of resistive transmitter with current converter – 3-wire with power supply
- Z260k..... wiring diagram of resistive transmitter with voltage converter – 3-wire with power supply
- Z269r..... wiring diagram of resistive with current converter or capacitive transmitter or DCPT transmitter 2-wire without supply
- Z403r..... wiring diagram of torque and position switches
- Z404t..... wiring diagram of the EA with 1~ phase electric motor
- Z461a..... connection of torque and position switches with tandem position switches
- Z503a..... wiring diagram of EA with electric motor 24 V DC
- Z507a..... wiring diagram of EA with electric motor 24 V AC
- Z528..... wiring diagram of 1-phase electric motor and space heater torque and position switches and relay of torque (customer version)
- Z528a..... wiring diagram of 3-phase electric motor and space heater torque and position switches and relay of torque (customer version)
- Z565..... connection of flashing indicator
- Z575f..... wiring diagram of torque and position switches and local control.
- Z575h..... wiring diagram of torque and position switches with tandem position switches with electric local control

- | | |
|---|--|
| B1.....resistive transmitter (potentiometer) single | S2.....torque switch "closed" |
| B2.....resistive transmitter (potentiometer) double | S3.....position switch "open" |
| B3.....electronic position transmitter (EPV) | S13.....tandem position switch "open" |
| B3a.....capacitive transmitter | S4.....position switch "closed" |
| B3b.....DCPT transmitter | S14.....tandem position switch "closed" |
| C.....capacitor | S5.....additional position switch "open" |
| E1.....space heater | S6.....additional position switch "closed" |
| F1..... electric motor thermal protection | ReS11.....relay of torque of switch S1 |
| F2..... space heater thermal switch | ReS12.....relay of torque of switch S2 |
| I/U.....output current (voltage) signal | U _Npower supply |
| M.....electric motor | X, X2.....terminal board |
| R _L loading resistor | XC.....connector (is not valid for these types EA) |
| S1..... torque switch "open" | Y.....brake of electric motor (valid for UP 2) |

Note 1: Thermal protection of single-phase electric motor (Z404t) is standardly built-in in electric motor, on the neutral wire.

Note 2: Torque switching is not fitted with mechanical interlocking device.

7.2 Operation Logic Diagram of switches and relays

Switch	Terminal Nr.	connector pin number XC	open		closed	
S1	11 - 12	11 - 12			Operating stroke	
	12 - 14	12 - 13				
S2	15 - 16	14 - 15				
	16 - 18	15 - 16				
S3	19 - 20	17 - 18				
	20 - 22	18 - 19				
S4	23 - 24	20 - 7				
	24 - 26	7 - 8				
S5	27 - 28	21 - 22				
	28 - 30	22 - 23				
S6	31 - 32	24 - 25				
	32 - 34	25 - 26				
S13	43 - 44	21 - 22				
	44 - 46	22 - 23				
S14	47 - 48	24 - 25				
	48 - 50	25 - 26				

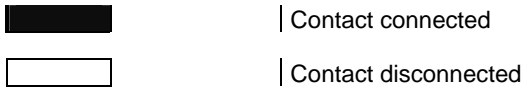

7.3 Dimensional drawings

Electric multi-turn actuators Unimact **UM 2** – flange connection ISO 5210

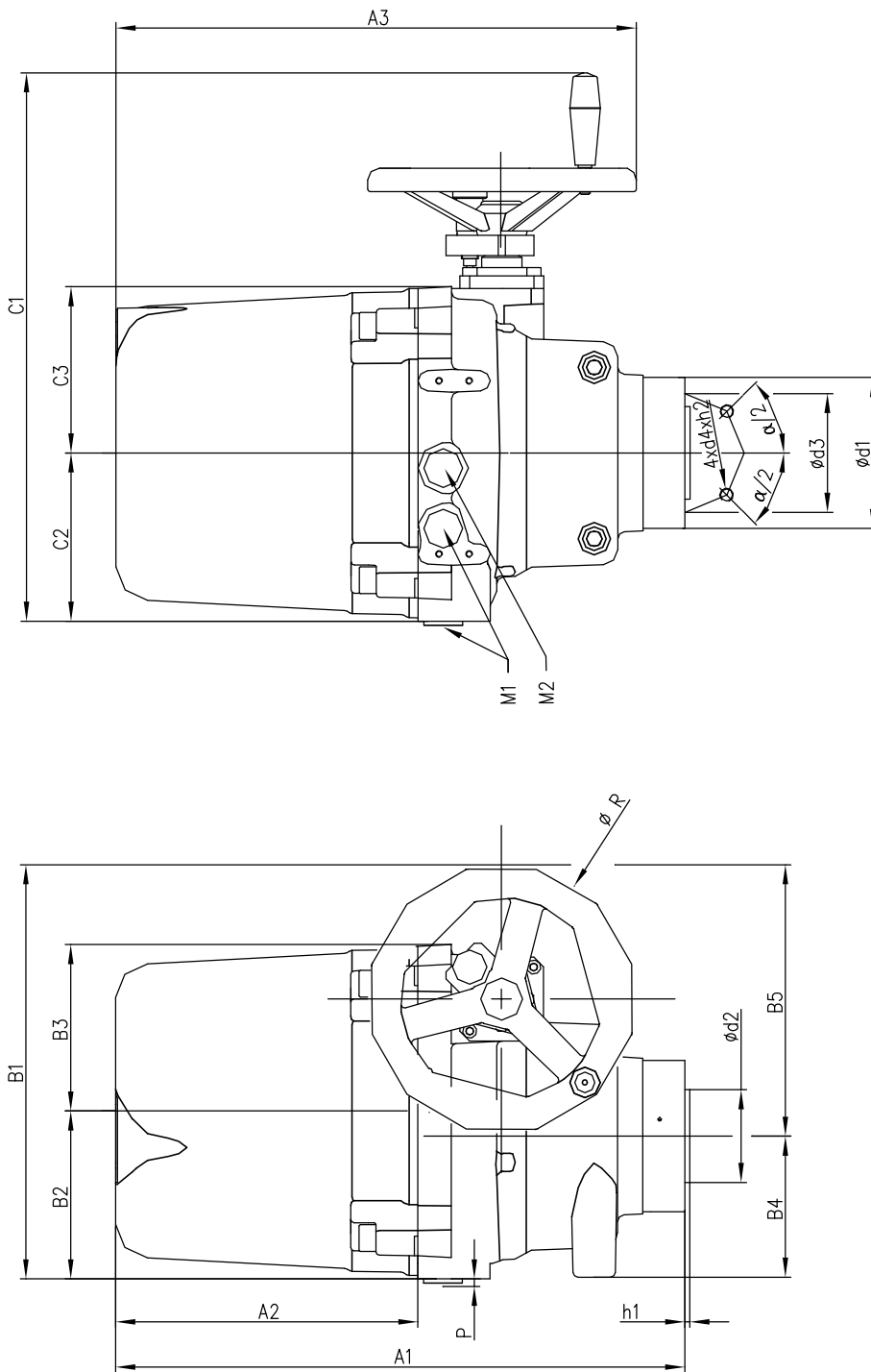

Главне голмеру / Основные голмеры / Main dimensions

	A1	A2	A3	B1	B2	B3	B4	B5	C1	C2	C3	M1	M2	P	R	$\alpha/2$	d1	d2	d3	d4	h1	h2	
UM 1	F05	354	180	310	247	100	99	84	162	326	100	98	M20x1.5	M20x1.5	4.5	160	45°	90	–	50	M6	–	20
	F07	339																		70	M8	–	16
UM 2	F07/F10	408	220	380	295	115	112	91	195	376	115	113	M20x1.5	M20x1.5	4.5	200	45°	120	–	70/102	M8/M10	–	16/20

P-2136

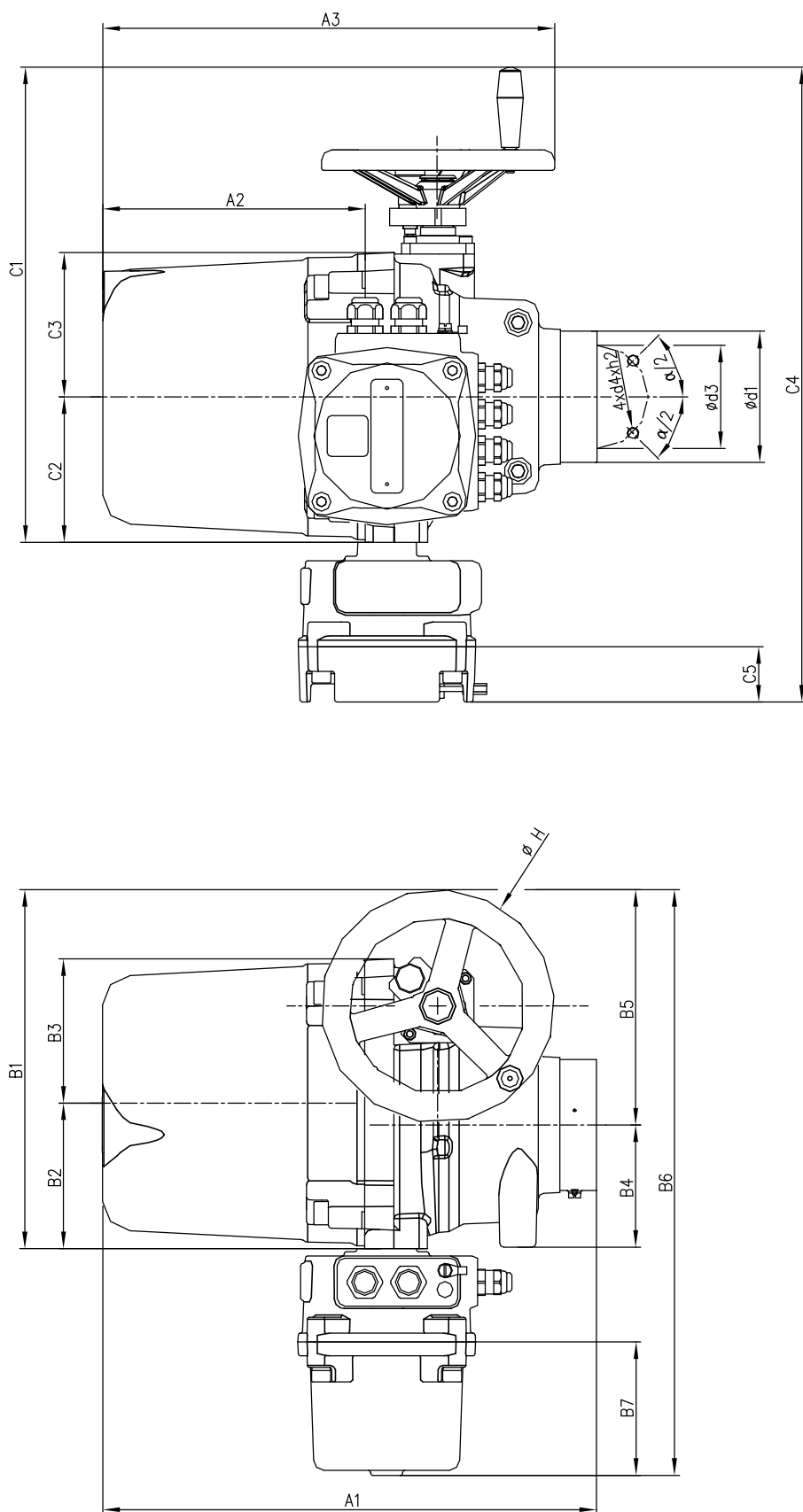

Главные размеры / Основные размеры / Main dimensions

	A1	A2	A3	B1	B2	B3	B4	B5	B6	B7	C1	C2	C3	C4	C5	$\alpha/2$	d1	d3	d4	h2	
UM 1	F05	354	180	310	247	100	99	84	162	402	92	326	100	98	436	38	45°	90	50	M6	20
	F07	339															70	70	M8		
UM 2	F07/F10	408	220	380	295	115	112	91	195	450	92	376	115	113	485	38	45°	120	70/102	M8/M10	16/20

7.4 Guarantee service check report

Service center:	
Date of repair:	Guarantee repair no.:
User of actuator:	Claim applied by:
Actuator type number:	Actuator production number:
Product claim fault:	Detected product fault:
Used spare parts:	
Remarks:	
Issued on a day:	Signature:

7.5 Post guarantee service check report

Service center:	
Date of repair:	
User of actuator:	Actuator operating place :
Actuator type number:	Actuator production number:
Detected product fault:	
Used spare parts:	
Remarks:	
Issued on a day:	Signature:

7.6 Commercial representation

Slovak Republic:

Regada, s.r.o.,
Strojnícka 7,
080 01 Prešov
Tel.: +421 (0)51 7480 460,
Fax: +421 (0)51 7732 096,
E-mail: regada@regada.sk