



INSTALLATION, SERVICE AND MAINTENANCE INSTRUCTIONS



Electric linear actuators UL 0, UL 1, UL 2

TEST CERTIFICATE

ELECTRIC LINEAR THRUST ACTUATOR UL 0, UL 1, UL 2	
Type number	Power supply V Hz
Serial number	Switching-off thrust N
Production year	Set switching-off thrust N
Wiring diagram	Operating speed mm/min
.....	Stroke mm
.....	Transmitter
Warranty period months	Input operating signal
Serial number of electric motor	
Serial number of transmitter	
Serial number of position controller	
Tests made by	
Date	Signature and stamp

COMPLETENESS CERTIFICATE

Used valve	
Assembled by: Firm	
Name	
Warranty period months	
Date	Signature and stamp

INSTALLATION CERTIFICATE

Location	
Installed by: Firm	
Name	
Warranty period months	
Date	Signature and stamp

Please read these instructions carefully before mounting and operating the actuator!

Contents

1. General data	2
1.1 Purpose and applications	2
1.2 Safety instructions	2
1.3 Product influence to environment.....	2
1.4 Data specified on electric actuator	2
1.5 Instructions for stuff training	3
1.6 Warning for safety use	3
1.7 Warranty conditions.....	4
1.8 Under-guarantee and after-guarantee service	4
1.9 Operation conditions	4
1.10 Packing, transport, storing and unpacking	6
1.11 Assessment of the product and packaging and removal of contamination.....	7
2. Description, function and specifications	7
2.1 Description and function.....	7
2.2 Basic specifications	9
3. Installation and dismantling of actuator	16
3.1 Installation	16
3.2 Dismantling.....	18
4. Adjustment.....	18
4.1 Adjustment of the Thrust Unit.....	18
4.2 Adjustment of position-signalling unit.....	19
4.3 Adjustment of resistant transmitter (Fig.4)	25
4.4 Adjustment of the Electronic Position Transmitter (EPV) - the Resistive Transmitter (Potentiometer) with the Converter	26
4.5 Adjustment of Capacitive Transmitter CPT1/A (Fig.7)	27
4.6 Adjustment of the DCPT3M transmitter	28
4.7 Electric local control (Fig.15)	31
5. Service and Maintenance	32
5.1 Service.....	32
5.2 Maintenance - extent and periodicity	32
5.3 Maintenance to assure protection	33
5.4 Troubleshooting.....	33
6. Accessories and Spare Parts	34
6.1 List of the Spare Parts.....	35
7. Enclosures.....	36
7.1 Wiring diagrams UL 1, UL 2	36
7.2 Wiring diagrams UL 0.....	40
7.3 Operation Logic Diagram of switches and relays.....	42
7.4 Dimensional drawings	43
7.5 Guarantee service check report	56
7.6 Post guarantee service check report.....	57
7.7 Commercial representation	58

The Installation, Service and Maintenance Instructions are drawn up according to requirements of EC Executive Nr. 89/392/EEC "Uniform requirements for machines and devices from the point of view of safety and health care", to save life and health of users and to avoid material damages and exposure environment to danger.

1. General data

1.1 Purpose and applications

Electric linear actuators (hereinafter EA) types **UL 0, UL 1, UL 2** are high-powered electric-mechanical products, designed for direct installations onto controlled devices (regulating bodies -valves, etc.). EA of **UL 0, UL 1, UL 2** types are provided for remote control of closing bodies, and EA with controller for automotive control of regulating bodies in both directions of their movement. They can be equipped with means of measuring and control of technological processes where an unified analogue direct current or voltage signal is an information bearer on their input and/or output. They can be used in heating, energy, air-conditioning and other technological systems, which they are suitable for, regarding their features. They are connected with controlled devices with a flange according to, EN 15714-2 or using a pillars and flanges.



1. **It is forbidden to use EA as a lifting mechanism!**
2. **Switching of actuator by a semiconductor switches have to be consulted with producer.**

1.2 Safety instructions

Product characteristics from risk point of view

EA are reserved technical devices with higher rate of danger (group A), with possibility of installation in areas specially danger regarding casualties caused by electric current. EA are according to directive LVD 2014/35/EU and standard EN/IEC 61010-1 within valid edition assigned for installation category II (overvoltage category), pollution degree 2.

In order to demonstrate the compliance with the requirements of the European Council directive on machinery 2006/42/EC, European Parliament and Council Directive **2014/34/EU** on equipment and protective systems intended for use in potentially explosive environment (designated as Directive ATEX 100a), directive of the Council 2014/35/EU on LVD and Council Directive 2014/30/EU on EMC, the electric actuators are subject to certification by authorized certification facilities.

The product meets the essential safety requirements according to EN 60204-1 and is in compliance with EN 55011/A1 within valid edition.



A are reserved technical devices with higher rate of danger, with possibility of installation in areas specially danger regarding casualties caused by electric current.

1.3 Product influence to environment

Electromagnetic compatibility (EMC): the product complies with the requirements of the Directive 2014/30/EU of the European Parliament and of the Council on the approximation of the laws the Member States relating to the electromagnetic compatibility and with the requirements of standards as well EN/IEC 61000-3-3 and EN/IEC61000-3-2 within valid edition.

Vibrations caused by the product: product influence is negligible.

Noise produced by the product: The maximum allowable noise level (A) of the product measured in a place of operation is max. 62 dB (A) (to UL 0,), max.. 75 dB (A) (to UL 1) and max. 80 dB (A) (to UL 2).

1.4 Data specified on electric actuator

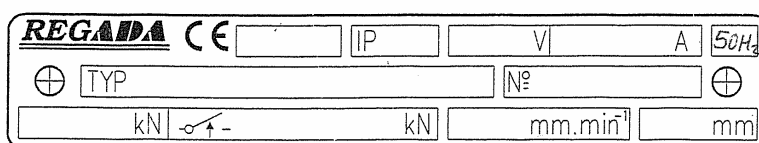

Nameplate for UL 0



Warning plate:







Nameplate for UL1 and UL 2

⊕	REGADA	TYP	№	
		 kN	mm.min ⁻¹	IP ⊕
CE	Made in Slovakia	 mm	V	A

Nameplate contains the basic data concerning identification, performance and electricity: indication of producer, type, serial number, max. load thrust and switching-off thrust, operating speed, protection code, operating stroke, supply voltage and current.

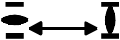
Graphic symbols on electric actuator

The graphic symbols used on electric actuator substitute the text messages. Some of them are in accordance with EN ISO 7010, ISO 7000 and IEC 60417 within valid edition.

	Dangerous voltage	(EN ISO 7010-W012)
	Stroke of the electric	
	Switching-off thrust	
	Manual control	(0096 ISO 7000)
	Protection terminal	(5019 IEC 60417)

1.5 Instructions for stuff training**Requirements for specialized skills of persons performing assembly, operation and maintenance**

Electric connection can be performed only by an acquainted person, i.e. an electrical engineer with professional education of electrical engineering at an apprentice school or a technical school (secondary, complete secondary or university education) and whose qualification was verified by an educational facility authorised to verify professional qualification.



Service can be performed only by workers professionally qualified and trained by the producer or contracted service centre!

1.6 Warning for safety use

1. Products are assigned for operation in environment consist of gas, steam and vapours, with temperature range: -25°C to $+55^{\circ}\text{C}$ or -50°C to $+40^{\circ}\text{C}$ or -60°C to $+40^{\circ}\text{C}$, with pressure range from 0.8 to 1.1 bar.
2. If the actuator is placed on device which regulate medium with higher temperature than $+55^{\circ}\text{C}$, protect the actuator by additional construction in order to maintain ambient temperature max. $+55^{\circ}\text{C}$ and also to stop temperature transmitting through junction component!
3. Cable glands blinds are assigned only for transport and storage period, i.e. for period till the actuator is builded into operation, than blinds must be replace by connecting cable.
4. In the case of not using a cable outlet, it must be replaced with a certified blanking plug of an approved type.
5. Temperature on entry cables is max. 90°C .

Product protection

EA UL 0, UL 1, UL 2 does not have own short-circuit protection, therefore there must be included suitable protective device into the supply power (circuit breaker, or fuse), which serves at the same time as main switch. For protection, we recommend to use a fuse type "T" or a contactor type "C".

Type of equipment from a connection point of view: The equipment is designed for permanent connection.

1.7 Warranty conditions

The supplier is responsible for completeness of the delivery and guarantees these specifications of the product which are stated in the Contract.

The supplier is not responsible for any deterioration of parameters caused by the customer during storage, unauthorised installation or improper operation.

1.8 Under-guarantee and after-guarantee service

Our customers are provided with professional service of our firm in installation, operation, service, maintenance, revision and help in troubleshooting for all our products.

Under-guarantee service is performed by the service department of the production plant, or by a contracted service centre according to a written claim.

In case of occurring of any fault please let us know it and state:

- type code
- serial number
- ambient parameters (temperature, humidity...)
- duty cycle including frequency of switching
- type of switching-off (position or thrust)
- set switching-off thrust
- type of fault - description of claimed fault
- it is recommended to place also Installation certificate.

It is recommended to have **after-guarantee service** performed by the service department of the production plant, or by a contracted service centre, with national laws.

1.8.1 Lifetime of actuators

The lifetime of an electric actuator (EA) is at least 6 years.

EA used for closing mode (closing valves) comply with the requirements for at least **15,000 working cycles** (cycle C – O – C: for linear EA).

EA used for regulating/modulating operation (control valves) comply with the below stated numbers of **operating hours** at the total number of 1 million start-ups:

Switching frequency				
max. 1,200 [h ⁻¹]	1,000 [h ⁻¹]	500 [h ⁻¹]	250 [h ⁻¹]	125 [h ⁻¹]
Minimal lifetime expectancy – number of operating hours				
850	1,000	2,000	4,000	8,000

Time of **net operation** is min. 200 hours, max. 2,000 hours.

Lifetime at operating hours depends on loading and switching frequency.

Note : High switching frequency does not ensure better regulation. Setting of regulation parameters should be therefore made with the inevitably necessary switching frequency needed for the process in question.

1.9 Operation conditions

1.9.1 Product location and operation position

EA may be installed and operated in enclosed locations of industrial facilities with no temperature and moisture regulation, protected from direct climatic effects (such as direct sunlight). Moreover, special “marine” versions may be used in waste water treatment applications, water management, selected chemical applications, tropical environments and coastal areas.

Warning:



Actuator installed on the open place must be protected against a direct climate effects by shelter.

Installation and operation of EA is possible in **any position**. Vertical position of output part axis and with the control part above the valve is usual.

1.9.2 Working environment

According to valid standard IEC 60 721-2-1, there are delivered these versions of electric actuators:

- 1) Version „standard“ for type climate temperate
- 2) Version „tropical wet“ for type climate tropical wet
- 3) Version „cold“ - for type climate cold
- 4) Version „tropical dry and dry“ for type climate tropical dry and dry
- 5) Version „marine“ for type climate marine
- 6) Version „arctic“ for type climate arctic.

In accordance with IEC 60 364-1, IEC 60 364-5-51 within valid edition the EA have to resist external effects and operate reliably:

In the conditions of the following types of environment:

- warm mild to very hot dry with temperature in range -25°C to +55°CAA 7*
- cold to warm mild and dry with temperatures in range -50°C to +40°CAA 8*
- cold to mild hot dry with temperatures in range -60°C až +40°C AA 1*+AA 5*
- with relative humidity 10 to 100 %, including the condensation of up to 0,029 kg water content per 1 kg of dry air, at above stated temperatureAB 7*
- with relative humidity of 15÷100%, including the condensation of up to 0,036 kg water content per 1 kg of dry air, at above stated temperatureAB 8*
- with relative humidity 5 to 100 %, including the condensation of up to 0,025 kg water content per 1 kg of dry, at above stated temperature AB 1*+AB 5*
- with elevation up to 2000 m, with barometric pressure range from 86 kPa up to 108 kPa AC 1*
- with exposure to intensive water jets (IPx6) AD 6*
- with submersion – (product with enclosure IPx8)..... AD 8*
- with strong dustiness – with a possibility of influences of inflammable, non-conducted and non-explosive dust; the middle layer of dust; the dust drop more than 350 but not more than 1000 mg/m² per day (products with protection enclosure of IP 6x).....AE 6*
- expose to corroding or pollute chemical substances during producing or using of these substances); at places where is handled with small quantity of chemical products and these can accidentally get in contact with an electric deviceAF 3*
- with permanent exposure of big amount of corroding or contaminated chemical and salt fog in execution for sea environment, fog sewage water disposal plant and some chemical plantAF 4*
- with a possibility of influences of mechanical stress:
 - medium impacts, shocks and vibrations AG 2*
 - medium sinusoid vibrations with frequency in range 10 up to 150 Hz, with shift amplitude of 0,075 mm for $f < f_p$ and acceleration amplitude 9,8 m/s² for $f > f_p$; (transition frequency f_p is from 57 up to 62 Hz) (applies to 2 pillars version)..... AH 2*
 - medium sinusoid vibrations with frequency in range 10 up to 150 Hz, with shift amplitude of 0,15 mm for $f < f_p$ and acceleration amplitude 19,6 m/s² for $f > f_p$; (transition frequency f_p is from 57 up to 62 Hz) (applies to 4 pillars version)..... AH 2*
- with serious danger of plants and mould growingAK 2*
- with serious danger of animal occurrence (insects, birds, small animals) AL 2*
- with detrimental influence of radiation:
 - of stray current with intensity of magnetic field (direct or alternate, of mains frequency) up to 400A.m⁻¹AM2*
 - of sun radiation with intensity > 500 and ≤ 700 W/m² AN 2*
- with effects of medium seismic activity with acceleration > 300 Gal ≤ 600 GalAP 3*
- with indirect endanger by storm..... AQ 2*
- with quick air movement and strong wind AR 3 , AS 3*
- stand on a conductive bottom) BC 3*
- without any danger media with object BE 1*

* Marking in accordance with IEC 60364-1, IEC 60 364-5-51 and IEC 60 364-5-55 within valid edition

1.9.3 Power supply and duty cycle

Power supply:

electric motor..... 24 V AC/DC; 120 V AC, 230 resp. 220 V AC; 3x400 resp. 3x380 resp. 3x415 V AC resp. 3x460 V AC $\pm 10\%$, according to valid certificates

control..... 24 V AC resp. 220-240 V AC $\pm 10\%$

Power supply frequency.....50 Hz, or 60**Hz $\pm 2\%$

** Note: At frequency of 60 Hz operating speed is reduced by 1.2 times.

Duty cycle - according to EN/IEC 60034-1 within valid edition:

EA UL 0, UL 1, UL 2 are designed for **remote control**:

- short-time operation S2-10 min
- intermitted operation S4-25%, max. 90 cycles per hour

EA with controller are designed for **automatic regulation**:

- intermitted operation S4-25%, 90 up to 1200 cycles per hour

Notes:

1. *Duty cycle consist of load type, load factor and switching rate.*
2. *Once EA is connected to the external controller unit, also use it as a control EA where the max. load thrust reaches the 0.7 multiple of the maximum loading thrust for remote operated EA UL 0, UL 1, UL 2.*

1.10 Packing, transport, storing and unpacking

Surfaces without surface treatment are treated by conservation preparation MOGUL LV 2-3 before packaging .

Conservation is not necessary if the following storage conditions are complied with:

- Storage temperature: -10 to +50 °C
- Relative air humidity max.80 %
- Electric actuators and their accessories must be stored in dry, well ventilated covered spaces, protected against impurities, dust, soil humidity (by placement to racks, or on palletes), chemicals and foreign interventions
- There shall be no corrosive gases present in the storage areas.

The of **UL 0, UL 1 UL 2** are delivered in solid packages guaranteeing resistance in accordance with EN/IEC 60 654.

Package is a box. Products in boxes is possible to load on the pallets (pallet is returnable). On the outer side of the package is stated:

- manufacturer label,
- name and type of product,
- number of pieces,
- other data – notices and stickers.

The forwarder is obliged to secure packed products, loaded on transportation means, against self-motion; if open transportation means are used, to secure their protection against atmospheric precipitations and splashing water. Displacement and securing of products in transportation means must provide their stable position, exclude the possibility of their inter-collision and their collision with the vehicle walls.

Transportation can be executed by heatless and non hermetic spaces of transportation vehicles with influences within the range:

- temperature: -25° C up to +70°C (a strange version –45 ° C up to +45 ° C)
- humidity: 5 up to 100 %, with max. water content 0.028 kg/kg of dry air
- barometric pressure 86 up to 108 kPa

After receiving EA check whether during transport or storage the actuator was not damaged. Compare also whether the parameters on their nameplates are in accordance with accompanying documentation or the Contract. If any discrepancy or fault occur inform immediately your supplier.

If the actuators and accessories are not immediately installed, they have to be stored in dry, well-ventilated sheltered rooms, protected against dirt, dust, soil humidity (with placing onto shelves or onto pallets), chemical impacts and encroachment, at ambient temperature from -10°C up to +50 °C and relative humidity max. 80 %, in special version at temperature –70°C do +40°C.

- It is forbidden to store EA outside or in areas not prevented against direct impact of climate.
- Strains of the surface finishing should be promptly removed if any – it can prevent the product against corrosion damages.
- While storing more than one year it is necessary to check lubrication filling before the actuator is put into operation.
- The EA installed but not operated are to be protected the same way as when storing (e.g. with a wrapping).
- After it is mounted onto a valve in free and wet areas or in areas where temperature is changing it is necessary to connect the space heater – to prevent the actuator against corrosion resulted from water condensed in the control part.
- Remove odd conservation grease as late as before putting into operation.

1.11 Assessment of the product and packaging and removal of contamination

The product and its package are made of recycling materials. Do not throw the single parts of the package and of the product after their life but sort them according to instructions in corresponding executives or regulations of environment protection, and allow their recycling.

The product and its packing are not a source of any environment pollution or contamination and do not contain any dangerous waste.

2. Description, function and specifications

2.1 Description and function

EA UL 0-Ex, UL 1-Ex, UL 2-Ex are of compact construction. They are composed of two functionally different main parts:

The **gear part** is made up by a flange with a connecting part, resp. linear mechanism for connection onto a controlled device, and gears placed in the bottom; on the other side drive mechanisms for control part units are surfaced.

The **control part (Fig. 1, 1a, 1b)** is placed on a control board (1) consisting of:

- electric motor (2) (at single-phase version with capacitor)
- thrust unit (5) - controlled with a worm axial shift
- position-signalling unit (3) with a position transmitter (6)- positioner (resistive - potentiometer, capacitive or electronic position transmitter)(7) and with a mechanical local position indicator (4)
- space heater with thermal switch (8)
- electronic module (9)
- electrical connection through terminals (10), located in the control area and cable glands Ex d version

Additional accessories:

Manual control: made up by a handwheel with a worm gearing.

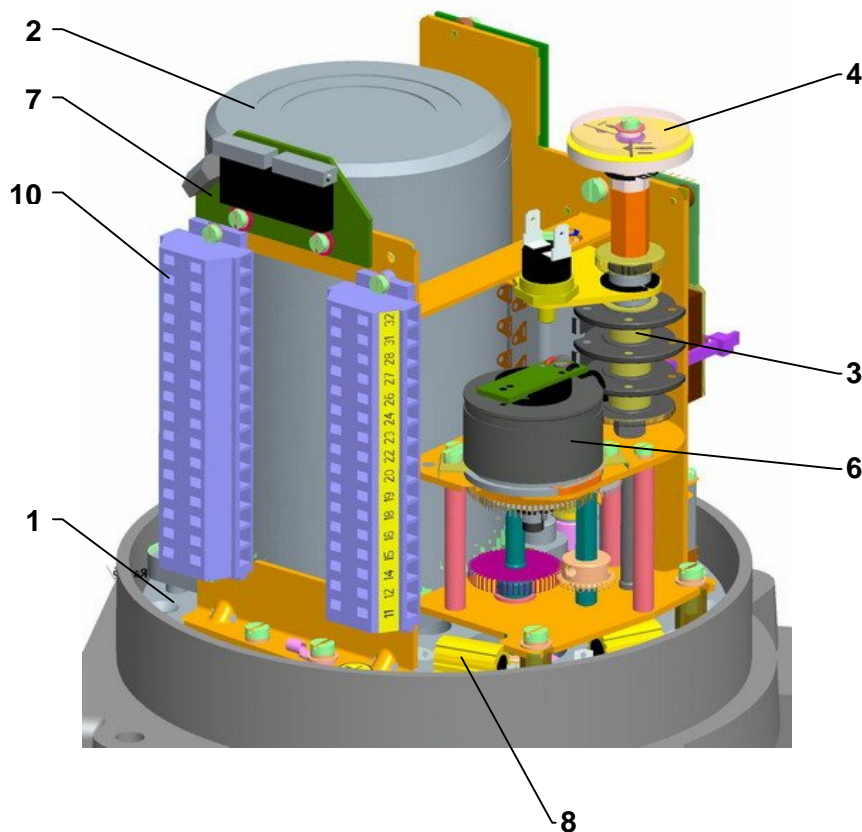

Fig.1

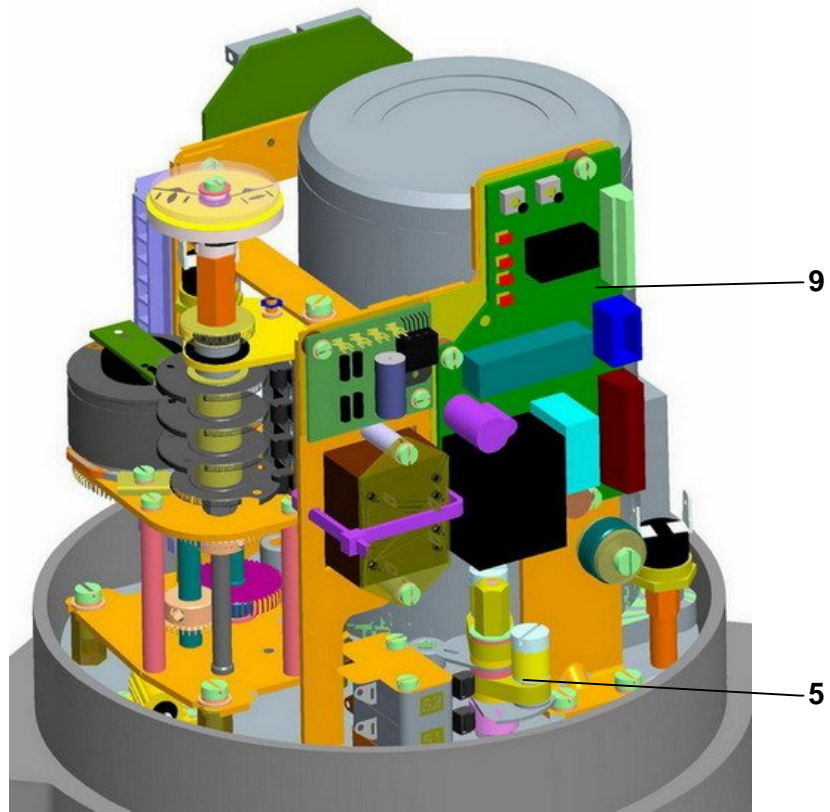

Fig.1a



Fig.1b

2.2 Basic specifications

Basic EA specifications: are given in Table 1.

Table 1: Basic EA specifications

Type number	Operating speed ±10[%] ²⁾	Operating stroke	Max. load thrust	Switching-off thrust ±10 [%]	Weight	Electric motor ¹⁾						
						Power supply nominal voltage	Nominal		current		Capacitor capacity	
							power	speed	nominal	starting ±20 %		
	[mm/min]	[mm]	[kN]	[kN]	[kg]	[V]	[W]	[1/min]	[A]	[µF/V AC]		
	50Hz 60Hz											
UL 0 type number 540	10	4 - 40 Without transmitter	6,0	6,9	6,5 - 8	Single-phase	230 (220) resp. 24	13,8	375	0,135 resp. 1,35	0,13 resp. 1,43	0,82/500 resp. 82/63
	15											
	20											
	40											
	80		6,0	6,9			110	13,8 14,2	375/450	0,27 0,3	3,3/250	
	10 12											
	15 18											
	20 24											
	40 48											
	80 96											
UL 1 type number 541	10	4 - 80 Without transmitter	10	7,5-12,5	16 - 19	Single-phase	230 (220)	40	1300 (1250)	0,53	1	5/400
	20											
	40											
	80											
	10 12		10	7,5-12,5			120 (110) 60Hz	40	1500	0,67 1,27	9,0	
	20 24											
	40 48											
	80 96											
	10		10	7,5-12,5			24 AC/DC	53	2600	3,1	-	-
	20											
	40											
	80											
	10		10	7,5-12,5			3x400 (3x380) resp. 3x415	40	1300	0,21	0,4	-
	20											
	40											
	80											

Type number	Operating speed ±10[%] ²⁾	Operating stroke	Max. load thrust	Switching-off thrust ±10 [%]	Weight	Electric motor ¹⁾										
						Power supply nominal voltage	Nominal				Capacitor capacity.					
							power	speed	current							
		nominal	starting ±20 %													
	[mm/min]	[mm]	[kN]	[kN]	[kg]	[V]	[W]	[1/min]	[A]	[μF/V AC]						
	50Hz 60Hz															
UL 2 type number 542	14	4- 100 Without transmitter	21,5	15-25	26 až 34,2	Single-phase	230 (220)	60	2750	0,7	1,35	7/400				
	25							120	2600	1,0	1,9	8/450				
	40								120 60Hz	3380	1,1	2	16/250			
	60									120	3100	2,0	3,8	8/450		
	80										24 AC/DC	100	3350	4,9	-	-
	100											Three-phase	3x400 (3x380) resp. 3x415	90	2740	0,35
	120		180	2650			0,6	2,4	-							
	14									21,5 resp. 14	15-25 resp. 10-16					
	25												21,5 resp. 14	15-25 resp. 10-16		
	40															
	60															
	80															
	100															
	120															

1) Switching elements for different type of load (also for EA) defines standard EN/IEC 60 947-4-1.

2) Anomaly of operating speed ±10% at 230 V resp. 220 V AC, 3x400 resp. 3x380V resp. 3x415 V AC.

Additional technical data:

EA protection enclosure: IP 66/IP 68 (EN/IEC 60 529 within valid edition)

According to definition for EA, enclosure IP68 fulfills following requirements:

-water column max. 10m

-time of continuous submersion in water max. 96 hours.

Mechanical ruggedness:

sinusoidal vibrations: with frequency in range 10 to 150 Hz,
with shift amplitude of 0,15 mm for $f < f_p$,
with acceleration amplitude of $19,6 \text{ m/s}^2$ for $f > f_p$,
(transition frequency $f_p = 57$ to 62 Hz)

drop resistance:300 drops with acceleration 2 m.s^{-2}

seismic resistance:amplitude of the shock off 6 on Richter scale

Self-locking: the EA is self-locked

Electric motor protection: with thermal switch, except UL 0

EA braking: by roller bief

Output part backlash: max. 0,5 mm at load of 5%-of maximum thrust

Electric control:

- remote control (the output element of the EA is controlled with supply voltage), resp. by feeding of unified signal

Adjustment of the limit positions:

The limit position switches are set to operating stroke with accuracy of $\pm 3\%$ of the stroke specified in the EA nameplate.

Additional position relays (S5,S6) are adjustmentcca 0,5 mm beneath the limit switches

Hysteresis of position switches max. 2,5% from stroke on nameplate

Adjustment of the thrust switches:

Switching – off thrust in case EA UL 0-Ex cannot be adjusted at customer!

Switches (S1,S2,S3,S4,S5,S6)**UL 0:**

Type **DB 6** - equipped with the silver contacts – standard version

250 V AC; 20mA - 2 A; $\cos \varphi = 0.6$;

24 V and 48 V DC; 20mA -1A; $T=L/R=3\text{ms}$;

min. voltage : 20 V

insulation resistance: 50 M Ω

Type **DB 3**- gold-plated contacts (valid for switches S5, S6, resp. after agreement for switches S3, S4, too)

max. 250 V AC; 1mA - 0,1 (0,05)A;

24 V and 48 V DC, 1mA - 0,1 A ; $T=L/R=3\text{ms}$

UL 1, UL 2:

Type **D 38: silver contacts** – standard version

- voltage 250 V(AC); 50/60 Hz; 16(4) A; $\cos \varphi=0,6$ resp.: 24 V(DC); $T=L/R=3\text{ms}$; min. current 100mA

Type **D 41:gold-plated contacts (is not valid for switches S1, S2 in the version with reverse contactors)**

- voltage 0,1 (0,05) A, max. 250 VAC; 0,1 / 24 VDC; $T=L/R=3\text{ms}$; min. current 5mA

Relay thrust of switch S1, resp. S2 (ReS11, ReS12):

Model RT 424

- 250 V AC, 8 A; 24 VDC, 8 A; max. switching-on power AC 2000 VA

Space heaters (E1)

The space heater – supply voltage:.....according to the supply voltage of the motor (24,max. 250 V AC);

UL 0:

Heating power: cca 10 W/55°C

Switching resistor..... with thermal switch

UL 1:

Heating power for range temperature from -50 °C: cca 20 W/55 °C

Switching resistor with thermal switch

UL 2:

Heating power for range temperature from -50 °C: cca 40 W/55 °C

Switching resistor with thermal switch

Thermal switch of space heater (F2)

Supply voltage: corresponding with motor supply voltage (max. 250V AC, 5 A)
 Switching-off temperature:..... +30°C ± 4K
 Switching-on temperature:..... +20°C ± 3K

Manual control:

By handwheel after unscrewing the locking screw (except UL 0). Rotate the handwheel clockwise to move the output shaft in the direction „Z“.

Position transmitters**Resistive position transmitter**

Resistance (single **B1**) 100; 2 000 Ω
 (double **B2**) 2x100 Ω, 2x2000 Ω
 Operating life of transmitter 1.10⁶ cycles
 Load capacity 0,5 W do 40 °C, (0 W/125°C)
 Maximum current of sliding contact max.35 mA
 Maximum supply voltage..... $\sqrt{P \times R}$ V DC/AC
 Potentiometer linearity error ±2,5 [%]¹⁾
 Potentiometer hysteresis max. 2,5 [%]¹⁾
 Potentiometer values at limit positions: “O“ (open)..... ≥ 93%, ”Z“ (closed)..... ≤ 5%

Capacitive (B3): non-contact, life 10⁸ cycles

2-wire connection with built-in power supply or without built-in power supply

The current signal **4 ÷ 20 mA** (DC) is acquired from the capacitive transmitter supplied from the internal or an external voltage supply source. The electronics of the transmitter is protected against eventual wrong polarity and current overloading. The entire transmitter is galvanic insulated so several transmitters can be connected to one external voltage source.

Power supply voltage (with power supply) 24 V DC
 Power supply voltage (without power supply) 18 to 28 V DC
 Ripple voltage max. 5%
 Max power input 0,6 W
 Load resistance 0 to 500 Ω
 Load resistance can be single side grounded.
 Influence of resistance on output current 0,02%/100 Ω
 Influence of voltage on output current 0,02%/1V
 Temperature dependency 0.5% / 10 °C
 Output signal values at limit positions:
 “O“ 20 mA (terminals 81; 82)
 “Z“ 4 mA ((terminals 81; 82)
 Values tolerance of output signal of EPV
 “Z“ +0,2 mA
 “O“ ±0,1 mA

DCPT2 – current transmitter (B3)

- 2-wire connection without built-in power supply or with built-in power supply

Current signal 4 ÷ 20 mA (DC) with optional mirroring (20 ÷ 4 mA)
 Mode of operation contactless, magnetic resistance
 Transmitter increments without gears 0.352 °
 Loading resistor: 0 through 500 Ω
 Operating stroke 35 to 100% of the rated stroke at the gear ratio
 Non-linearity max. ±1 %
 Non-linearity - geared max. ±2.5 %
 Power supply voltage for version without power source 15 through 28 V DC, max.42 mA
 Power supply voltage for version with built-in power source 24 V DC
 Operating temperature -25 to +70°C
 Linearity deviation: ±2.5 %¹⁾
 Hysteresis max. 2.5 %¹⁾
 Error messages by flashing LED

1) from rated value of transmitter referred to output values

Electronic positional transmitter (EPV) - converter R/I (B3)**2-wire version, resp. 3-wire (without built-in power supply, or with built-in power supply)**Output signal for 2-wire version $4 \div 20$ mA (DC)Output signal for 3-wire version $0 \div 5$ mA (DC) $0 \div 20$ mA (DC) $4 \div 20$ mA (DC) $0 \div 10$ V (DC) – only for UL 0Power supply voltage for **2-wire version without built-in power supply**..... 15 to 30 V DCPower supply voltage for **2-wire version with built-in power supply** 24 V DC $\pm 1,5\%$ Load resistance for **2-wire version**max. $RL=(U_n-9V)/0,02A$ [Ω]..... (U_n – voltage [V])Power supply voltage for **3-wire version** 24 V DC $\pm 20\%$ (pre UL 0), $\pm 1,5\%$ (for UL1,2)Load resistance for 3-wire version for UL1, UL 2max. 3 k Ω Load resistance for 3-wire version 0 - 5mA for UL 0max. 3 k Ω Load resistance for 3-wire version 0 - 20mA for UL 0max. 750 Ω Load resistance for 3-wire version 0 - 10 V for UL 0min. 10 k Ω

Temperature dependency..... max. 0,020 mA / 10 C

Output signal values at limit positions on the terminal 81,82 „O“..... 20 mA (5 mA, 10 V)

..... „Z“..... 0 mA (4 mA, 0 V)

Values tolerance of output signal „Z“ $\pm 1,5\%$ ¹⁾..... „O“ $\pm 1,5\%$ ¹⁾Linearity deviation..... $\pm 2,5\%$ ¹⁾Hysteresis max. 2,5 %¹⁾*1) from rated value of transmitter referred to output values***Lubricators :**

- see chapter Maintenance - extent and periodicity

2.2.1 Mechanical connection

- flange or pillars

Basic and connecting dimensions are given in dimensional drawings.

2.2.2 Electrical connection

Terminals (X) for EA UL 0 - max. 24 screw-less terminals

with connecting wire cross-section of 0.08 to 1.5 mm²

Terminals (X) for EA UL 1, UL 2 - max. 32 screw-less terminals

with connecting wire cross-section of 0.08 to 2.5 mm² ;

Cables input - as standard (temperature on entry of cables is max. 90°C):

UL 0:1 cable gland - 1xM16x1,5 ($\varnothing D = 3,2$ to 7,0 mm);1 cable gland - 1xM16x1,5 ($\varnothing D = 5,0$ to 10,0 mm);1 cable gland - 1xM16x1,5 ($\varnothing D = 5,0$ to 10,0 mm);**UL 1, UL 2:**1 cable gland - M20x1,5 ($\varnothing D = 3,2$ to 8,7 mm);1 cable gland - M20x1,5 ($\varnothing D = 6,1$ to 11,7 mm);1 cable gland - M20x1,5 ($\varnothing D = 6,5$ to 14,0 mm);

1) Encapsulation of cable:

For cable glands fixing there is used glue WEICONLOCK AN 302-43.

The cable used must be in accordance with STN EN 60079-14, chapter 10.6.2.

Attention: Thermic resistance incoming wires must be minimum +90°C.

Table 3: Wire cross-section conversion table (mm² – AWG)

Wire cross-section conversion table (mm ² – AWG)	
Wire cross-section	
mm ²	AWG
0,05	30
0,2	24
0,34	22
0,5	20
0,75	18
1,5	16
2,5	14
Tightening torque conversion table (N.m – lbs.-in)	
Tightening torque	
N.m	lbs.-in
0,2	2,7
0,3	4
0,5	7

Protective terminal:

Upon start-up in operation - at equipment installation:

- for safe use of the actuator it is necessary to connect the outside and inside grounding terminal. The position of the outside and inside grounding terminal can be seen in Fig. 1c and Fig. 1d. HP3 insulated eyelet crimping pliers should be used to crimp wire to the outside grounding terminal (by CAMBER). Outside and inside earth terminal are mutually interconnected and identified with a protective grounding symbol.

There must be power switch or motor circuit breaker included to the power supply which must be placed as close as possible to the device, easily accessible to the operator and marked as an disconnecting device of actuator. The electrical connection is made according to the wiring diagrams inserted or glued to the top cover of the EA.

Product protection

To protect the product, we recommend using fuses or a suitable circuit breaker.

Table 4: Fuse values and characteristics

Type	Order code	Voltage	Frequency (Hz)	Electric motor Power / Power input (W)	max. current EA (A)	Fuse values F3
UL 0 540	540.X-0XXXX/YY	230 VAC	50	13,8/31	0,22	T 0,500 A / 250 V
	540.X-LXXXX/YY	220 VAC				
	540.X-3XXXX/YY	24 VAC	50/60		2,2	T 3,15 A / 250 V
UL 1 541	541.X-0XXXX/YY	230 VAC	50	40/90	0,5	T 1,6 A / 250 V
	541.X-LXXXX/YY	220 VAC				
	541.X-1XXXX/YY	3x400 VAC 3x415 VAC	50	40/110	0,3	T 0,8 A / 250 V
	541.X-MXXXX/YY	3x380 VAC				
UL 2 542	542.X-0XXXX/YY	230 VAC	50	60/120	0,86	T 1,6 A / 250 V
	542.X-LXXXX/YY	220 VAC				
	542.X-1XXXX/YY	3x400 VAC	50	90/150	0,56	T 1,0 A / 250 V
	542.X-2XXXX/YY	3x415 VAC				
	542.X-MXXXX/YY	3x380 VAC				
	542.X-NXXXX/YY	3x380 VAC	50	120/228	1,3	T 1,6 A / 250 V
	542.X-0XXXX/YY	230 VAC				
	542.X-LXXXX/YY	220 VAC	50	180/300	0,82	T 1,6 A / 250 V
	542.X-1XXXX/YY	3x400 VAC				
	542.X-2XXXX/YY	3x415 VAC				
	542.X-MXXXX/YY	3x380 VAC				
542.X-NXXXX/YY	3x380 VAC					

Electric connection: - according to the wiring diagram stuck into the case of the EA.

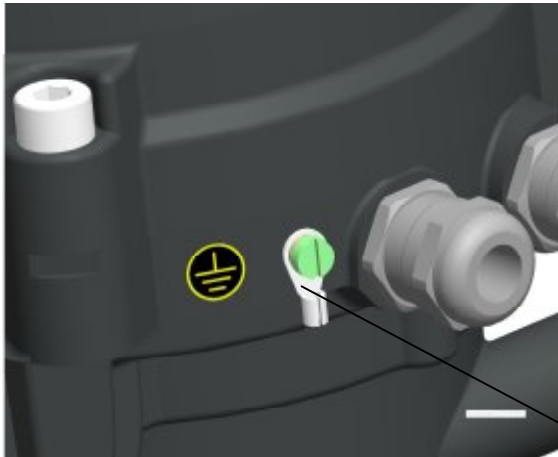

OUTSIDE
GROUNDING
TERMINAL

Fig.1c

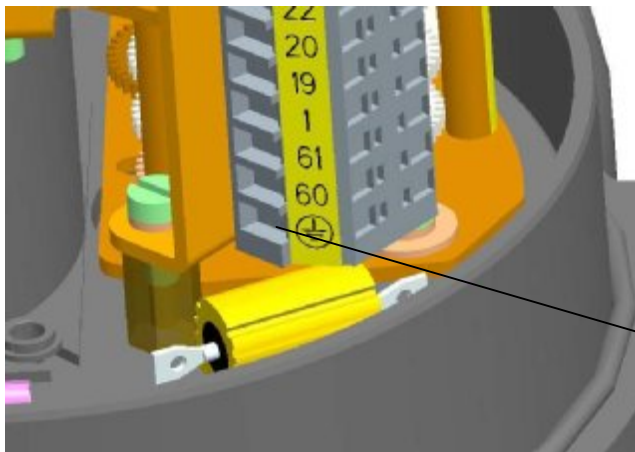

INSIDE
GROUNDING
TERMINAL

Fig.1d

3. Installation and dismantling of actuator



Abide by safety measures!

Note:

Check again if placement of EA reply to chapter "Operation conditions". In case that operation conditions are different from recommended, consultation with producer is needed.

Before starting of mounting the EA onto the valve:

- Check again whether the EA was not damaged during storing.
- Check whether the adjusted operation stroke and connecting dimensions of the actuator (see the nameplate) are in compliance with the valve parameters.
- In case of inconsonance, perform adjusting according to the part "Adjustment".

3.1 Installation

EA is by the producer adjusted to parameters according to the nameplate.
Before installation put the handwheel on.

3.1.1 Mechanical connection flange connection

- Defat the abutting areas of the connecting flange of the EA valve or the gear carefully;
- Lubricate the output shaft of the valve/gear with a grease not containing any acids;
- Set the EA to the limit position "closed", set the valve to the same position;
- Put the EA onto the valve with the output shaft reliably stalled in the valve coupling/gear;
- **Attention! Do not adjust EA on an armature forcibly because of damage of the gear!**
- Use the handwheel to turn the EA to fit the openings in the EA and valve flanges if needed;
- Check whether the connecting flange abuts with the valve/gear.
- Fix the flange with four screws (with mechanical strength min 8G) fixed the way the actuator can Be moved. Tighten the screws equally in cross.
- At the end check the correctness of the fixture with the valve with rotating the handwheel.

3.1.2 Cable routing and connection

Temperature on entry cables is max. 90°C.

3.1.3 Electric connection and checking of function

Follow up with connecting the EA with mains or master system.



1. Follow instructions in the part "Requirements for professional qualification"!
2. While laying electrical line abide by the instructions for heavy current installations. Power supply cables must be of the type approved. Minimum thermal resistance of power supply cables and wires must be +90°C.
3. Cables to terminal boards or connectors lead through screw cable glands.
4. Before initiation EA into operation internal and external protection terminals are needed to be connected.
5. Feeding cables are to be fixed to the solid construction at most 150 mm from the cable glands.
6. Thrust switching is not fitted with mechanical interlocking device (except for UL 2)

Connection with the terminal board:

Before the connection remove the actuator case and check whether the type of current, power supply and frequency correspond with the data on the actuator nameplate.

Electric connection:

- The electric connection should be realized according to the wiring diagram stuck into the case of the EA;
- The electric connection should be performed through two cable glands see No. 2.2.2.
- Once electrical services are completed put on the cover and fasten it evenly crosswise by bolts. Fasten the cable glands to ensure specified shielding.

Notes:

1. To connect the input control signals and output signals is needed to use shielded wires with steel wire braid (Galvanised Steel Wire Braid GSWB Ξ), for example cable type "Bruflex $\text{\textcircled{R}}$ HSLCH", 4x0, 5 (company Bruns Kabel).
2. The EA are delivered with cable glands which in case of correct tighten are onto the supply lead allow the protection enclosure of IP 68.
3. The cable is to be fixed the way corresponding with its allowable bending radius not to damage or deform the sealing element of the cable lead. The supply leads have to be fixed onto a fixed construction max. 150 mm from the leads.
4. It is recommended to connect the remote transmitters with shielded wires.
5. The face areas of the control part cover should be clean before fixing it back.
6. The EA is reversible if the time interval between the power supply is switched off and on for the reverse direction of the output part motion is at least 50 ms.
7. The allowed delay after it is switched off, i.e. time from the switches reaction up to the motor without any voltage is 20 ms maximally.



Observe the valve manufacturer's instructions with respect to the requirement to ensure switching-off in limit positions through position or thrust switches!

Caution:



1. Power supply to the actuator and connections with switching, protective and safety devices may be carried out only by personnel with appropriate qualification, in compliance with the corresponding standards and wiring diagrams, such as those specified in the Instruction Manual...
2. All terminal connections must be checked after connection of the power supply cables. The conductors must not apply any bending or tensile stress upon the connecting terminals. The following measures should be taken when using aluminum conductors:
3. Immediately before connecting the aluminum conductor, it is necessary to remove the oxide layer on the surface and prevent the oxidation by application of neutral vaseline to protect the connection.

After connection, check the correct direction of the actuator shaft rotation by short activation of the actuator in intermediate position. This can also be checked by using a stick made of insulating material to activate the corresponding micro-switch - limit, position or thrust (depending on the type of actuator control) during operation of the actuator.

If the actuator does not stop, but stops upon signal from micro-switch corresponding to the opposite rotation direction, you will need to change the direction of rotation of the actuator output shaft. In case of an actuator driven by single-phase electric motor, the direction of rotation can be changed by switching the supply cables on the terminals of the electric motor.

In case of actuators with three-phase electric-motor, interconnect one of the pairs of conductors on terminals U, V, W of the actuator terminal board. Repeat the function test again.

Important!

- 1) During adjustment, repair and maintenance, secure the actuator by prescribed means in order to prevent its power-up resulting in the possibility of electric shock injury or injury by rotating parts.
- 2) When reversing the operation of actuators with single-phase electric motor, power supply must never be connected simultaneously to both outputs of the start-up capacitor at the same time, otherwise the capacitor could discharge through thrust switch contacts resulting in their sticking together.

After adjustment of the actuator, check its operation using the control circuit. Especially make sure that the actuator starts-up correctly and that the electric motor is disconnected from power supply after triggering of the corresponding micro switch. Otherwise immediately disconnect the power supply to the actuator to prevent damage to the electric motor and try to locate the malfunction.

After the EA is electrically connected it is advised **to check functions:**

- After the EA is electrically connected to check the correct functions of the position and the thrust switches S1 - S6 and if needed adapt the order of the single phase leads for the 3-phase electric motor.
- Set the valve manually into mid-position.
- Connect the power supply to the terminal for supplying the EA in the direction "opening" and follow the direction of the output shaft of the actuator rotation. When EA is connected correctly, the output shaft of EA, into the actuator control part from the top, must rotate counterclockwise. If not, it is necessary to change the phase leads L1 and L3 on the terminals 2 and 4 mutually, valid for 3-phase electric motor. After the exchange is made check the direction of the EA rotation.

- If any of the functions is not correct, check the switches whether they are wired properly according to the wiring diagrams.

3.2 Dismantling



**Before dismantling it is required to disconnect the EA from mains!
Do not connect and disconnect live connectors!**

- Disconnect the EA from mains.
- Disconnect the leads from the EA terminal boards and loosen the cables from cable glands. Pull out the connectors in case of the connector version.
- Loosen the fixing screws of the EA flange and coupling screws and disconnect the EA from the valve.
- While sending the EA to be repaired put it into a package solid enough to avoid damages of the EA during transportation.

4. Adjustment



Keep safety regulations! Follow the prescribed procedure to assure that the EA is not connected to mains when live not to cause any injury by electrical current!

The adjustment is performed with the EA mechanically and electrically connected and the connection and functions were checked. The chapter describes the adjustment of the EA to the parameters given in the nameplate in case that any of its parts is out of tune. The adjusting parts on Fig.1.

Definition of the direction of movement:

- movement direction "**close**" - the output shaft of the actuator rotates in the clockwise direction when looking into the actuator control part from the top.
-

4.1 Adjustment of the Thrust Unit

The switching - off thrust are adjusted by the producer for both directions, i.e. for the direction "opening" (the thrust switch S1) as well as for the direction "closing" (the thrust switch S2) to the specified value with tolerance of $\pm 10\%$. If not stated else they are adjusted to the maximum rate. It is impossible to align and adjust the thrust unit for EA **UL 0** actuator to alternative values of thrust without test equipment to measure thrust.

Adjustment and setting of the thrust unit for EA UL 1 actuator to alternative thrust values is possible through the use of adjustment screws according to Fig. 2. Switching-off thrust can be reduced by rotating the graduated screws along the gauge mark on the arm of the thrust unit. Adjustment to longest mark results in resetting the switching-off thrust to maximum value. Adjustment to the shortest mark results in the reduction of the switching-off thrust.

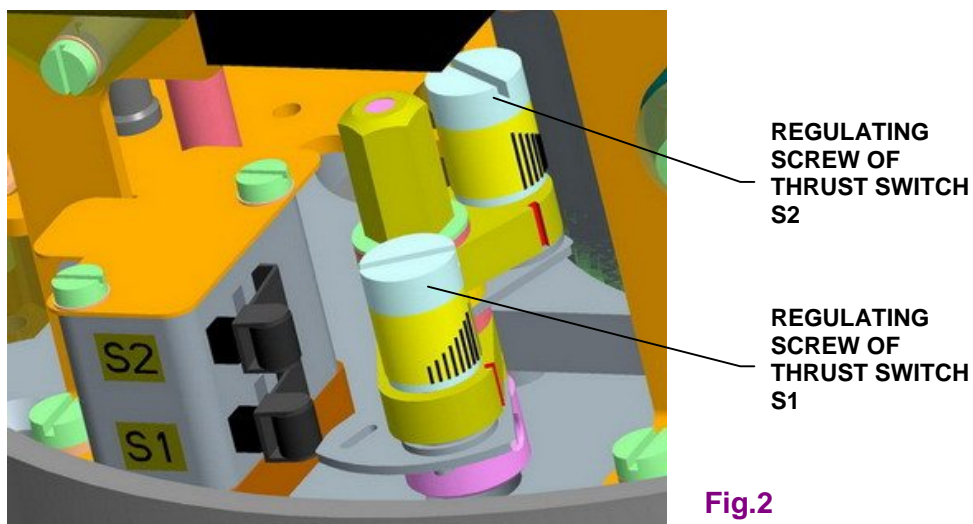

Fig.2

Adjustment and setting of the thrust unit for EA UL 2 actuator to alternative thrust values is possible through the use of adjustment segments according to Fig. 2a. Thrust can be reduced by releasing the screw and sliding the graduated segment along the gauge mark on the arm of the thrust unit. Adjustment towards M results in resetting the switching-off thrust to maximum value. Adjustment towards 0 results in reduction of the switching-off thrust.

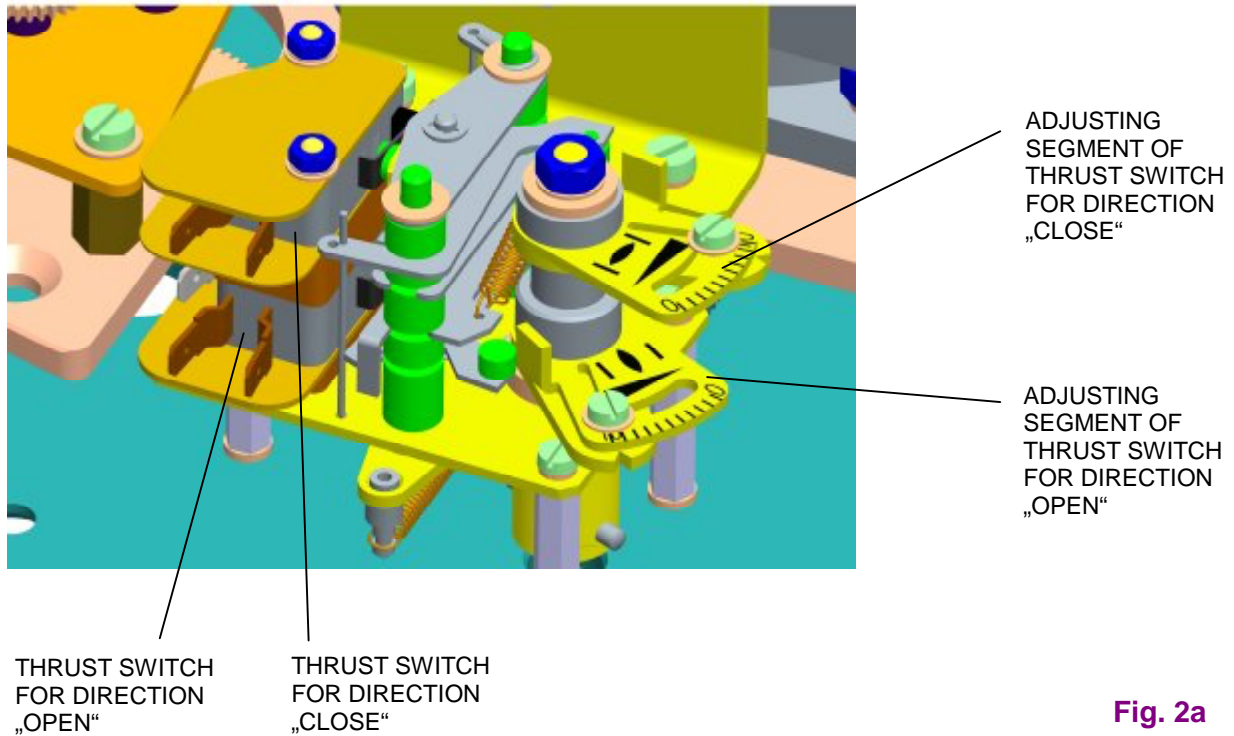

Fig. 2a

4.2 Adjustment of position-signalling unit

UL 1, UL 2 (Fig.3):

The EA are in the production plant adjusted to a fixed stroke (according to the specification), given on the nameplate. While setting, adjusting and resetting follow these steps (Fig. 3):

- Move the sliding gear about requested degree of the range according to the Table No. 5a and Fig. 3c by loosening the screw of the adjustable gear and tighten it after being set in the correct position. While adjusting the adjustable gear be careful that it meshes correctly with the gear of the given degree.
- in the version with a resistant transmitter (Fig.4) disengage the transmitter;
- loosen the nut (22) with simultaneous holding the central milled nut (23) and then loosen the nut (23) fixing the cams still having the belleville springs which create axial thrust;
- reset the EA to the "Open" position and rotate the cam (29) clockwise (when viewing the actuating plate from above) until switch S3 switches over (25);
- reset the EA by the angle where the "Open" position is to be indicated and turn the cam (31) clock-wise until switch S3 switches over (27);
- reset the EA to the "Closed" position and turn the cam (28) counter clockwise until switch S4 switches over (24);
- reset the EA back by the angle where the "Closed" position is to be indicated and turn the cam (30) counter clockwise until switch S6 switches over (26);
- once the EA is adjusted manually tighten the central milled nut (23) to lock the cams and tighten the lock nut (22) while simultaneous holding the milled nut;
- swing the position indicator discs (32) for the given operating stroke against the gauge mark on the top cover sight;
- once of the position- signalling unit is adjusted also adjust the position transmitter, converter or controller.

Note 1: Signalization possibility is available during the whole operating stroke in both directions, i.e. 100%.

- Note 2: - Marking switches
S3 - position switch "Open"
S4 - position switch "Close"
S5 - additional position (signalling) switch "Open"
S6 - additional position (signalling) switch "Close"

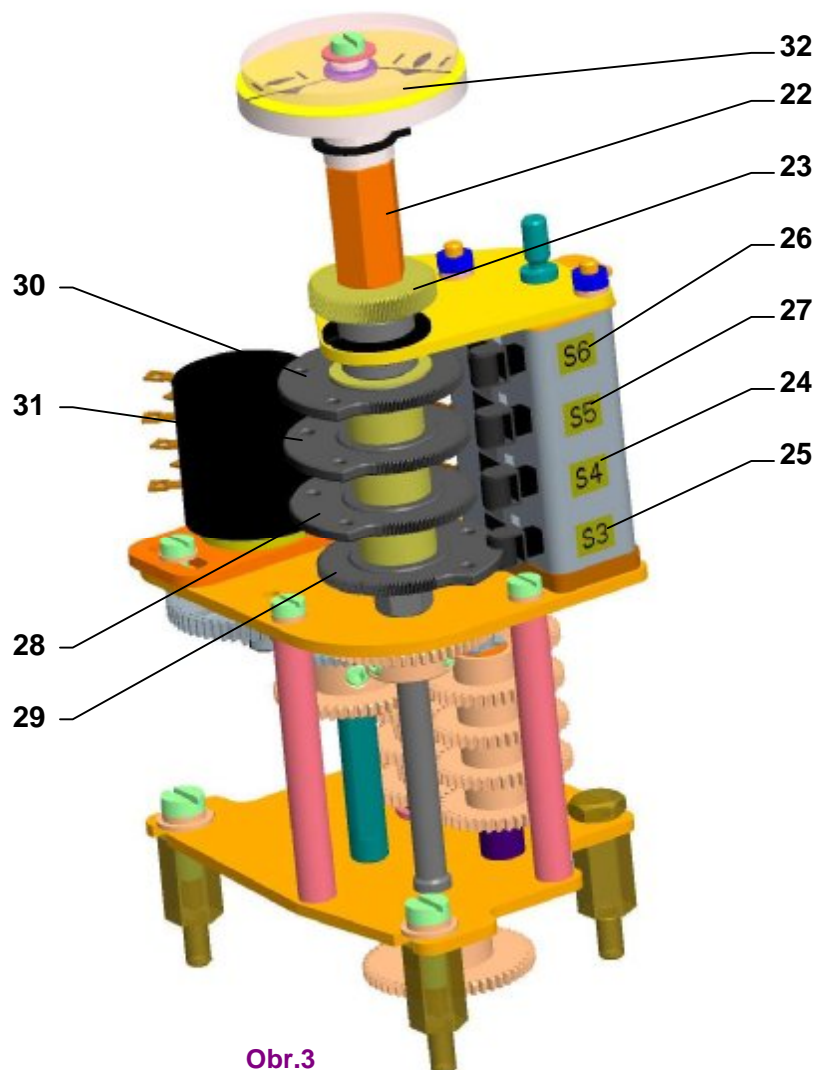

TABLE 5a			
STROKE LINE	STROKE ANGLE	MAX. OPERATING STROKE) FOR UL 1 (mm)	MAX. OPERATING STROKE FOR UL 2 (mm)
I.	1.°	10	3,75
	2.°	20	7,5
	3.°	40	15
	4.°	80	30
	5.°	-	60
	6.°	-	120
II.	1.°	12	5
	2.°	24	10
	3.°	48	20
	4.°	-	40
	5.°	-	80
III.	1.°	15	6
	2.°	30	12
	3.°	60	24
	4.°	-	48
	5.°	-	96

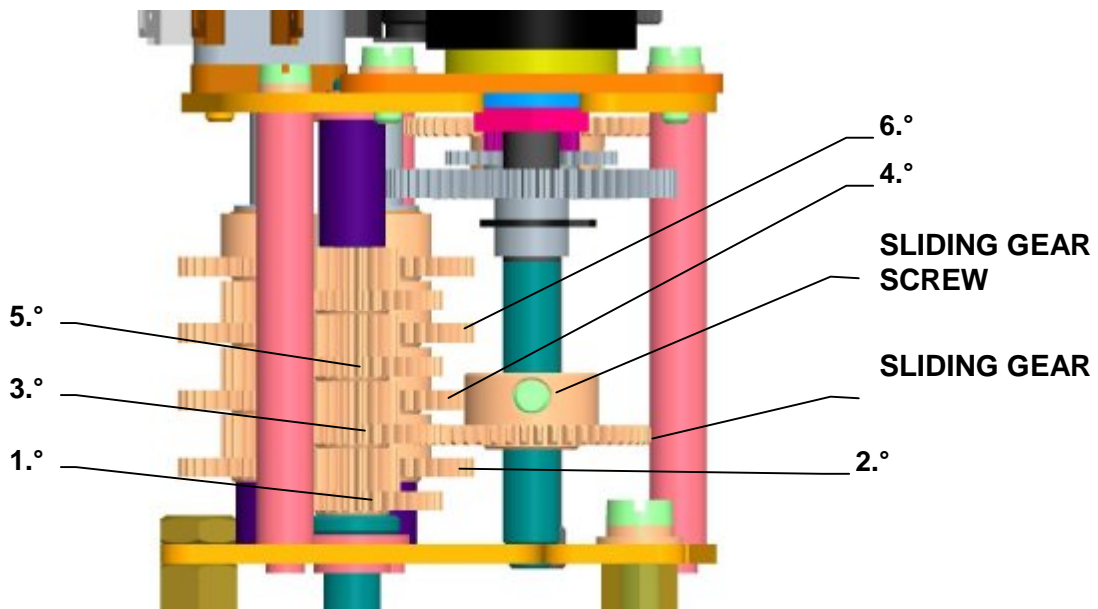

Fig.3c

UL 0 (Fig.3a):

By default the actuator is set by the manufacturer to standard stroke (according to specification), as specified in the nameplate. Unless the customer specifies the value of the particular operating stroke, the stroke is set to **5st degree** of the selected stroke order.

Proceed as follows to adjust, align and reset the limit and signaling switches (Fig.3a).

- set the adjustment wheel to the required degree of the range according to **table 5** and **Fig.3b** by loosening of the adjustment wheel screw and re-tightening after alignment. When adjusting the adjustment wheel, make sure there is correct alignment with the second level disc.
- Reset the actuator to the "opened" position and turn the V3 cam in the clockwise direction (viewing the control panel from the top), until switch S3 is activated
- Reset the actuator to the "closed" position and turn the V4 cam in the counter-clockwise direction (viewing the control panel from the top), until switch S4 is activated
- Reset the actuator to the position at which you want the S5 signaling switch to be activated when moving towards "open" position and rotate cam V5 in the clockwise direction until switch S5 is activated
- Reset the actuator to the position at which you want the S6 signaling switch to be activated when moving towards "closed" position and rotate cam V6 in counter-clockwise direction until switch S6 is activated
- Rotate the position indicator discs for the particular stroke with respect to the gauge mark on the sight of the top enclosure.
- After alignment of the position signaling unit it is necessary (if needed according to the equipment of the actuator) to align the position transmitter.
- *Note 1: Signaling from switches S5, S6 is possible from 40% of the maximum operating stroke adjusted according to **table 5** at the particular gear. If larger signaling range is required, it is possible to make use of the reversing function of the switches.*
- *Note 2: marking switches*
 S3 – position switch „open“
 S4 - position switch „close“
 S5 – position switch (signalling) „open“
 S6 - position switch (signalling) „close“

Note 3: The thrust and position switches are connected in series (see the wiring diagram). If the valve needs to be tightly closed in the limit position by thrust in the corresponding direction, it is necessary to align the corresponding position switch (S3 or S4) so that it does not get activated before the switching-off thrust is reached. Observe the valve manufacturer's instructions when aligning the actuator with the valve!

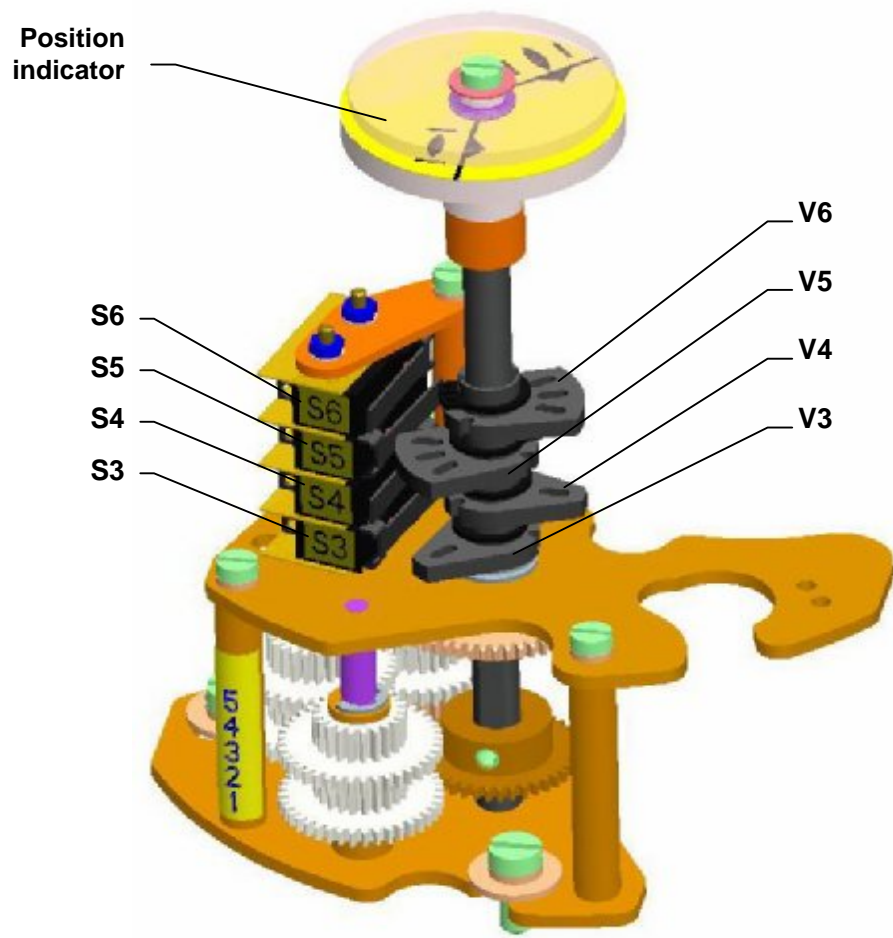

Fig.3a

TABLE 5		
STROKE LINE	STROKE ANGLE	MAX. OPERATING STROKE (mm)
I.	1.°	-
	2.°	4
	3.°	7,5
	4.°	14
	5.°	25
II.	1.°	-
	2.°	5
	3.°	8,5
	4.°	16
	5.°	30
III.	1.°	-
	2.°	6
	3.°	10,5
	4.°	20
	5.°	35
IV.	1.°	-
	2.°	7
	3.°	12,5
	4.°	22,5
	5.°	40

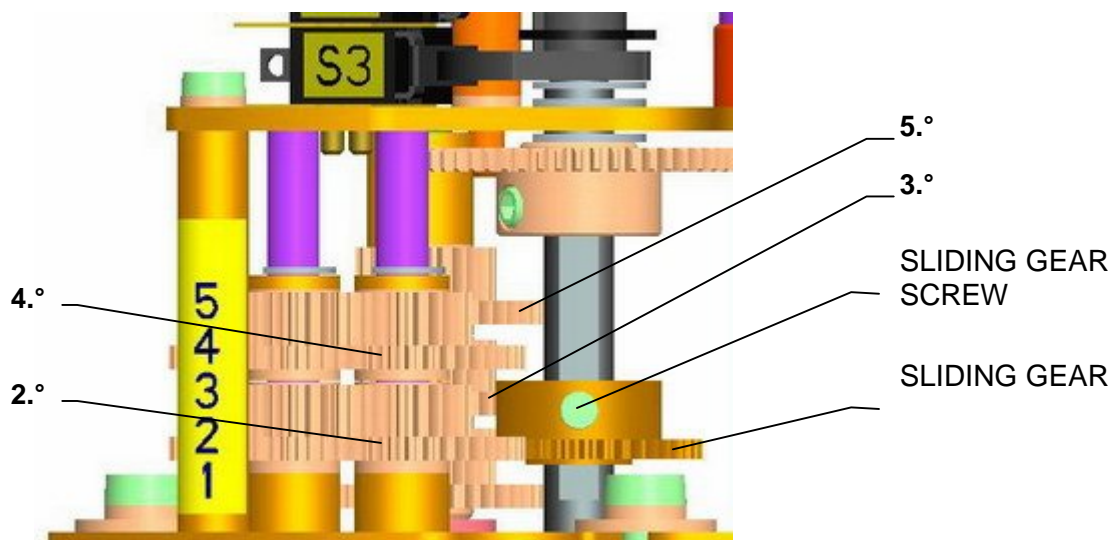

Fig.3b

4.3 Adjustment of resistant transmitter (Fig.4)

The **resistant transmitter** is in the EA **UL 0, UL 1, UL 2** used to function as a remote position indicator.

Before the resistant transmitter adjustment the position switches have to be adjusted (S3, S4).

Adjustment consists in setting of the resistance in the defined limit position of the EA.

Notes:

In case that the EA is unused within the complete operating speed range following the angle selected on the particular stroke line, the "Open" limit position resistance value will undergo proportional reduction.

The transmitters are used with resistance according to the customer's specification. With EA of 2-wire converter a transmitter of 100 W resistance is used.

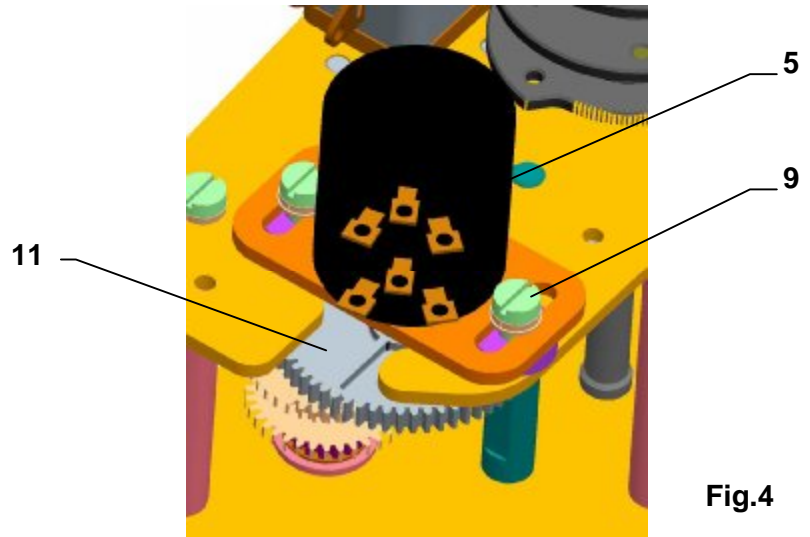

Fig.4

To adjust the transmitter follow these steps:

Loosen the fixing screws (9) of the transmitter holder and push the transmitter out of mesh.

- Put the actuator to the position "closed" (with the handwheel, until the corresponding position switch S2 or S4 switches).
- Connect a meter for resistance measuring to the terminals 71 and 73. Rotate the transmitter shaft (11) until resistance of $\leq 5\%$ of the nominal transmitter resistance can be read on the meter.
- In the position put the transmitter to mesh with the drive wheel and fix the fixing screws on the transmitter holder.
- Please check the resistance value in both of the final positions and in case of need repeat the procedure. Once the device is adjusted in a correct way disconnect the meter from the terminal.

4.4 Adjustment of the Electronic Position Transmitter (EPV) - the Resistive Transmitter (Potentiometer) with the Converter

4.4.1 EPV – the 2-wire version (Fig. 5,5a)

The position transmitter with the converter is in the plant adjusted to have the output current signal on the terminals 81-82 as follows:

- in the position "open" 20 mA
- in the position "closed" 4 mA

If the transmitter requires a new adjustment follow these steps:

Adjustment of the EPV – 2 wire version

- Put the actuator to the position "closed" and switch the power supply off.
- Adjust the resistive transmitter according to the previous chapter. The resistance is to be metered on the terminals X-Y, resp. R-R (Fig. 5,5a). The used transmitter resistance is 100 Ω.
- Switch the converter's power supply on.
- Turn the adjusting trimmer **ZERO** to adjust the output current signal rate measured on the terminals 81-82 to 4 mA.
- Set the actuator to the position "open".
- Turn the adjusting trimmer **GAIN**, resp. **B** to adjust the output current signal rate measured on the terminals 81-82 to **20mA**.
- Check the output signal of the converter in the both limit positions, and repeat the procedure if needed.

Note:

The output signal of 4-20mA can be adjusted at the range from 75 up to 100% of the rated stroke stated on the actuator's nameplate. At values less than 75% the value 20mA is reduced proportionally.

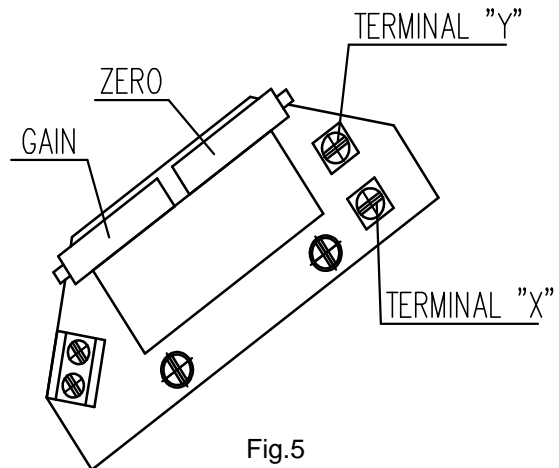

Fig.5

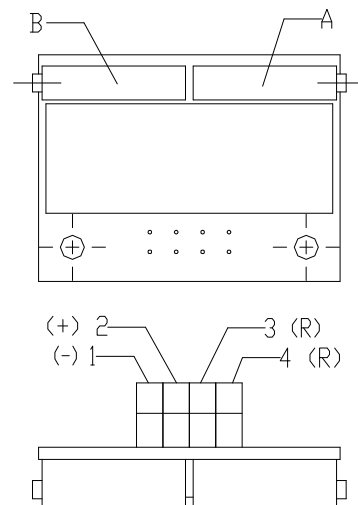

Fig. 5a

4.4.2 EPV – 3-wire version (Fig. 6, 6a)

The resistive transmitter with the converter is in the plant adjusted to have the output current signal metered on the terminals 81-82 as follows:

- in the position "open".....20 mA or 5 mA
- in the position "closed".....0 mA or 4 mA according to the specified version of the converter.

If the transmitter requires a new adjustment follow these steps:

- Put the actuator to the position "closed" and switch the power supply off.
- Adjust the resistive transmitter according to the previous chapter. The resistance is to be metered on the terminals X-Y, resp. 0%-100% (Fig. 6, 6a). The used transmitter resistance is 2000 W or 100 W.
- Switch the converter's power supply on.
- Turn the adjusting trimmer **ZERO**, resp. **A** to adjust the output current signal rate measured on the terminals 81-82 to 0mA or 4 mA, resp. 0V.
- Set the actuator to the position "open".
- Turn the adjusting trimmer **GAIN**, resp. **B** to adjust the output current signal rate measured on the terminals 81-82 to 20mA, resp. 5 mA, resp. 10V.
- Check the output signal of the converter in the both limit positions, and repeat the procedure if needed.

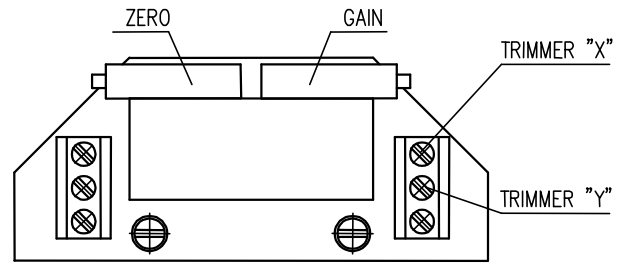

Fig. 6

Note:

The output signal of (0-20mA, 4-20mA or 0-5mA - according to the specification) can be adjusted at the range from 85 up to 100% of the rated stroke stated on the actuator's nameplate. At values less than 85% the value of the output signal is reduced proportionally.

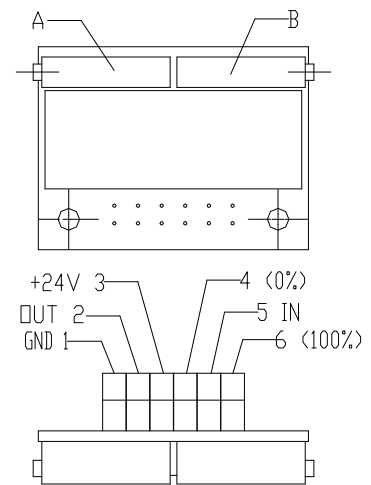

Fig .6a

4.5 Adjustment of Capacitive Transmitter CPT1/A (Fig.7)

The chapter describes adjustment of the capacitive transmitter to the specified parameters (standard values of output signals) in case they are reset. The capacitive transmitter serves as a position transmitter of electric actuators with unified output signal of 4÷20 mA.

Note:

In case that reversed output signals are needed (in the position "OPEN" minimum output signal) contact personnel of service centres.

The capacitive transmitter CPT1/A is adjusted by the producer to the fixed operation angle according to the order and wired according to the wiring diagrams placed into the cover. Check the power supply of the user after connecting to terminal of the terminal board before the transmitter is electrically checked. Adjustment of the capacitive transmitter can be performed when the position switches are adjusted. The adjustment is performed with the power supply of 230 V/50 Hz and ambient temperature of 20± 5°C.

The following versions of electric actuators with built capacitive transmitters can be specified:

- A) The version without any power supply (2-wire version)**
- B) The version with a power supply (2-wire version) for**

A.) Adjustment of the Capacitive Transmitter without any Power Supply

Before connecting check the power supply. The measured voltage should be in range from 18 up to 28 V DC.



The voltage of the power supply **must not be in any case higher than 30 V DC**. The transmitter can be irreversibly damaged!

While checking or adjusting the output signal of 4÷20 mA follow these steps:

- Connect a mA meter of precision class 0,5 and loading resistance lower than 500 Ω serially with the transmitter (pole "-"; terminal 82)
- Put the actuator to the position "CLOSED", the signal value should decrease.
- Check the signal value for the position "CLOSED" (4 mA).
- Tune the signal with loosening the fixing screws (15) and turning the trimmer (10) until the required value of 4 mA is reached. Tighten the fixing screws.
- Put the actuator to the position "OPEN", the signal value should raise.
- Check the signal value for the position "OPEN" (20 mA).
- Tune the signal with turning the trimmer (20) until the required value of 20 mA is reached.
- Check the signal value for the position "CLOSED" and then for the position "OPEN".
- Repeat the procedure until the change from 4 to 20 mA is reached with deviation less then 0,5 %.
- Disconnect the meter and lock the screws with a varnish.

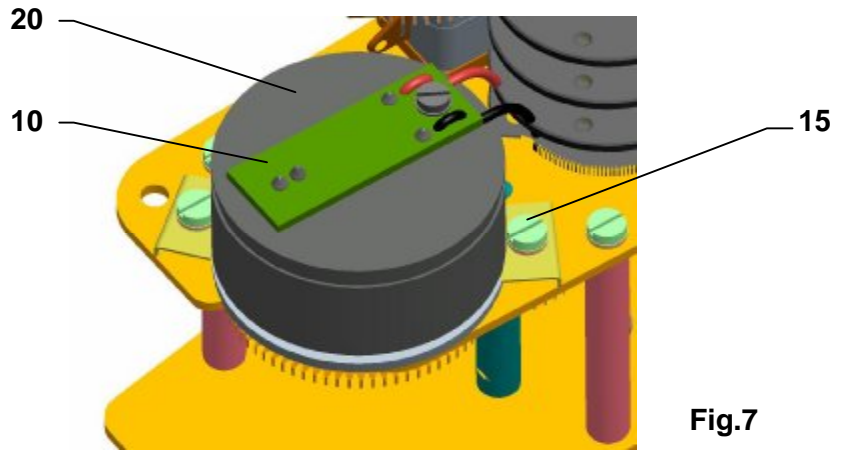

Fig.7

B.) Adjustment of the Capacitive Transmitter with the Power Supply

- 1.) Check the power supply: 230 V AC, resp. 24 V AC (according to version) $\pm 10\%$, on the terminals 1, resp. 60 and 61
- 2.) While checking or adjusting the output signal of 4÷20 mA follow these steps:
 - Connect a mA meter of precision class 0,5 and loading resistance lower than 500 Ω on the terminals 81, 82.
 - Follow the procedure described in the previous chapter A.



The user has to arrange grounding of the 2-wire circuit of the capacitive transmitter to the electrical ground of a joined controller, computer, etc. The grounding should be performed only in one place in any part of the circuit outside the electric actuator!

Note:

The trimmer (20) can be used to adjust the output signal of the capacitive transmitter to any value of operation stroke in range from ca 40% up to 100% of the value of the operation stroke adjusted by the producer and stated on the actuator's nameplate.

4.6 Adjustment of the DCPT3M transmitter

Before the transmitter **DCPT3M (Fig.8)** adjustment the position switches S3 and S4 have to be adjusted. Adjustment consists in setting of the output signal value in the limit positions of the actuator.

By default (unless determined otherwise by the customer), the manufacturer aligns the DCPT3M transmitter so that output signal value 4mA is set for the limit position "closed" and 20 mA for the position "opened". By default the characteristics of the output signal is set to 20-4 mA (descending).

Notes 1: -this type of transmitter enables the assignment 4 mA / 20 mA of the output signal value to any limit position of the actuator.

2: -the transmitter is adjustable within the range of 35 to 100% of the full stroke specified in the nameplate.

4.6.1 Setting of limit positions

If limit positions require re-adjustment, proceed as follows:

Adjustment of the "4 mA" position:

- Turn on the power supply voltage to DCPT3M
- Reset the actuator to the limit position that you want to assign 4 mA signal value to and press (for about 2 seconds) the pushbutton "4", until LED flashes

Adjustment of the "20 mA" position:

- Turn on the power supply voltage to DCPT3M
- Reset the actuator to the limit position that you want to assign 20 mA signal value to and press (for about 2 seconds) the pushbutton "20", until LED flashes

Notes 1: Transmitter error code may result when the first limit position is saved (2x LED flash). The error code is erased by saving of the second limit position, provided that the saved limit positions are within 35 to 100% of the rated stroke specified in the nameplate.

If necessary, please change the characteristic of the output signal from descending to ascending or vice versa, according to the following chapter.

4.6.2 Setting of the ascending/descending characteristic of the output signal

When the characteristic of the transmitter output signal is changed, the set limit positions "4 mA" and "20 mA" are maintained, however the operating range (stroke of DCPT2) between these two positions is changed to the complement of the original operating range.

When the DCPT2 transmitter is set so that output signal value 4mA is set for the limit position "closed" and 20 mA for the position "opened", the characteristic must be set to **20-4 mA (descending)**.

When the DCPT2 transmitter is set so that output signal value 20 mA is set for the limit position "closed" and 4 mA for the position "opened", the characteristic must be set to **4-20 mA (ascending)**.

If you need to toggle the characteristic of the transmitter output signal 4-20 mA (ascending), or 20-4 mA (descending), please proceed as follows:

- Turn on the power supply voltage to DCPT3M
- For **4-20 mA (ascending characteristic)** press the pushbutton "20" and subsequently "4" and hold both buttons pressed until LED flashes.
- For **20-4 mA (descending characteristic)** press the pushbutton "4" and subsequently "20" and hold both buttons pressed until LED flashes.

4.6.3 Calibration MENU

The calibration menu enables setting of default parameters and calibration of current values 4 and 20 mA (fine tuning of the value of the output current signals 4 and 20 mA in the limit positions).

Adjustment of default parameters:

- Turn off the power supply to the transmitter power supply source.
- Press and hold the "4" and "20" adjustment pushbuttons.
- Turn on the power supply to the transmitter power supply source.
- Hold both pushbuttons until the first and on to the second flash of LED.

Caution: By saving the default parameters the calibration of the transmitter is overwritten and therefore the transmitter must be re-calibrated.

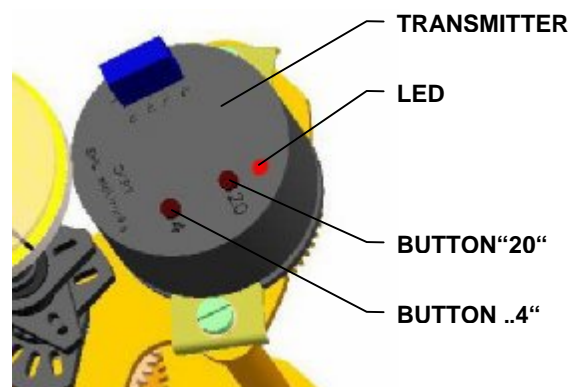

Fig.8

How to access the calibration MENU:

- Turn off the power supply to the transmitter power supply source.
- Press and hold the "4" and "20" adjustment pushbuttons.
- Turn on the power supply to the transmitter power supply source.
- Hold both pushbuttons until the first flash of LED and then release them.

Toggleing between 4 and 20 mA in the calibration mode:

- For 4 mA press the pushbutton "20" and subsequently "4" and hold both buttons pressed until LED flashes.
- For 20 mA press the pushbutton "4" and subsequently "20" and hold both buttons pressed until LED flashes.

Setting of 4/20 mA current values in the calibration MENU:

- To reduce the current value, press "20". By holding the button depressed, auto repeat is activated to continuously reduce the value of the output current and when the button is released, the actual value is saved.
- To increase the current value, press "4". By holding the button depressed, auto repeat is activated to continuously increase the value of the output current and when the button is released, the actual value is saved.

4.6.4 Transmitter error messages

Error is indicated by flashing LED. The number of repeated LED flashes indicates the error code as per **table 6**.

TABLE 6	
Number of LED flashes	Error
1x	Transmitter position outside operating range
2x	Incorrectly set operating range for the transmitter angle of rotation
3x	Tolerance level of magnetic field outside permitted range
4x	Incorrect parameters in EEPROM
5x	Incorrect parameters in RAM

4.7 Electric local control (Fig.15)

- additional equipment

If necessary (accession, function check and so on), it is possible to preset EA by local electric control with secured power feeding. Upon switching the local control to "LOCAL" mode, it is possible to use OPEN and CLOSE buttons to control the movement of the output element in the entered direction. LEDs indicate individual modes of the local control.

The control is possible after removing the padlock (1). Control mode selection is changed by sequential pressing of the button (2) **REMOTE-OFF-LOCAL** to "Remote" "Shut off", "Local", "Shut off". Individual modes are cycled by sequential pressing. The selection is indicated by LEDs visible on the front panel of the local control.

LED**PWR** (6) indicates the presence of supply voltage to control the local control.

Individual local control modes:

The „**OFF**“ mode - this mode does not enable remote or local control of EA. The mode is indicated by LEDs **REMOTE** (7) and **LOCAL** (8) being off

The „**LOCAL**“ mode - this mode enables EA control in the open and close direction and to stop using buttons **OPEN** (3) (open), **CLOSE** (4) (close) and **STOP** (5). The „**LOCAL**“ mode is indicated by **LOCAL** (8) LED being lit. When **OPEN** button is pressed in this mode, it is indicated by **OPEN** LED being lit (9). When **CLOSE** button is pressed in this mode, it is indicated by **CLOSE** LED being lit (10). When **STOP** button is pushed, the signal LEDs **OPEN** (9) and **CLOSE** (10) are switched off.

The „**REMOTE**“ mode - in this mode the EA can be remotely controlled by commands from master system. The „**REMOTE**“ mode is indicated by **REMOTE** (7) LED being lit. In this mode the OPEN, STOP and CLOSE buttons are not functional.

After finishing the work with electrical local control, we recommend to return the padlock to button (2) in mode „**REMOTE**“ and lock out the device to avoid unwanted tampering by unauthorized person.

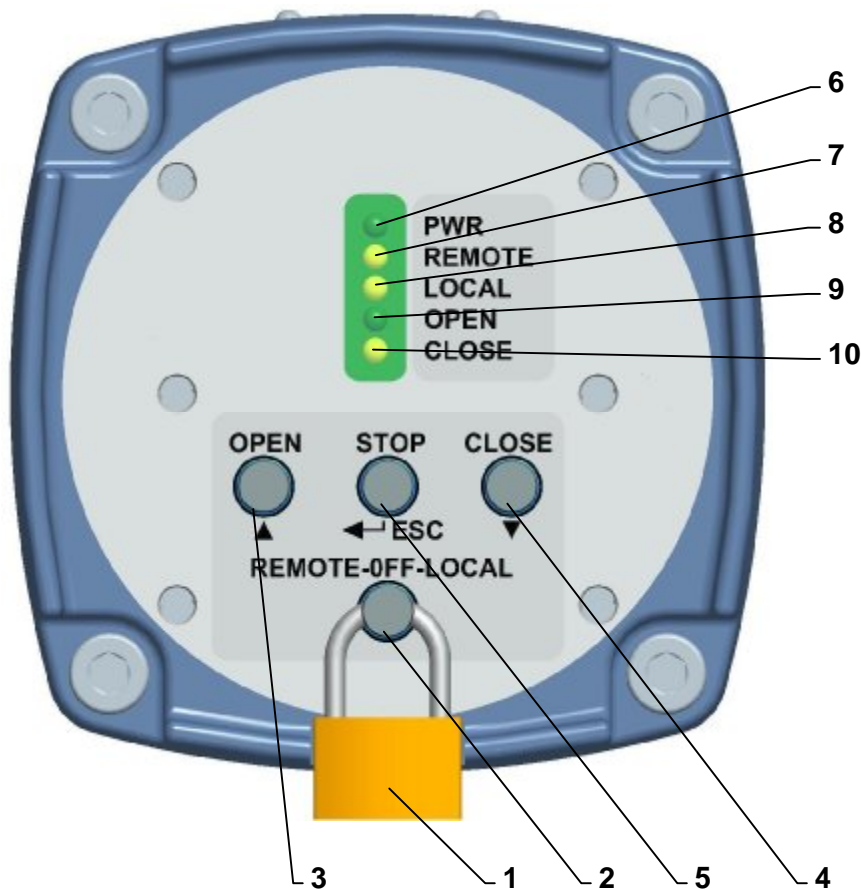

Fig. 15

5. Service and Maintenance

5.1 Service



1. *In general it is supposed that the EA is serviced by a qualified person as required in the Chapter 1!*
2. *After the EA is put into operation it is necessary to check whether during manipulation its surface finishing was not damaged – the damages should be eliminated to prevent the surface against deterioration caused by corrosion!*

- The EA requires just an insignificant service. The reliable operation is determined by the correct putting into operation.
- The service of the EA results from the operation conditions and generally consists in treating the information for subsequent performing of a required function. The EA can be controlled by remote control electrically or manually on the place of their installation. The manual control is available with a handwheel.
- The service staff should arrange the required maintenance and prevent the actuator during operation against impacts of environment and climate what exceed the frame of allowed influences stated in the Chapter "Operation Conditions".
- It is necessary to avoid overheating of the EA surface, exceeding of parameters stated on the nameplate and abnormal vibrations of the EA.

Manual control:

- If the manual control is needed (adjustment, function checking, failures etc.) the staff can reset the regulated member using the handwheel. While rotating the handwheel clockwise the output element moves in the direction "CLOSING".

5.2 Maintenance - extent and periodicity

All screws and nuts affecting tightness and protection (IP) must be tighten during the inspection and maintenance. Similarly, once a year should be checked and if necessary tighten mounting screws of the terminal wires and assuring of the slip-on joints with wires.

The interval between two preventive inspections is four years.

In case of damage or after 6 years of the actuator's operation the replacement of cover seals and oil filling seals must be done.

The grease in the supplied actuators is designed for the lifetime of the product.

It is not necessary to change the grease during the operation of the actuator.

During inspection, replace the sealing O-ring (see Chapter 6) between the bottom and top cover - replace with original O-ring from manufacturer.

Lubrication:

- - gear part - in versions for climate with temperatures -25°C till $+55^{\circ}\text{C}$ – grease HF 401/0 (GLEIT- μ) resp. GLEITMO 585 K
- in versions for climate with temperatures -50°C till $+40^{\circ}\text{C}$ grease ISOFLEX TOPAS AK 50
- in versions for climate with temperatures -60°C till $+40^{\circ}\text{C}$ grease DISCOR R-EP 000
- - linear adapter – grease GLEIT- μ - HP 520M (to -25°C) resp. HP 520S (to -60°C).



Lubrication of the valve stem is independent on maintenance of the EA!

After every potential flooding of the product check, whether there is no water inside. After eventual water penetration, dry the product before repeated putting into operation and replace damaged sealings, resp. other parts of EA. identically check also tightness of cable bushings and replace them, if they are damaged.

- Every six months it is recommended to perform one check move in frame of adjusted operation stroke to verify reliability of functioning with setting back to the original position.
- If the audit rules do not determine else the inspection of EA is performed ones a year and tightening of all connecting and grounded screws have to be checked to avoid overheating.
- After 6 months from putting of EA into operation and once a year it is recommended to check tightening of fixing screws between the EA and the valve. (Tighten the screws with the cross system.)



- While connecting and disconnecting of the EA check the tightness of cable glands – those with damaged sealings should be replaced by new ones of the approved type!
Keep the EA clean and take care about removing impurities and dust. The cleaning has to be performed regularly according to the operation possibilities and requirements.

5.3 Maintenance to assure protection

- The fixing screws of the upper cover have to be always in full numbers, i.e. 4 pcs, with flexible washers and tightly fastened.
- While connecting and disconnecting of the EA check the sealing rings of the cable leads – damaged and worn sealing should be replaced by original rings!
- Keep the EA clean and take care about removing impurities and dust. The cleaning has to be performed regularly according to the operation possibilities and requirements.



Caution:

After disassembly and re-assembly of top enclosure and bottom enclosure (if any damage occurs) the sealing O-ring must be replaced according following table:

O- Ring	Dimension	Standard	PNm	Material	Manufacturer
Bottom enclosure and top enclosure (UL 0-Ex)	134,5x3	AS 568 B/BS 1806	62 732 XXX	NBR	TRELLEBORG SEALING SOLUTIONS
Bottom enclosure and top enclosure (UL 1-Ex)	180x3	AS 568 B/BS 1806	62 732 XXX	NBR	
Bottom enclosure and top enclosure (UL 2-Ex)	202,79x3,53	AS 568B/B S 1806	62 732 XXX	NBR	
Local control	105x3	STN 02 9281.9	62 732 390	MVQ	Rubena Náchod

5.4 Troubleshooting

- In case of a mains failure the EA stands in the position where it was before the failure occurred. If needed the EA can be reset using the manual control (with the handwheel). When necessary EA can be manually operated (handwheel), at doing this, pay attention to keep the movement of the EA output part within the range of the set stroke so as to avoid losing the adjustment of the limit position switches or position transmitter or regulator. After supply voltage recovery EA is prepared for operation.
- In case of a failure of a part of the EA the part can be replaced by a new one. The exchange is to be committed by the producer or a contracted service firm.
- In case of an EA failure, which cannot be eliminated directly in operation, follow instructions for under-guaranty and after-guaranty service.

Table 7

Failure	Cause	Troubleshoot
There are no revolutions of motor rotor when operating the push-buttons.	1. No voltage on the electric motor connectors.	Check connection and voltage presence.
	2. No voltage on the control part.	Check connection of the control part.
The EA fails to stop at the limit positions.	1. Incorrect setting-up of the switches.	Perform adjustment.
	2. The microswitch is defective	Replace the microswitch for a new one and adjust.
	3. Incorrect actuator connection	Check connection of position and torque switches in control circuit
The EA stops at the mid-position.	There is an obstacle in the valve or part of it seizes.	Perform reversing of the EA, move it to the original direction and, in the case that the failure repeats, repair the armature.
There is no indication of reaching these positions in the final positions.	1. The LEDs fail to operate.	Replace the LEDs for new ones.
	2. Incorrect adjustment of the position signal switches.	Adjust the position signal switches.
		In case that some EA failures still remain, contact the service centres.

- *Note: If the EA has to be dismantled follow the procedure of the Chapter "Dismantling"*



The EA can be dismantled to be repair purpose by qualified and trainer persons only! The training can be preformed by the producer or by a contracted service firm.

6. Accessories and Spare Parts

As accessories the **handwheel** is packed with the product.

6.1 List of the Spare Parts

Spare part	Order Nr.	Position	Figure
Electric motor; 13,8 W; 230 VAC; (UL 0)	63 592 408	2	1
Electric motor; 13,8 W; 24 VAC; (UL 0)	63 592 413	2	1
Electric motor; 53 W; 24 VAC; (UL 1)	63 592 XXX	2	1
Electric motor; 100 W; 24 VAC; (UL 2)	63 592 XXX	2	1
Electric motor; 40 W/90 VA; 230V AC; (UL1)	63 592 076	2	1
Electric motor; 40 W/110 VA; 3x400V AC; 3x415V AC; (UL1)	63 592 054	2	1
Electric motor; 120 W/228VA; 230V AC; (UL 2)	63 592 394	2	1
Electric motor; 60 W/120VA; 230V AC; (UL 2)	63 592 322	2	1
Electric motor; 180 W/300VA; 3x400V AC; 3x415V AC; (UL 2)	63 592 330	2	1
Electric motor; 90 W/150VA; 3x400V AC; (UL 2)	63 592 328	2	1
Electric motor; 13,8 W/14,2W; 120 V AC; 50Hz /60Hz; (UL 0)	63 592 412	2	1
Electric motor; 40 W/90 VA; 115 V AC, 60 Hz; (UL 1)	63 592 XXX	2	1
Electric motor; 70 W/125VA; 120 V AC, 60 Hz; (ULR 2PA)	63 592 XXX	2	1
Elektromotor; 120 W/228VA; 120 V AC, 60 Hz; (ULR 2PA)	63 592 XXX	2	1
Electric motor; 7,5 W; 3x400 V AC; 50Hz; 3x400V AC; (UL 0)	63 592 XXX	2	1
Electric motor; 6,2 W; 3x400 V AC; 60Hz; 3x400V AC; (UL 0)	63 592 XXX	2	1
Electric motor; 6,5 W; 3x400 V AC; 50Hz; 3x400V AC; (UL 0)	63 592 XXX	2	1
Electric motor; 7 W; 3x400 V AC; 60Hz; 3x400V AC; (UL 0)	63 592 XXX	2	1
Electric motor; 15 W; 3x400 V AC; 50Hz; 3x400V AC; (UL 0)	63 592 XXX	2	1
Electric motor; 13 W; 3x400 V AC; 60Hz; 3x400V AC; (UL 0)	63 592 XXX	2	1
Capacitor 0,82μF (UL 0)	63 540 002 63 540 007	2	1
Capacitor 82μF (UL 0)	63 540 006 63 540 003	2	1
Capacitor 5μF (UL 1)	63 540 001	2	1
Capacitor 7μF (UL 2)	63 540 181	2	1
Capacitor 8μF (UL 2)	Súčasť motora	2	1
Capacitor 3,3μF (UL 0)	63 542 038	2	1
Capacitor 9μF (UL 1)	Súčasť motora	2	1
Capacitor 16μF (ULR 2PA)	63 540 251	2	1
Capacitor 20μF (ULR 2PA)	63 540 252	2	1
Microswitch DB 6G A1LB (UL 0)	64 051 466	S3,S4,S5,S6	3a
Microswitch DB3C-A1 (gold-plated contacts) (UL 0)	64 051 200	S3,S4,S5,S6	3a
Microswitch D443-S1LD (UL 2)	64 051 737	24,25,26,27	3
Microswitch D383-Q3RA (UL1-Ex, UL 2)	64 051 738	24,25,26,27	3
Microswitch D413-V3 RA (gold-plated contacts) (UL 1, UL 2)	64 051 470	24,25,26,27	3
Capacitive transmitter CPT 1	64 051 499	10	7
Resistant wire transmitter (potentiometer) RP19; 1x100	64 051 812	5	4
Resistant wire transmitter (potentiometer)RP19; 1x2000	64 051 827	5	4
Resistant wire transmitter (potentiometer)RP19; 2x100	64 051 814	5	4
Resistant wire transmitter (potentiometer)RP19; 2x2000	64 051 825	5	4
Transmitter DCPT3M	64 051 059	-	8
Power supply DX3004.P24	64 051 184	-	-
Ring 134,5x3 SMS 1586; BS 4518 (UL 0)	62 732 XXX	-	-
Ring 180x3 AS 568 B/BS 1806 (UL 1)	62 732 XXX	-	-
Ring 202,79x3,53 AS 568 B/BS 1806 (UL 2)	62 732 XXX	-	-
O-Ring 105 x 3	62 732 390	-	-
Steering ring 22 (UL 0)	STN 029295 62 732 014	-	-
Ring 30x22 MVQ (UL 0)	STN 029280.9 62 731076	-	-
Steering ring 28 (UL 1)	STN 029295 62 732 255	-	-
Steering ring 28x35,6x4,2 (UL 1)	62 732 391	-	-
Ring 36x28 MVQ (UL 1)	STN 029280.9 62 732 338	-	-
Steering ring 40 (UL 2)	62 732 164	-	-
Steering ring 40x48,8x6,3 (UL 2)	62 732 158	-	-
O-ring 44,12x2,62 (UL 2)	62 732 157	-	-
Ring 50x40 MVQ (UL 2)	STN 029280.9 62 732 404	-	-



The disassemble of EA for the purpose of repair is possible only for the manufacturer!

7. Enclosures

7.1 Wiring diagrams UL 1, UL 2

Electrical connection to the terminal block:

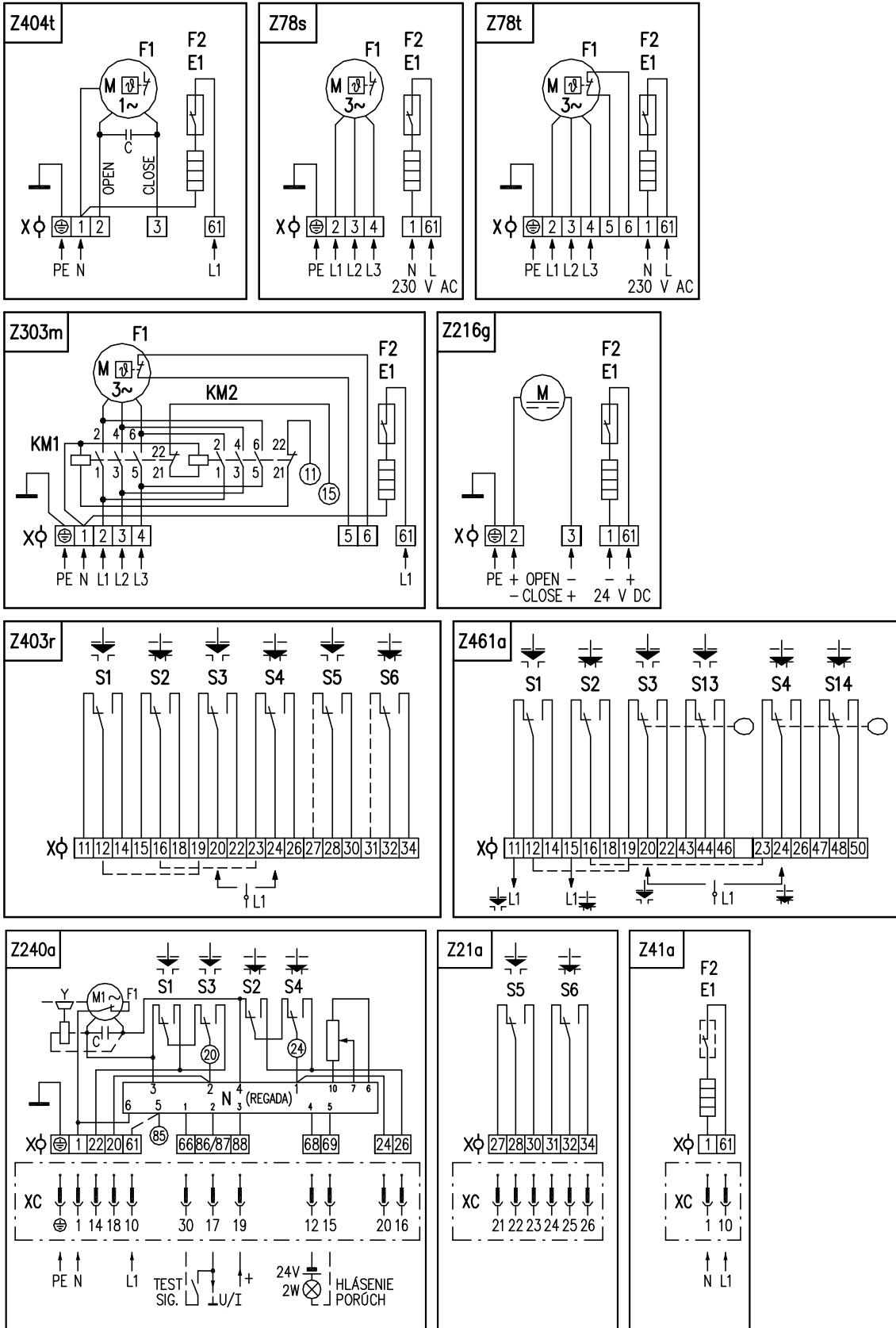

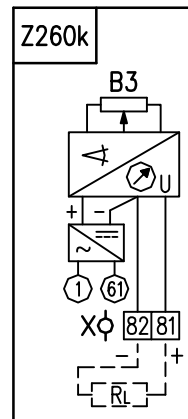
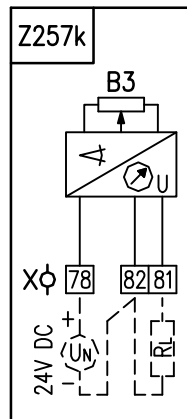
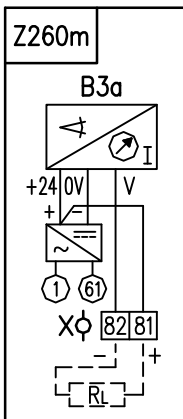
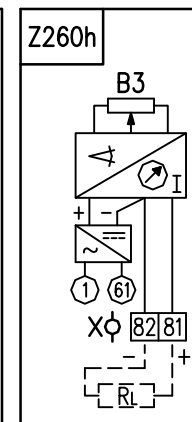
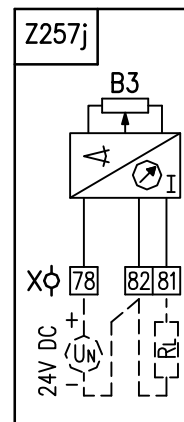
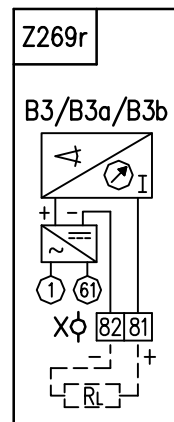
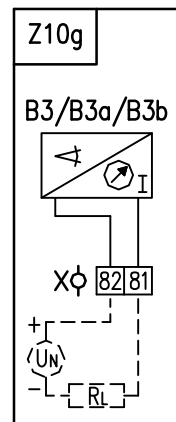
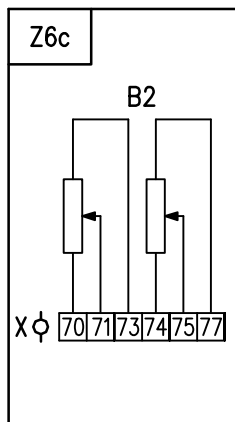
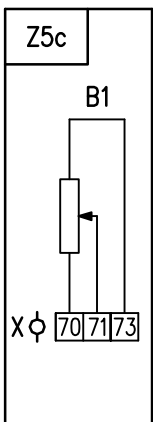
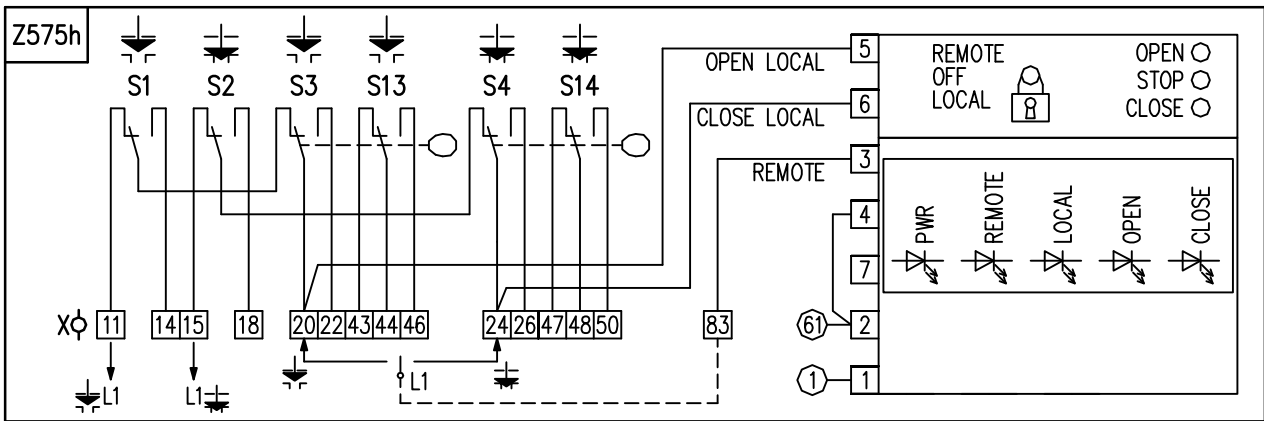
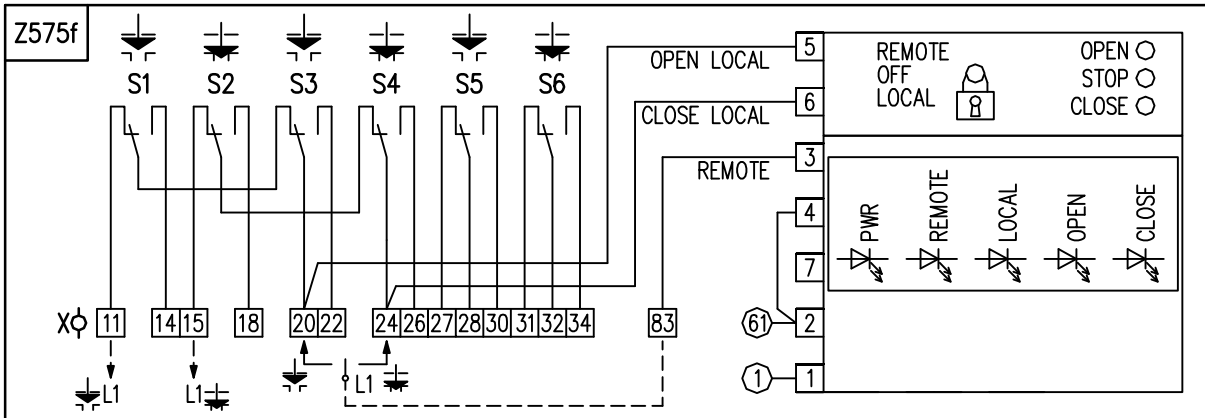

Electrical connection to the connector:

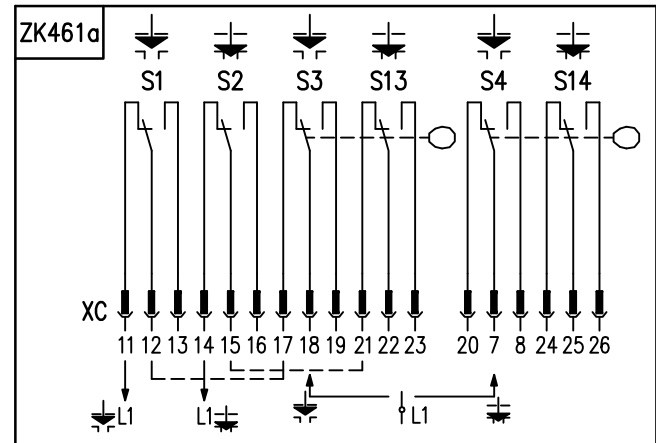
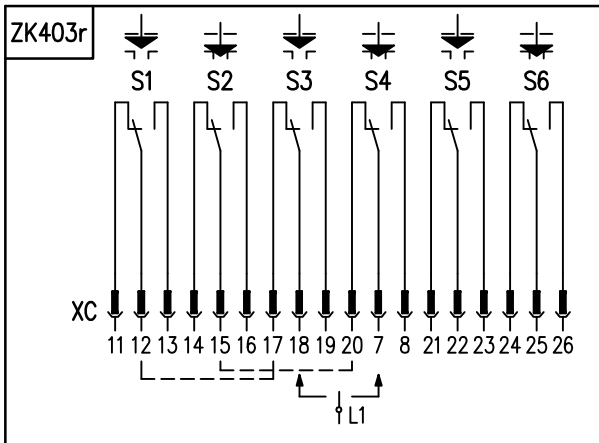
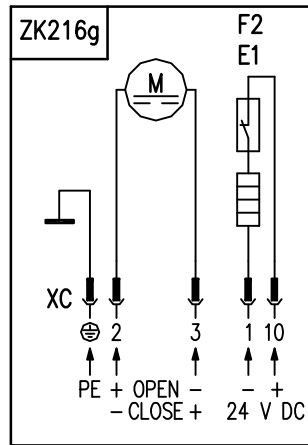
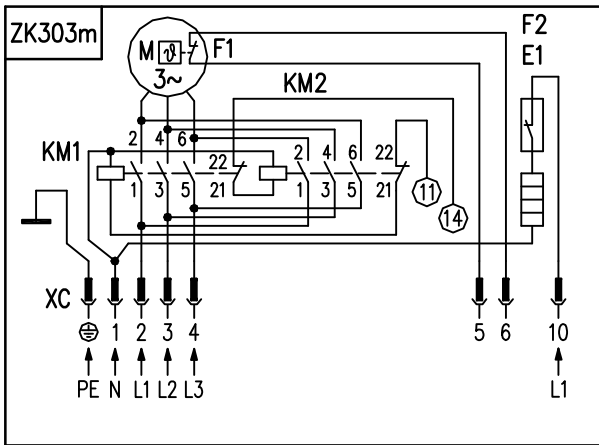
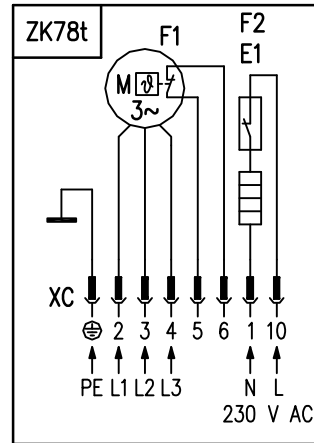
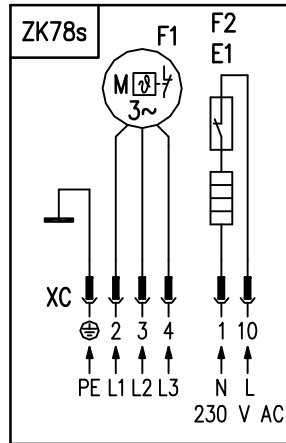
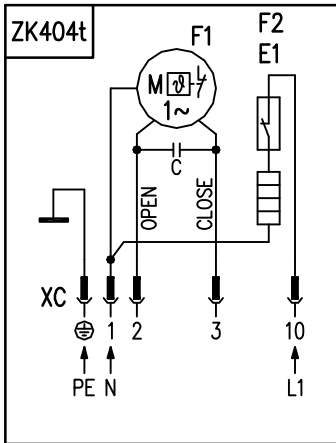

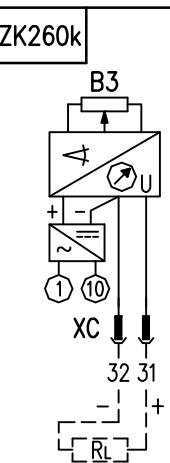
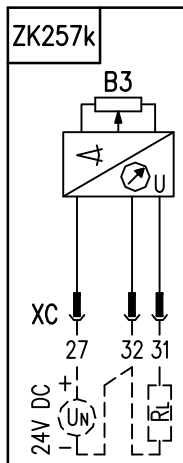
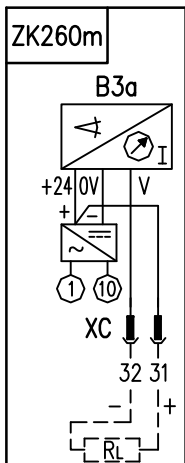
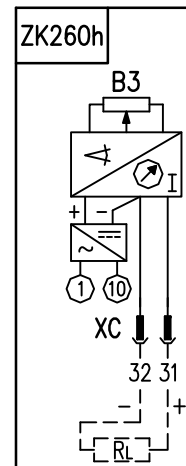
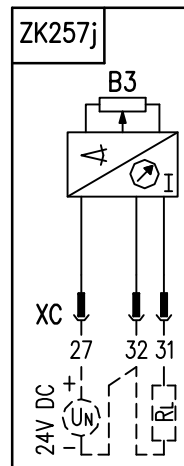
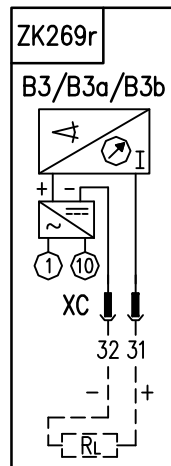
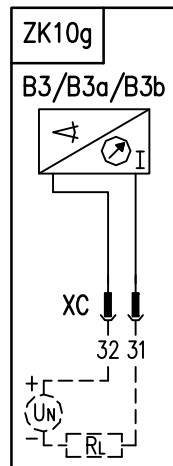
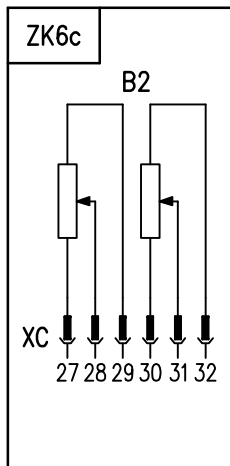
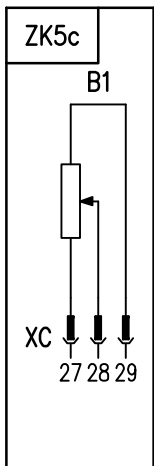
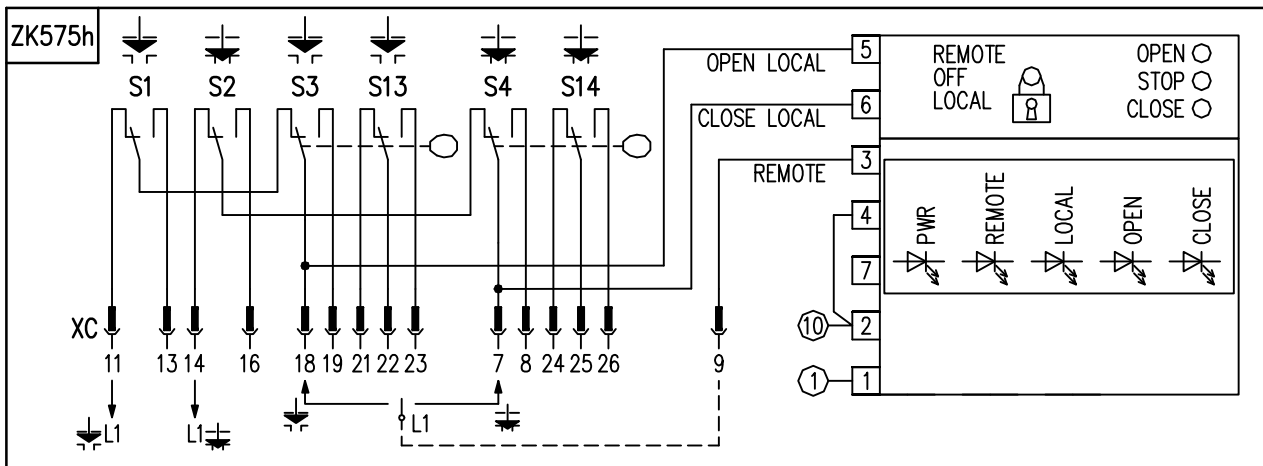
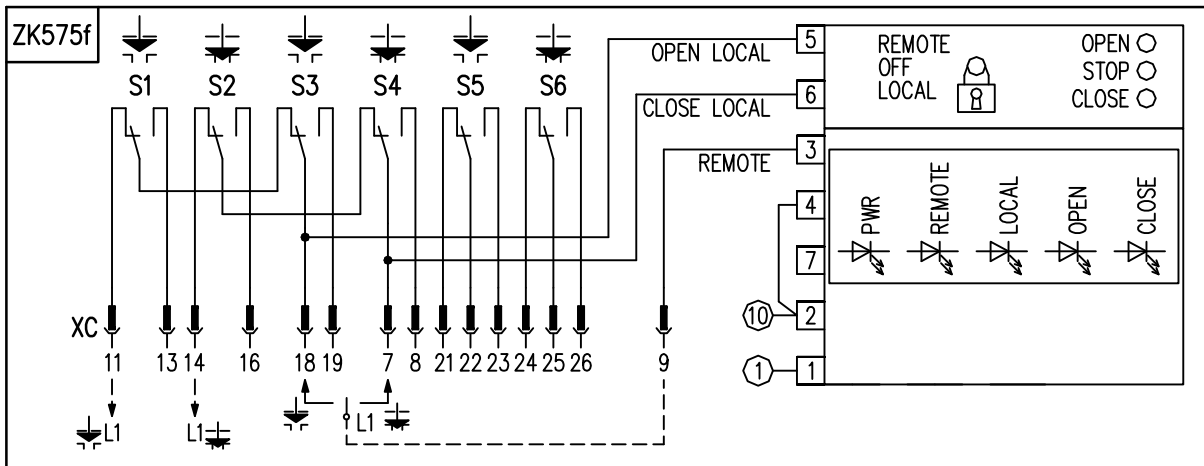

7.2 Wiring diagrams UL 0

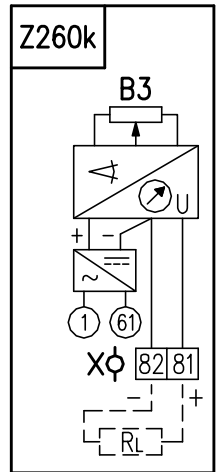
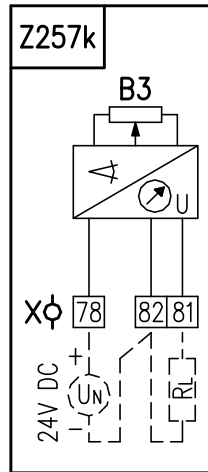
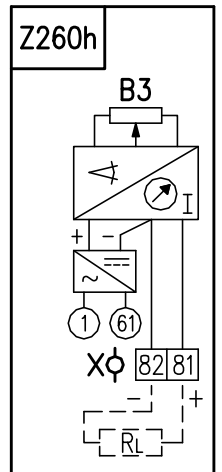
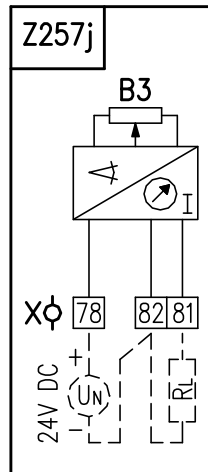
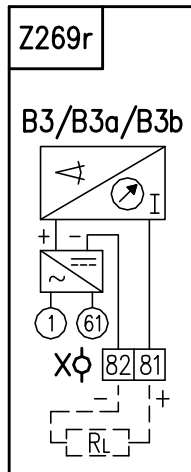
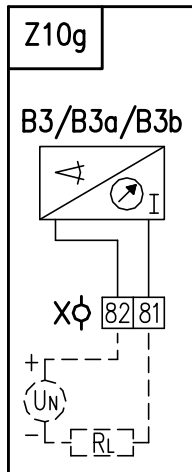
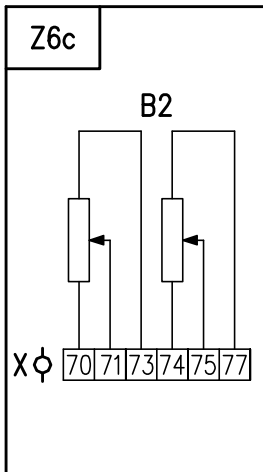
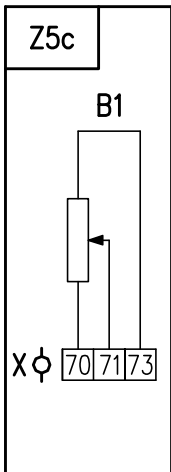
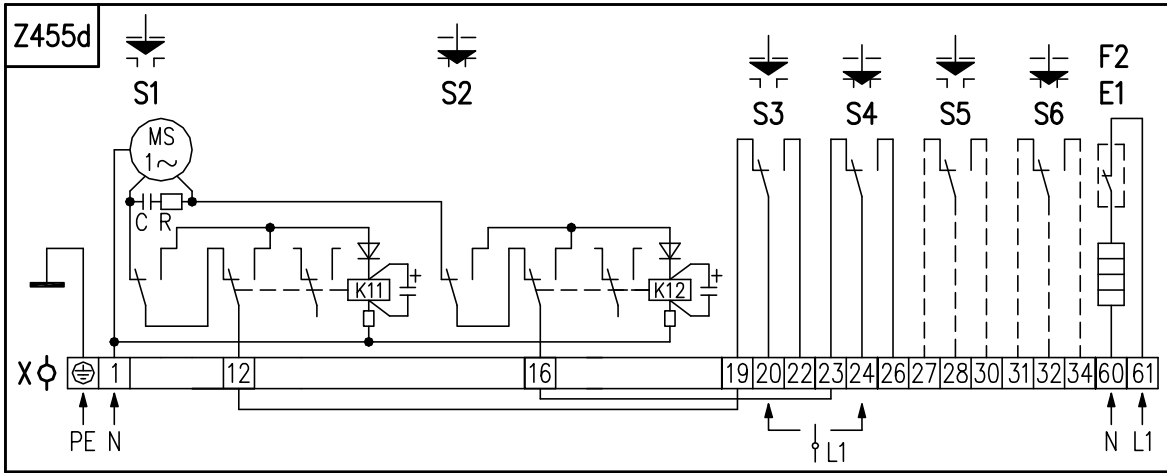

Legend:

Z5c, ZK5c.....wiring diagram of single resistant transmitter
 Z6c, ZK6c.....wiring diagram of double resistant transmitter
 Z10a, Z10g, ZK10g....wiring diagram of resistive with current controller or capacitive transmitter -
 2 - wire without supply
 Z455d, ZK455dwiring diagram of electric motor with thrust and position switch and with space heater
 Z78s, ZK78s,wiring diagram of 3-phase electric motor and space heater
 Z78t, ZK78t,wiring diagram of 3-phase electric motor and space heater
 Z303m, ZK303mwiring diagram of EA 2 with 3~ phase electric motor with reverse contactor
 Z257j, ZK257j3-wire version of EPV - without power supply connection
 Z260h, ZK260h3-wire version of EPV – with power supply connection
 Z269r, ZK269r.....2-wire version of EPV – with power supply connection
 Z403r, ZK403r.....wiring diagram of force and position switches
 Z404t, ZK404twiring diagram with 1~ phase electric motor
 Z575f, ZK575fwiring diagram of force and position switches and local control.
 Z241a.....wiring diagram with controller with current feedback for 1-phase electric motor
 Z41awiring diagram of space heater and space heater's thermal
 Z21a.....wiring diagram of additional position switches connectio

B1.....resistive transmitter (potentiometer) single	C..... capacitor
B2.....resistive transmitter (potentiometer) double	Y..... brake of electric motor (valid for EA UL 2-Ex)
B3.....capacitive transmitter	E1..... space heater
S1..... thrust switch "open"	K11,K12 coil of relay
S2..... thrust switch "closed"	KM1, KM2 .. coil of contactor (valid for EA UL 2-Ex)
S3..... position switch "open"	F1 electric motor thermal protection
S4..... position switch "closed"	F2..... space heater thermal switch
S5..... additional position switch "open"	X, X2 terminal board
S6..... additional position switch "closed"	XC connector (is not valid for these types EA)
ReS11relay of thrust of switch S1	I/U..... output current (voltage) signal
ReS12relay of thrust of switch S2	R _L loading resistor
M, MS.....electric motor	R..... reducing resistor (valid for EA UL 0)

Note 1: Thermal protection of single-phase electric motor (Z404t) is standardly built-in in electric motor, on the neutral wire.

Note 2: Force switching is not fitted with mechanical interlocking device.

Note 3 : Jumpers 12-19 and 16-23 terminal board in wiring diagram Z455d are standardly delivered from the producer.

7.3 Operation Logic Diagram of switches and relays

Switch	Terminal Nr.	open		closed	
		Operating stroke			
S1	11 (M2) - 12				
	12 - 14*				
S2	15 (M3) - 16				
	16 - 18*				
S3	19 - 20				
	20 - 22				
S4	23 - 24				
	24 - 26				
S5	27 - 28				
	28 - 30				
S6	31 - 32				
	32 - 34				
ReS11	35 - 36				
	36 - 38				
ReS12	39 - 40				
	40 - 42				

 Contact connected

 Contact disconnected

Note 1: Signaling from switches S5, S6 for EA UL 0, is possible from 40% of the maximum operating stroke adjusted (mentioned in the nameplate) before end position. If larger signaling range is required, it is possible to make use of the reversing function of the switches.

*Note 2: *- contacts 11,14 and 15,18 of switches S1 a S2 for EA model UL 0 have not been taken out to the terminal board. For EA model UL 1 and UL 2 contacts 14 and 18 have not been taken out.*

Note 3: Relay ReS11 switches simultaneously with switch S1 and relay ReS12 switches simultaneously with switch S2.

7.4 Dimensional drawings

Electric linear actuators **UL 0**

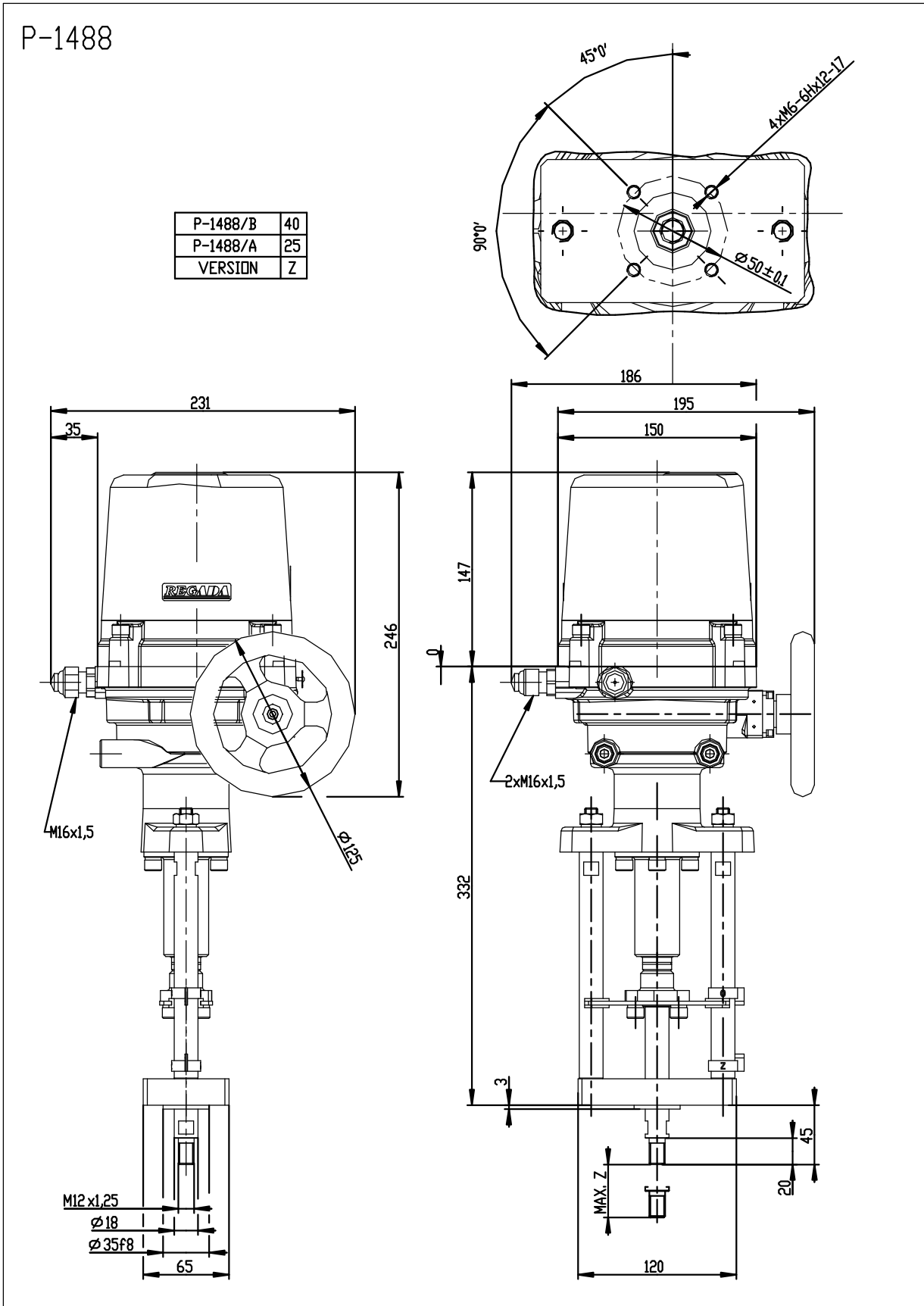

P-1489

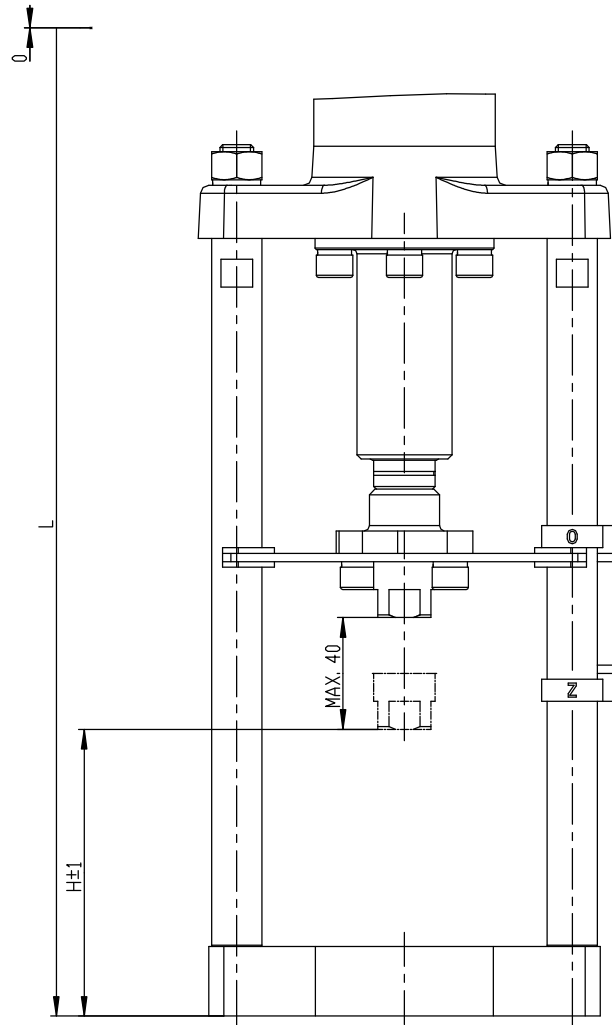

P-1489/G	86	402
P-1489/F	59	375
P-1489/E	102	420
P-1489/D	94	410
P-1489/C	112	428
P-1489/B	112	428
P-1489/A	103	419
VERSION	H	L

P-1489/A

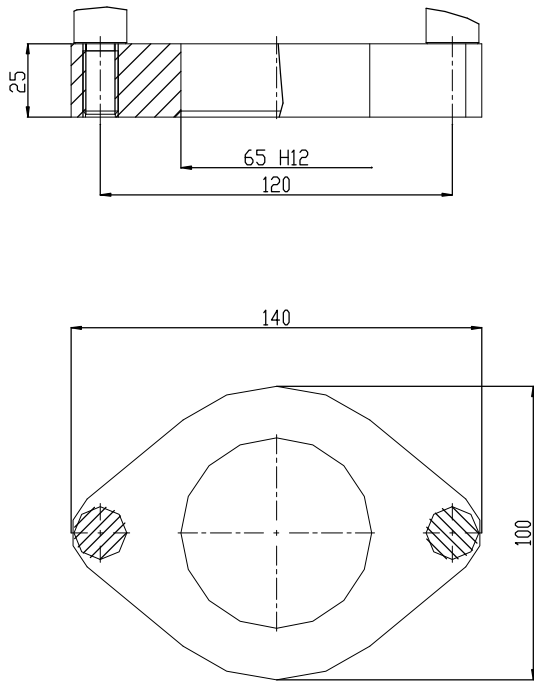

P-1489/B

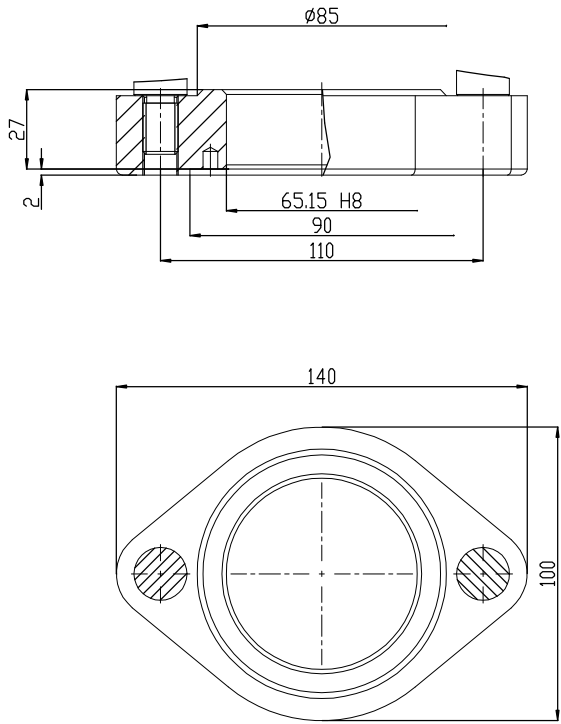

P-1489/C

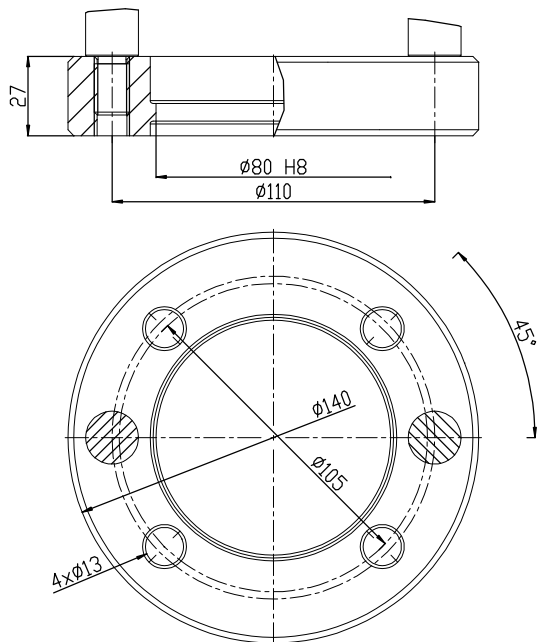

P-1489/D; E

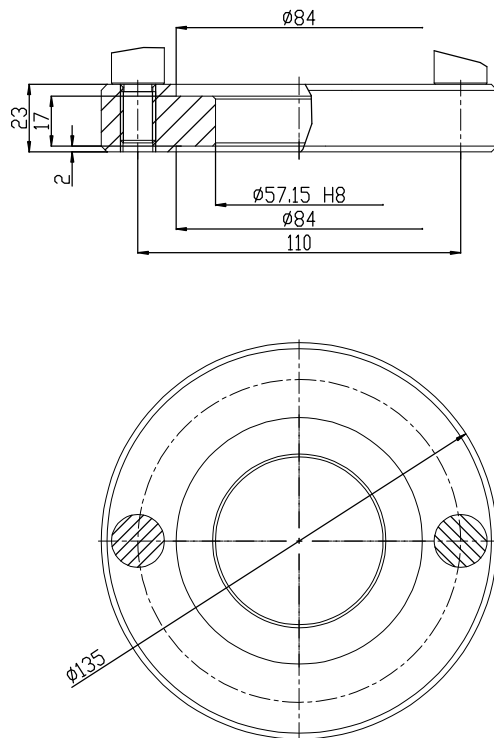

P-1489/F; G

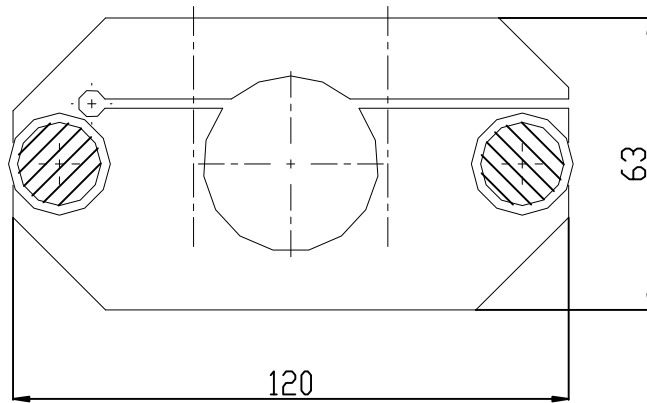
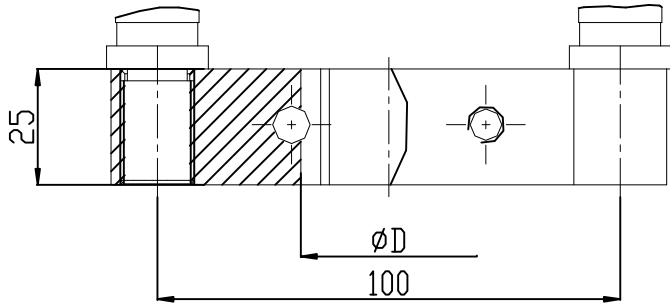

P-1489/G	60
P-1489/F	38
VERSION	D

P-1490/A; B; C

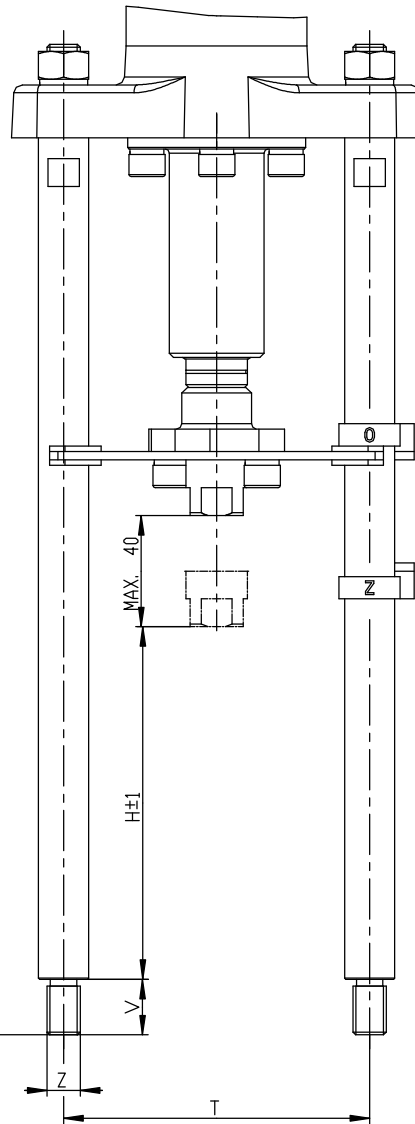

P-1490/C		80		32	426
P-1490/B	110	42	M12	20	378
P-1490/A		127			463
VERSION	T	H	Z	V	L

P-1490/D; E; F

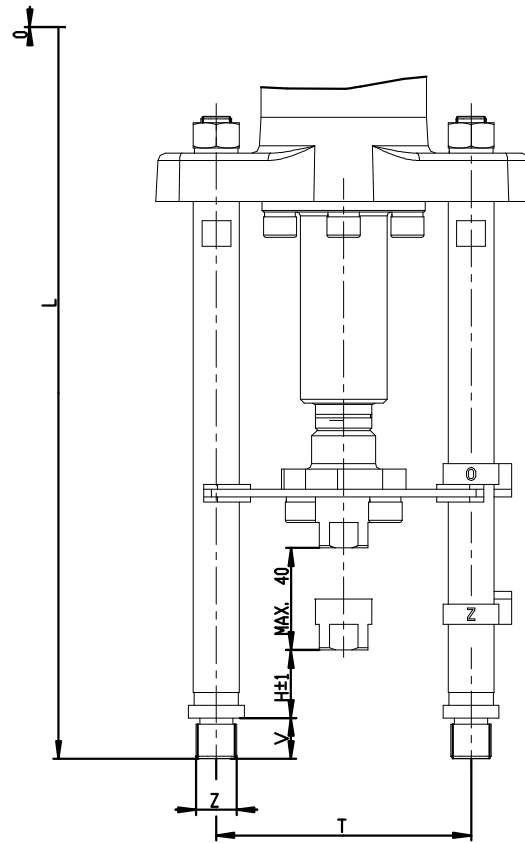

P-1490/F		110			442
P-1490/E	100	57	M16	16	389
P-1490/D		27			359
VERSION	T	H	Z	V	L

Electric linear actuator **UL 1**

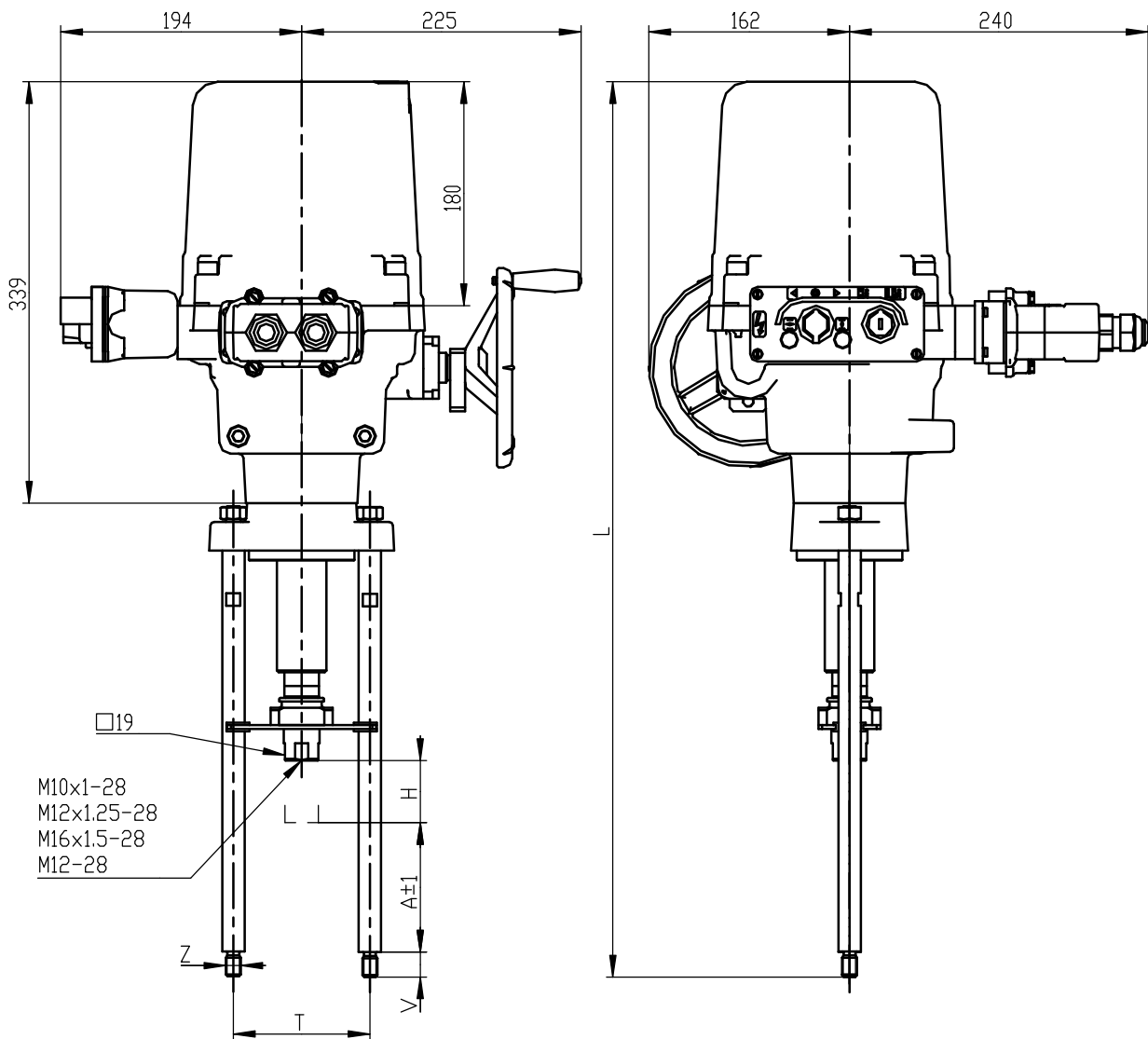

110	MAX. 50 (80)	100	M16	16	726
57		100	M16	16	673
27		100	M16	16	643
80		110	M12	32	696
42		110	M12	20	658
127		110	M12	20	743
A	H	T	Z	V	L

P-2053

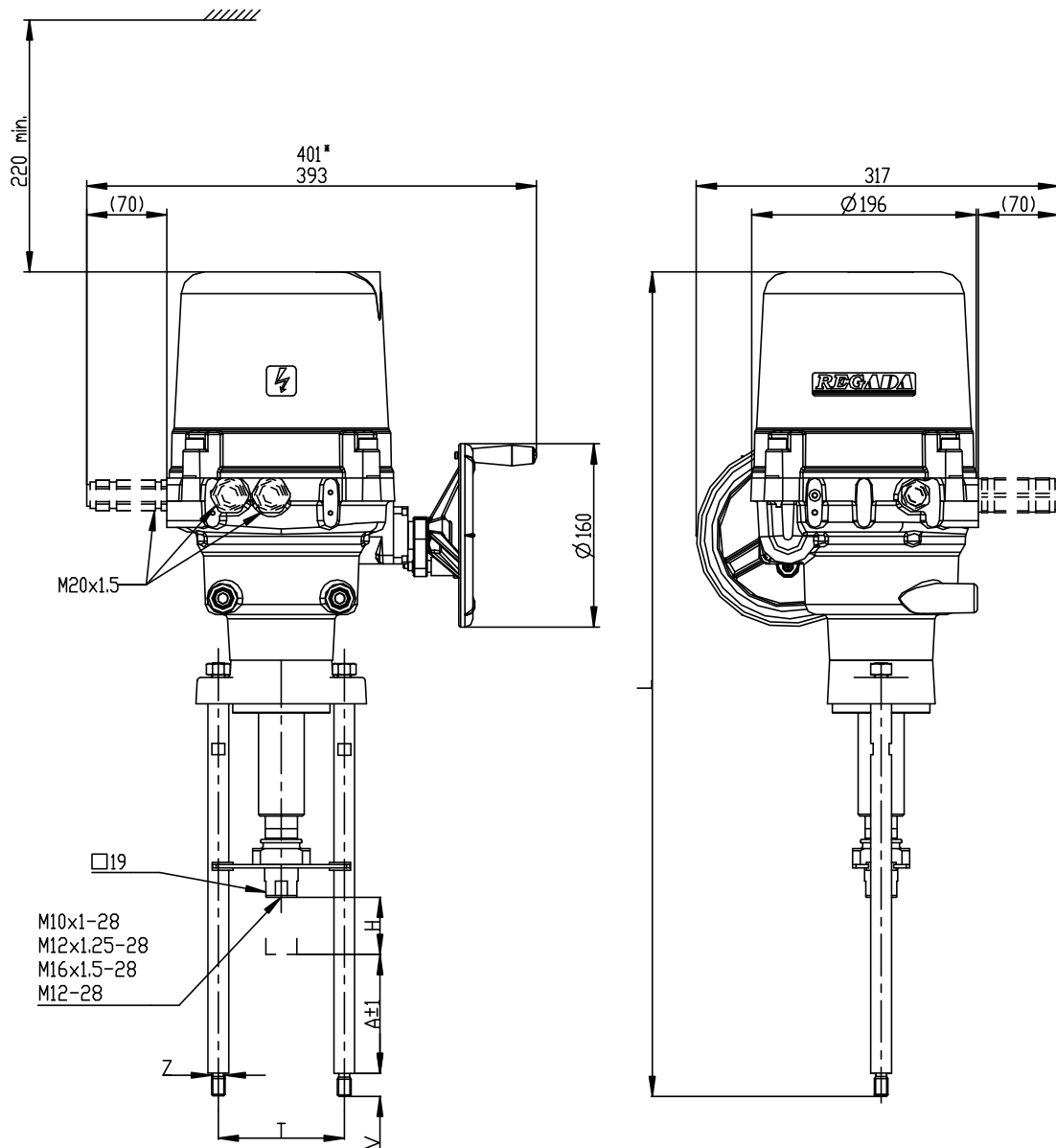

110	MAX. 50 (80)	100	M16	16	726
57		100	M16	16	673
27		100	M16	16	643
80		110	M12	32	696
42		110	M12	20	658
127		110	M12	20	743
A	H	T	Z	V	L

* - PLATI PRE VYHOTOVENIE S MIESTNYM OVLADANIM
 /* - VALID FOR VERSION WITH CONNECTOR/

P-2055

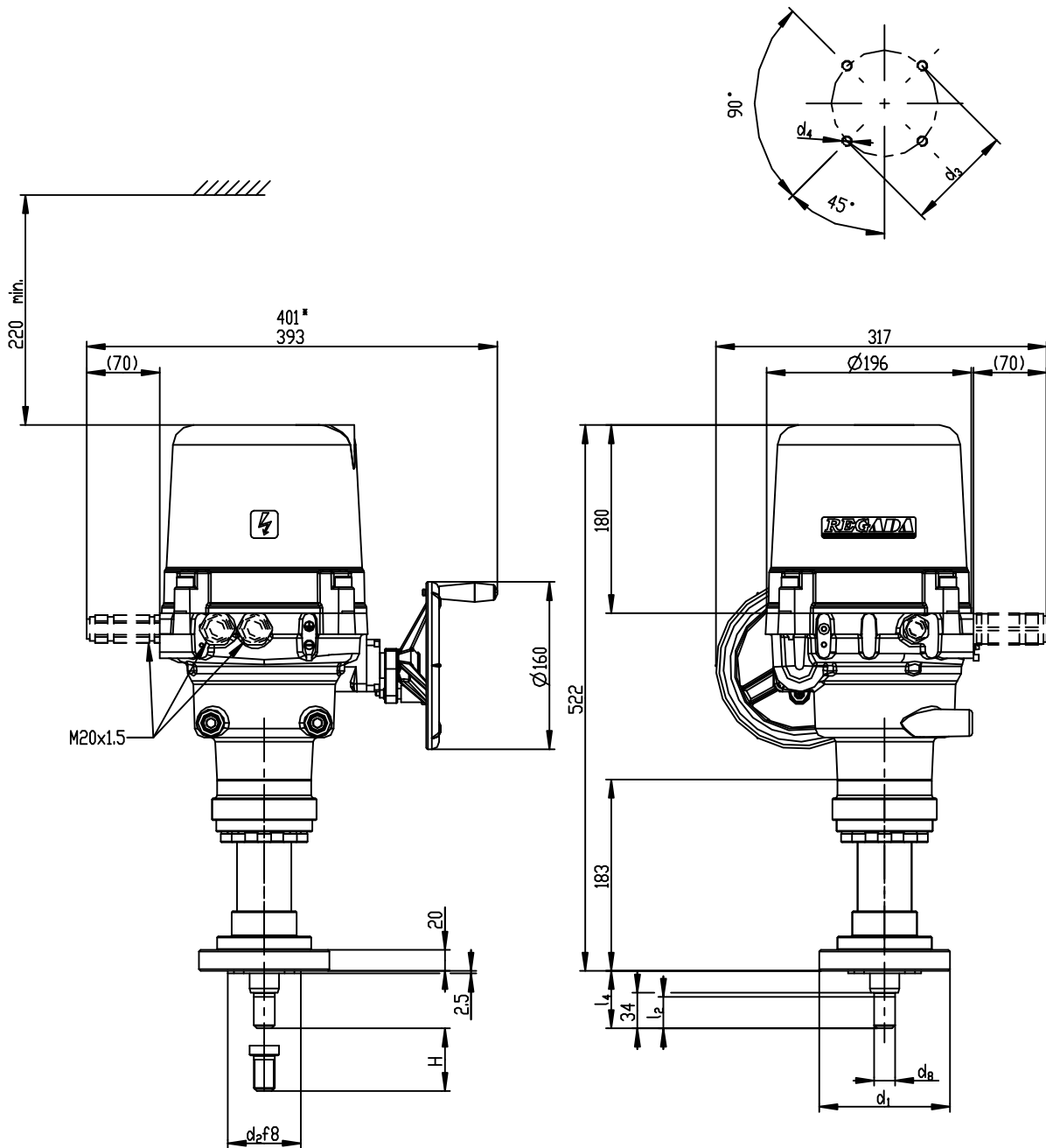

P-2055/B	F10	125	70	102	M10	30	55	M20x1.5	60
P-2055/A	F07	90	55	70	M8	25	50	M15x1.5	40
VYHOTOVENIE	PRIRUBA /FLANGE/	d_1	d_2	d_3	d_4	l_2	l_4	d_8	H

* - PLATI PRE VYHOTOVENIE S MIESTNYM OVLADANIM
 /* - VALID FOR VERSION WITH CONNECTOR/

Electric linear actuators **UL 2**

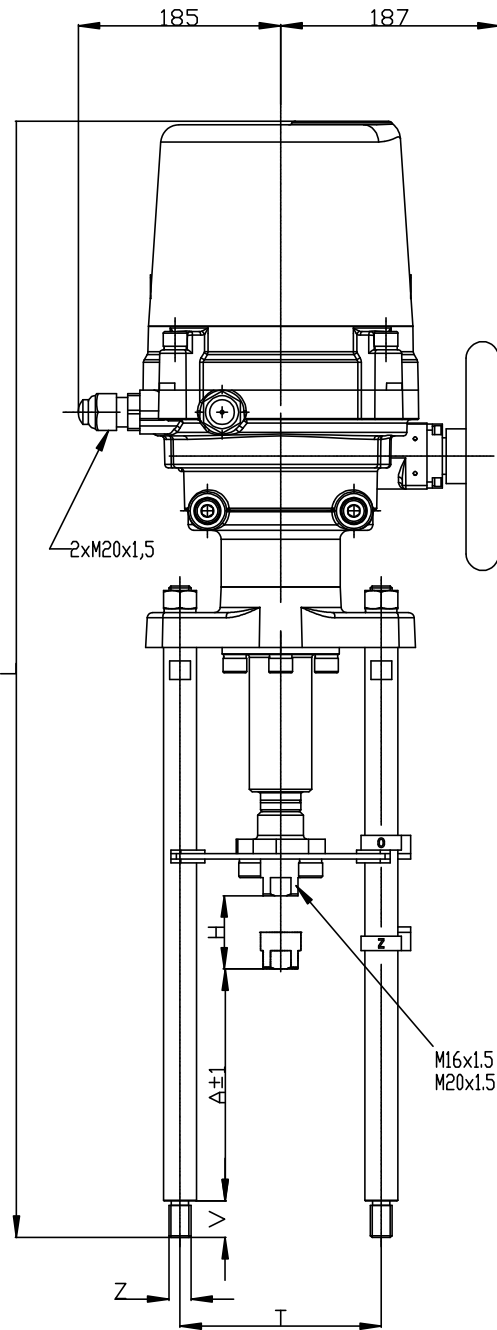
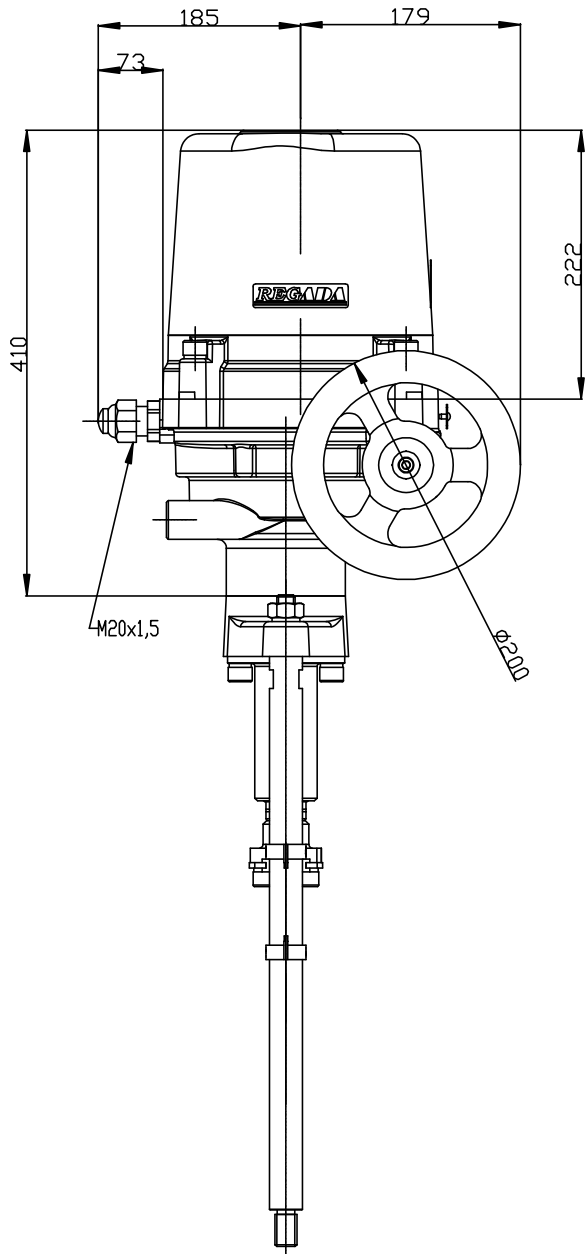

126					797
74	MAX. 80	150	M20	25	745
30					701
92			M16	40	778
A	H	T	Z	V	L

P-2144

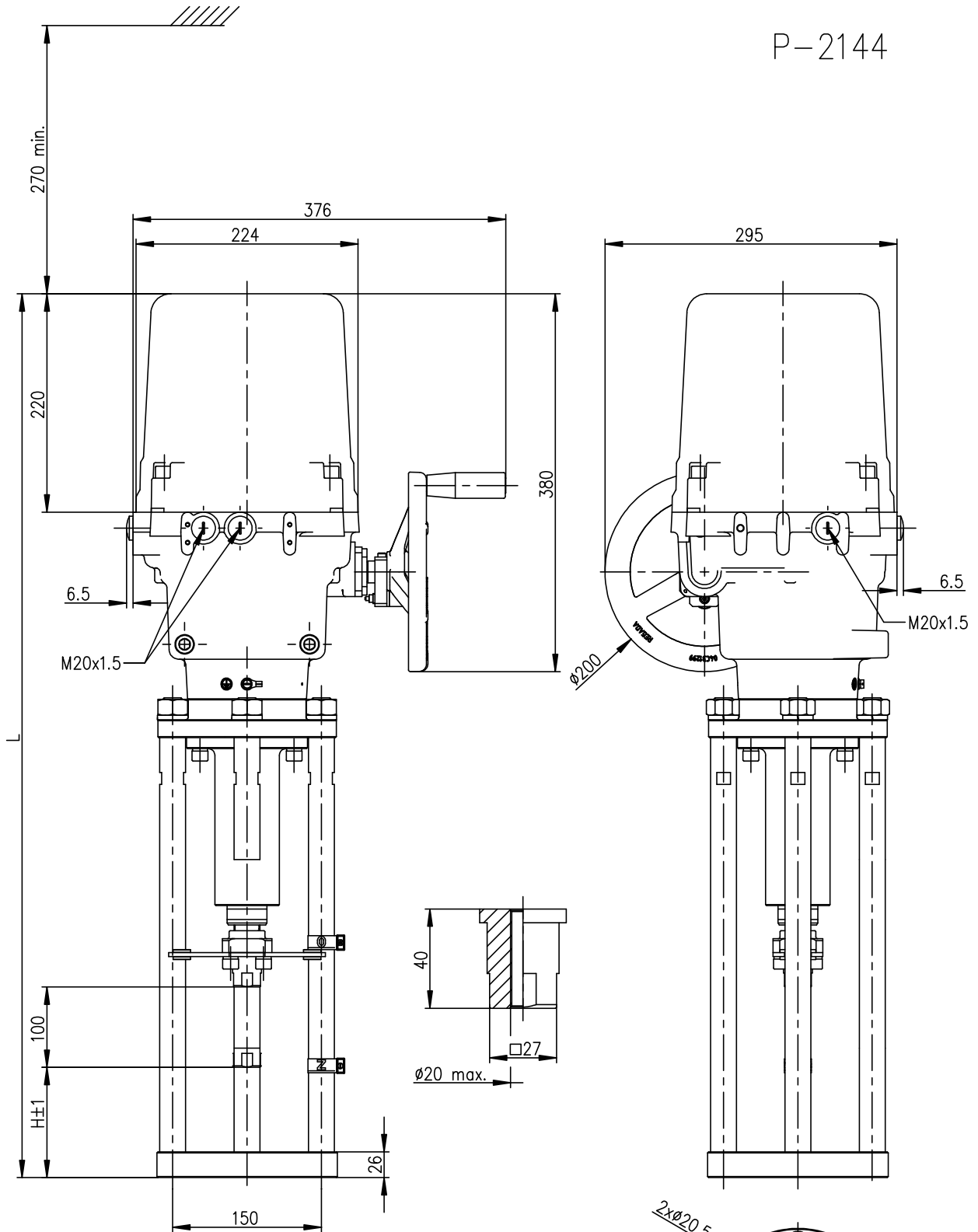

P-2144/D	126	924
P-2144/C	74	872
P-2144/B	30	828
P-2144/A	92	890
	H	L

P-2146

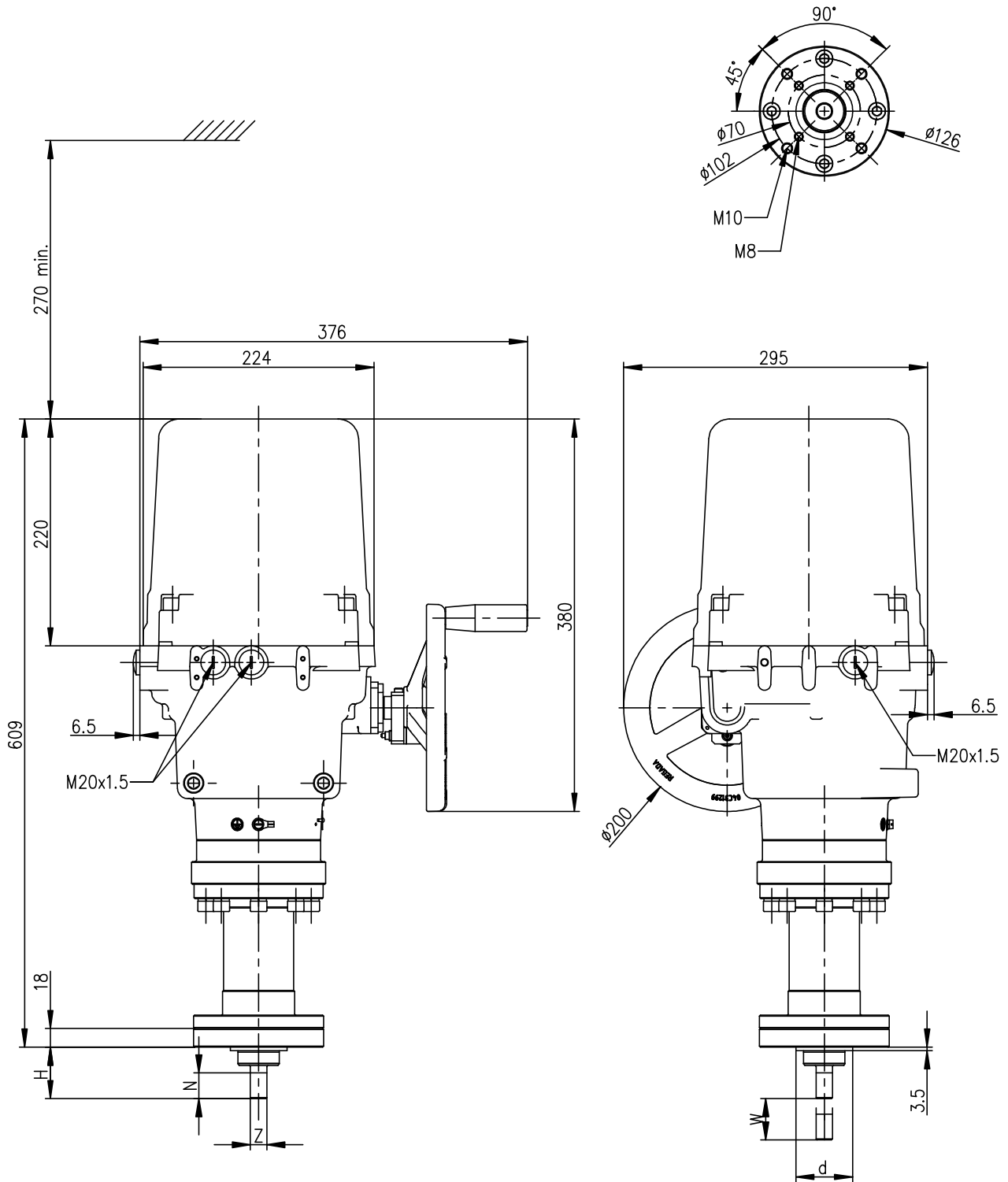

P-2146/B	ø70	55	30	60	M20x1.5
P-2146/A	ø55	50	25	40	M16x1.5
	d	H	N	W	Z

P-2147

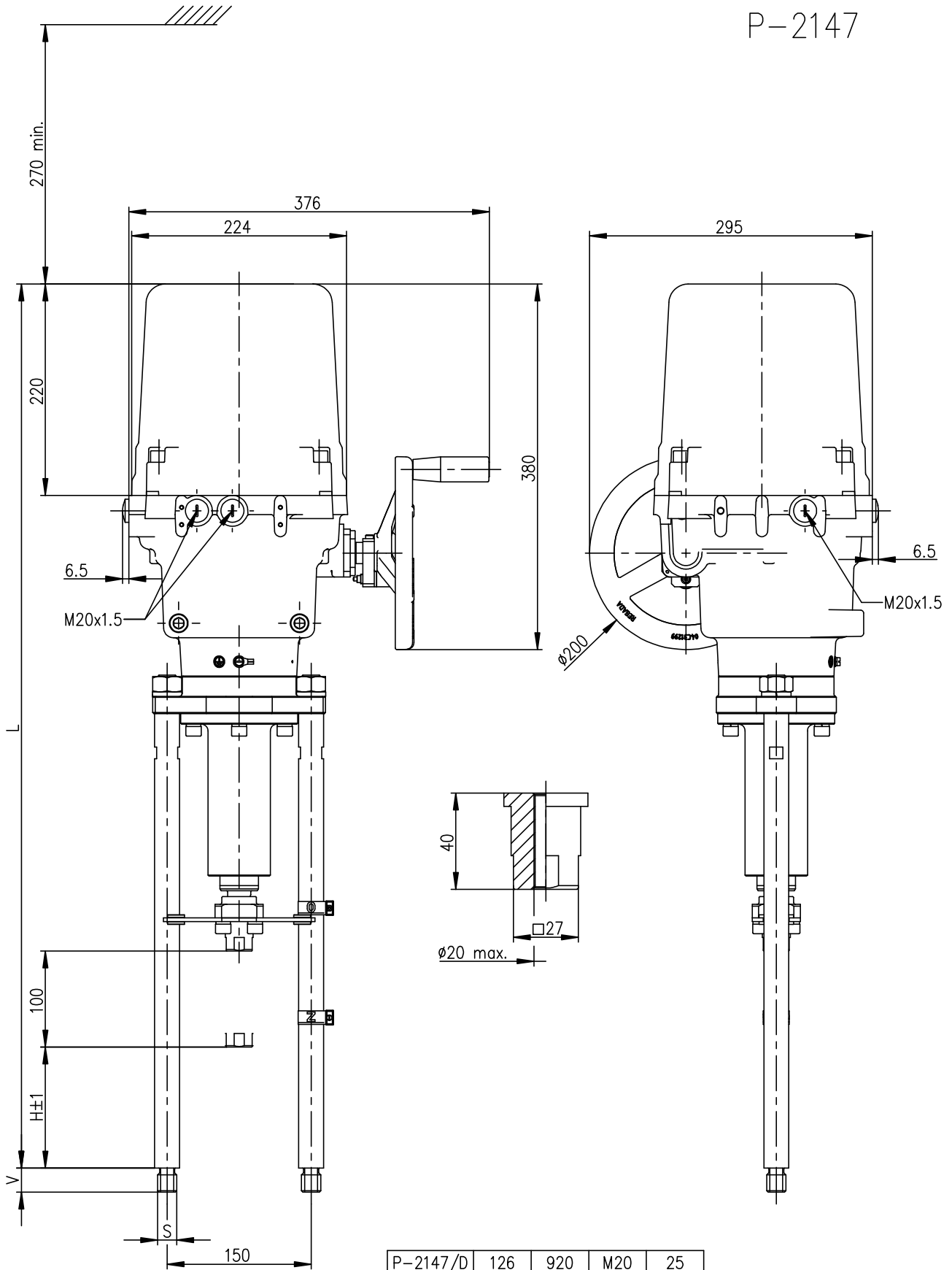

P-2147/D	126	920	M20	25
P-2147/C	74	868	M20	25
P-2147/B	30	824	M20	25
P-2147/A	92	886	M16	40
	H	L	S	V

7.5 Guarantee service check report

Service center:	
Date of repair:	Guarantee repair no.:
User of actuator:	Claim applied by:
Actuator type number:	Actuator production number:
Product claim fault:	Detected product fault:
Used spare parts:	
Remarks:	
Issued on a day:	Signature:

7.6 Post guarantee service check report

Service center:	
Date of repair:	
User of actuator:	Actuator operating place :
Actuator type number:	Actuator production number:
Detected product fault:	
Used spare parts:	
Remarks:	
Issued on a day:	Signature:

7.7 Commercial representation

Slovak Republic:

Regada, s.r.o.,
Strojnícka 7,
080 01 Prešov
Tel.: +421 (0)51 7480 460,
Fax: +421 (0)51 7732 096,
E-mail: regada@regada.sk