



CE

# ***INSTALLATION, SERVICE AND MAINTENANCE INSTRUCTIONS***



***Electric Part-Turn Actuators  
SP 1, SP 2, SP 2.3, SP 2.4  
SPR 1, SPR 2, SPR 2.3, SPR 2.4***

## TEST CERTIFICATE

ELECTRIC PART-TURN ACTUATOR SP .....		SPR .....
Type number .....	Power supply .....	V ..... Hz
Serial number .....	Max. load torque .....	Nm
Production year .....	Switching-off torque .....	Nm
Wiring diagram .....	Operating time .....	s/90°
.....	Operating angle .....	°
.....	Transmitter .....	
Warranty period .....	months	Input operating signal .....
Serial number of electric motor .....		
Serial number of transmitter .....		
Serial number of position controller .....		
Tests made in accordance with TP 74 0888 00		
Tests made by .....		Packed by .....
Date .....		Signature and stamp .....

## COMPLETENESS CERTIFICATE

Used valve .....	
Assembled by: Firm .....	
Name .....	
Warranty period .....	months
Date .....	Signature and stamp .....

## INSTALLATION CERTIFICATE

Location .....	
Installed by: Firm .....	
Name .....	
Warranty period .....	months
Date .....	Signature and stamp .....

Please read these instructions carefully before mounting and operating the actuator!

## Contents

1. General data.....	2
1.1 Purpose and applications.....	2
1.2 Safety instructions.....	2
1.3 Instructions for stuff training.....	2
1.4 Warning for safety use.....	3
1.5 Data specified on electric actuator.....	3
1.6 Warranty conditions.....	3
1.7 Under-guarantee and after-guarantee service.....	4
1.7.1 Lifetime of actuators.....	4
1.8 Operation conditions.....	4
1.8.1 Product location and operation position.....	4
1.8.2 Operation Environment.....	5
1.8.3 Power supply and duty cycle.....	6
1.9 Conservation, packing, transport, storing and unpacking.....	6
1.10 Assessment of the product and packaging and removal of contamination.....	7
2. Description, function and technical parameters.....	7
2.1 Description and function.....	7
2.2 Basic specifications.....	8
2.2.1 Mechanical connection.....	12
2.2.2 Electric connection.....	12
3. Installation and dismantling of actuator.....	13
3.1 Installation.....	13
3.1.1 Mechanical connection.....	13
3.1.2 Electric connection and checking of function.....	14
3.2 Dismantling.....	15
4. Adjusting of actuator.....	16
4.1 Adjustment of torque unit.....	16
4.2 Adjustment of position-indicating unit (Fig.4).....	16
4.3 Adjustment of resistant transmitter (Fig.5).....	17
4.4 Adjustment of the Electronic Position Transmitter (EPV) - the Resistive Transmitter (Potentiometer) with the Converter PTK 1.....	18
4.4.1 EPV – the 2-wire version (Fig. 6,6a).....	18
4.4.2 EPV – 3-wire version (Fig. 7,7a).....	19
4.5 Adjustment of Capacitive Transmitter CPT1/A.....	20
4.6 Resetting of operation angle and setting of stop end screws (Fig.9).....	21
4.6.1 Setting of stop end screws at position-unit switching-off.....	21
4.6.2 Setting of stop end screws at torque switching-off (Fig.9).....	21
4.7 Adjustment of position controller (Fig. 10).....	22
4.7.1 Setting of controller.....	22
4.7.2 Watching operation and error states.....	23
5. Service, maintenance and troubleshooting.....	25
5.1 Service.....	25
5.2 Maintenance - extent and periodicity.....	26
5.3 Troubleshooting.....	27
6. Accessories and spare parts.....	27
6.1 Accessories.....	27
6.2 Spare part list.....	27
7. Enclosures.....	28
7.1 Wiring diagrams.....	28
7.2 Dimensional drawings.....	38

The Installation, Service and Maintenance Instructions are drawn up according to requirements of EC Executive Nr. 2006/42/EC "Uniform requirements for machines and devices from the point of view of safety and health care", to save life and health of users and to avoid material damages and exposure environment to danger.

## 1. General data

### 1.1 Purpose and applications

Electric part-turn actuators (hereinafter **EA**) of **SP 1, SP 2, SP 2.3, SP 2.4** (hereinafter **SP**) or **SPR 1, SPR 2, SPR 2.3, SPR 2.4** (hereinafter **SPR**) types are high-powered electric-mechanical products designed for direct installations onto controlled devices (regulating bodies - valves, etc.). EA of SP types are provided for remote control of closing bodies, and EA of SPR types for automotive control of regulating bodies in both directions of their movement. They can be equipped with means of measuring and control of technological processes where an unified analogue direct current or voltage signal is an information bearer on their input and/or output. They can be used in heating, energy, gas, air-conditioning and other technological systems, which they are suitable for, regarding their features. They are connected with controlled devices with a flange according to ISO 5211 and a coupling or using a stand and a coupling/a lever.

#### Notes:



1. Do not count with tight closing performed by control signals of EA SPR.
2. It is forbidden to use EA as a lifting mechanism!
3. Switching of actuator by a semiconductor switches have to be consulted with producer.

### 1.2 Safety instructions



EA are reserved technical devices with higher rate of danger, with possibility of installation in areas specially danger regarding casualties caused by electric current.

Electric actuators are according to directive LVD 2014/35/EU and standard EN 61010-1+A1, in the edition in terms of valid certificate, assigned for installation category II (overvoltage category), pollution degree 2.

The product meets the essential safety requirements according to EN 60204-1 and is in compliance with EN 55011/A1 within valid edition.

#### **Product influence to environment**

**Electromagnetic compatibility (EMC):** the product complies with the requirements of the Directive 2014/30/EU of the European Parliament and of the Council on the approximation of the laws the Member States relating to the electromagnetic compatibility and with the requirements of standards as well EN IEC 61000-6-4, EN IEC 61000-6-2, EN IEC 61000-3-2 and EN 61000-3-3+A1, in the edition in terms of valid certificate.

**Vibrations caused by the product:** product influence is negligible

**Noise produced by the product:** The maximum allowable noise level (A) of the product measured in a place of operation is 78 dB (A).

### 1.3 Instructions for staff training

#### **Requirements for professional qualification of people performing installation, service and maintenance**



The electrical connection of the actuator can only be carried out by a person in accordance with legislative requirements of the given country, depending on the required areas of location/use. Service can be performed only by workers professionally qualified and trained by the producer or contracted service centre.

### 1.4 Warning for safety use



1. Products are assigned for operation in environment consist of gas, steam and vapours, with temperature range:  $-25^{\circ}\text{C}$  to  $+55^{\circ}\text{C}$  or  $-50^{\circ}\text{C}$  to  $+40^{\circ}\text{C}$  or  $-60^{\circ}\text{C}$  to  $+40^{\circ}\text{C}$ , with pressure range from 0.8 to 1.1 bar.
2. If the actuator is placed on device which regulate medium with higher temperature than  $+55^{\circ}\text{C}$ , protect the actuator by additional construction in order to maintain ambient temperature max.  $+55^{\circ}\text{C}$  and also to stop temperature transmitting through junction component!
3. Cable glands blinds are assigned only for transport and storage period, i.e. for period till the actuator is builded into operation, than blinds must be replace by connecting cable.
4. In case of not using one of the cable gland, it has to be replaced with a suitable blinding plug.
5. Temperature at the point where the cables enter the actuator can reach max.  $90^{\circ}\text{C}$ . When choosing the connection cables for the actuator, it is therefore necessary to consider this temperature as well.

#### Product protection

EA **SPR1-SPR2.4** does not have own short-circuit protection, therefore there must be included suitable protective device into the supply power ( circuit breaker, or fuse), which serves at the same time as main switch. For protection, we recommend to use a fuse type "T" or a contactor type "C".

**Type of equipment from a connection point of view:** The equipment is designed for permanent connection.

### 1.5 Data specified on electric actuator

Nameplate:

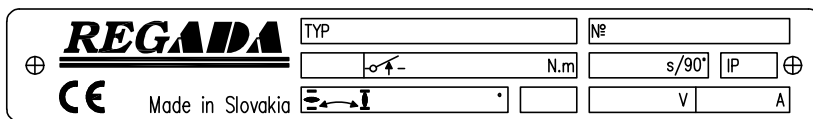

Warning plate:



Nameplate contains the basic data concerning identification, performance and electricity: indication of producer, type, serial number, max. load torque and switching-off torque, operating time, protection code, operating angle, supply voltage and current.

#### Graphic symbols on electric actuator

The graphic symbols used on electric actuator substitute the text messages. Some of them are in accordance with ISO 7000 and IEC 60417 within valid edition..



Dangerous voltage

(5036 IEC 60417)



Stroke of the electric part-turn actuator



Switching-off torque



Manual control

(0096 ISO 7000)



Protection terminal

(5019 IEC 60417)

### 1.6 Warranty conditions

The supplier is responsible for completeness of the delivery and guarantees these specifications of the product which are stated in Technical conditions (TP) or specifications agreed in the Contract.

The supplier is not responsible for any deterioration of parameters caused by the customer during storage, unauthorised installation or improper operation.

## 1.7 Under-guarantee and after-guarantee service

Our customers are provided with professional service of our firm in installation, operation, service, maintenance, revision and help in troubleshooting for all our products.

**Under-guarantee service** is performed by the service department of the production plant, or by a contracted service centre according to a written claim.

In case of occurring of any fault please let us know it and state:

- type code
- serial number
- ambient parameters (temperature, humidity...)
- duty cycle including frequency of switching
- type of switching-off (position or torque)
- set switching-off torque
- type of fault - description of claimed fault
- it is recommended to place also Installation certificate.

It is recommended to have after-guarantee service performed by the service department of the production plant, or by a contracted service centre.

### 1.7.1 Lifetime of actuators

The lifetime of an electric actuator (EA) is at least 6 years.

EA used for closing mode (closing valves) comply with the requirements for at least **15,000 working cycles** (cycle C – O – C: for part-turn EA)

EA used for regulating/modulating operation (control valves) comply with the below stated numbers of **operating hours** at the total number of 1 million start-ups:

Switching frequency				
max. 1,200 [h <sup>-1</sup> ]	1,000 [h <sup>-1</sup> ]	500 [h <sup>-1</sup> ]	250 [h <sup>-1</sup> ]	125 [h <sup>-1</sup> ]
Minimal lifetime expectancy – number of operating hours				
850	1,000	2,000	4,000	8,000

Time of **net operation** is min. 200 hours, max. 2,000 hours.

**Lifetime at operating hours** depends on loading and switching frequency.

Note : High switching frequency does not ensure better regulation. Setting of regulation parameters should be therefore made with the inevitably necessary switching frequency needed for the process in question.

## 1.8 Operation conditions

### 1.8.1 Product location and operation position



Electric actuators may be installed and operated in enclosed locations of industrial facilities with no temperature and moisture regulation, protected from direct climatic effects (such as direct sunlight). Moreover, special “marine” versions may be used in waste water treatment applications, water management, selected chemical applications, tropical environments and coastal areas.

Installation and operation of EA is possible in **any position**. Vertical position of output part axis and with the control part above the valve is usual.

#### Warning:



When the EA is installed in open air, **it must be** sheltered lightly to protect is against direct effects of atmosphere.

When installed in the areas with relative humidity more than 80%, in open air under a shelter is needed to connect the space heater directly – without a thermal switch.

## 1.8.2 Operation Environment

According to valid standard IEC 60 721-2-1, there are delivered these versions of electric actuators:

- 1) Version „standard“ for type climate temperate
- 2) Version „tropical wet“ for type climate tropical wet
- 3) Version „cold“ - for type climate cold
- 4) Version „tropical dry and dry“ for type climate tropical dry and dry
- 5) Version „marine“ for type climate marine
- 6) Version „arctic“ for type climate arctic.

In accordance with IEC 60 364-1, IEC 60 364-5-51 within valid edition the EA have to resist external effects and operate reliably:

In the conditions of the following types of environment:

- warm mild to very hot dry with temperature in range -25°C to +55°C .....AA 7\*
- cold to warm mild and dry with temperatures in range -50°C to +40°C .....AA 8\*
- cold to mild hot dry with temperatures in range -60°C až +40°C ..... AA 1\*+AA 5\*
- with relative humidity 10 to 100 %, including the condensation of up to 0,029 kg water content per 1 kg of dry air, at above stated temperature .....AB 7\*
- with relative humidity of 15÷100%, including the condensation of up to 0,036 kg water content per 1 kg of dry air, at above stated temperature .....AB 8\*
- with relative humidity 5 to 100 %, including the condensation of up to 0,025 kg water content per 1 kg of dry, at above stated temperature ..... AB 1\*+AB 5\*
- with height above sea level 2 000 m, with barometric pressure range 86 to 108 kPa .....AC 1\*
- with spraying or jet water from all directions–(protection enclosure IP x5) .....AD 5\*
- with shallow dive – (product in protection IP x 7) .....AD 7\*
- with submersion – (product with enclosure IPx8).....AD 8\*
- with strong dustiness – with a possibility of influences of inflammable, non-conducted and non-explosive dust; the middle layer of dust; the dust drop more than 350 but not more than 1000 mg/m<sup>2</sup> per day (products with protection enclosure of IP 6x) ..... AE 6\*
- with atmospheric occurrence of corrosive and pollution media (with high degree of atmosphere corrosive aggressiveness); important presence of corrosive pollution ..... AF 2\*
- with permanent exposure of big amount of corroding or contaminated chemicals and salt fog in execution for sea environment , for sewage water disposal plant and some chemical plant....AF 4\*
- with a possibility of influences of mechanical stress:
  - medium sinusoid vibrations with frequency in range 10 up to 150 Hz, with shift amplitude of 0,15 mm for  $f < f_p$  and acceleration amplitude 19,6 m/s<sup>2</sup> for  $f > f_p$ ; (transition frequency  $f_p$  is from 57 up to 62 Hz) .....AH 2\*
  - medium impacts, shocks and vibrations ..... AG 2\*
- with serious danger of plants and moulds growing ..... AK 2\*
- with serious danger of animals occurrence (insects, birds, small animals) .....AL 2\*
- with detrimental influence of radiation:
  - of stray current with intensity of magnetic field (direct and alternating of power supply frequency) to 400 A.m<sup>-1</sup> .....AM 2-2\*
  - of sun radiation with intensity  $> 500$  a  $\leq 700$  W/m<sup>2</sup> ..... AN 2\*
- with effects of medium seismic activity with acceleration  $> 300$  Gal  $\leq 600$  Gal ..... AP 3\*
- with indirect danger of storm activity .....AQ 2\*
- with fast moving of air and strong winds ..... AR 3 , AS 3\*
- with persons frequent touching earth potential (persons often touch conductive parts or they stand on the conductive basement) ..... BC 3\*
- without any danger media with object ..... BE 1\*

\* Marking in accordance with IEC 60364-1, IEC 60 364-5-51 within valid edition

### 1.8.3 Power supply and duty cycle

#### Power supply:

electric motor.....	220/230 V AC, 3x380/3x400 V; 24 V AC / 24 V DC $\pm 10\%$ , 120 V AC $\pm 10\%$ (other - after agreement with manufacturer)
control .....	<b>230 V AC</b> , resp. <b>24 V AC <math>\pm 10\%</math></b>
potentiometer transmitter .....	$\sqrt{P \times R}$ V DC/AC)
electronic positional transmitter without power supply .....	15 up to 30 V DC, or 24 V DC
capacitive transmitter without power supply .....	18 up to 28 V DC

**Power supply frequency** ..... 50 Hz or 60 Hz  $\pm 2\%$

*Note:* At frequency of 60 Hz Operating times reduced by 1.2 times.

**Duty cycle** (according to EN (IEC) 60034-1 within valid edition):

**EA SP** are designed for **remote control**:

- short-time operation **S2-10 min**
- intermitted operation **S4-25%, 6 up to 90 cycles per hour.**

**EA SPR** are designed for **automatic regulation**:

- intermitted operation **S4-25%, 90 up to 1200 cycles per hour**

#### Notes:

1. The operation modes consist of the loading type, load factor and connection/switching frequency.
2. EA SP is possible connect with external regulator and use it as regulated EA and for this EA stand duty cycle and power parameters like for type SPR with built-in regulator. For cooperation with controllers we do not recommend operating times 5 and 10 s/90°.

### 1.9 Conservation, packing, transport, storing and unpacking

Surfaces without surface treatment are treated by conservation preparation MOGUL LV 2-3 before packaging .

Conservation is not necessary if the following storage conditions are complied with:

- Storage temperature: -10 to +50 °C
- Relative air humidity max.80 %
- Electric actuators and their accessories must be stored in dry, well ventilated covered spaces, protected against impurities, dust, soil humidity (by placement to racks, or on palletes), chemicals and foreign interventions
- There shall be no corrosive gases present in the storage areas.

The EA SP or SPR are delivered in solid packages guaranteeing resistance in accordance with EN 60 654 (IEC 60 654-1 and IEC 60 654-3).

Package is a box. Products in boxes is possible to load on the pallets (pallet is returnable). On the outer side of the package is stated:

- manufacturer label,
- name and type of product,
- number of pieces,
- other data – notices and stickers.

The forwarder is obliged to secure packed products, loaded on transportation means, against self-motion; if open transportation means are used, to secure their protection against atmospheric precipitations and splashing water. Displacement and securing of products in transportation means must provide their stable position, exclude the possibility of their inter-collision and their collision with the vehicle walls.

Transportation and storing can be executed by heatless and non hermetic spaces of transportation vehicles with influences within the range:

- temperature: -25° C up to +70° C (a strange version – 45 ° C up to + 45 ° C)
- humidity : 5 up to 100 %, with max. water content 0.028 kg/kg of dry air
- barometric pressure 86 up to 108 kPa.

**Upon receiving of EA examine, if during transportation, resp. storing did not come to its damage. At the same time verify, if the data on the labels corresponds to accompanying**



**documentation and purchase-sale contract / order. Eventual discrepancies, faults and damages should be reported without any delay to supplier.**



Electric actuators and their accessories must be stored in dry, well ventilated covered spaces, protected against impurities, dust, soil humidity (by placement to racks, or on palettes), chemicals and foreign interventions, at ambient temperature from -10°C up to +50°C and at relative air humidity max. 80 %.

***It is not acceptable to store EA outdoors, or in areas not protected against direct climate influence!***

Eventual damages to surface finish remove without delay – thus preventing damage by corrosion.

If storing takes longer than 1 year, it is necessary to inspect lubrication fillings before putting EA into operation.

Assembled EA, but not put into operation is necessary to protect by the equivalent method as during storage (for example suitable protective cover).

After assembly to the armature in free and wet areas, or in areas with temperature changes, connect without delay heating resistor – thus preventing damages caused by corrosion from liquefied water in the control area.

Excessive preserving grease remove just before putting EA into operation.

### **1.10 Assessment of the product and packaging and removal of contamination**

The product and its package are made of recycling materials. Do not throw the single parts of the package and of the product after their life but sort them according to instructions in corresponding executives or regulations of environment protection, and allow their recycling.

The product and its packing are not a source of any environment pollution or contamination and do not contain any dangerous waste.

## **2. Description, function and technical parameters**

### **2.1 Description and function**

The **SP and SPR EA** consist of two parts differing in their function.

The **gear part** is made up by a flange and a connected part for connection onto a controlled device, and gears placed in the bottom; on the other side drive mechanisms for control part units are surfaced.

The **control part (Fig. 3)** is placed on a control board (2) consisting of:

- an electric motor (at single-phase version with capacitor)
- a torque unit (controlled with a worm axial shift)
- a position-signaling unit with (3) a position transmitter (5) - positioner (resistive - potentiometer, capacitive or an electronic position transmitter) and with a mechanical local position indicator
- a space heater with a thermal switch (8)
- electric connection is realised using **terminal boards** (6) (located in the control area) and cable cable glands (12) , or **connector** with cable cable glands.

#### **Additional accessories:**

**Manual control:** made up by a handwheel with a worm gearing.

**Local electric control module** (Fig.11).

The **SPR** version is equipped with an **electronic controller**. The position controller allows automatic position adjustment of the EA output part depending upon the input signal value and provides also additional functions.

## 2.2 Basic specifications

### Basic EA specifications:

Switching-off torque [Nm], Operating time[s/90°], Operating angle [°], and electric motor parameters are given in Table 1.

Table 1: Basic Specifications

Type Number	Operating time $\pm 10$ [%]	Operating angle	Switching-off torque $\pm 10$ [%]	Weight	Electric motor <sup>1)</sup>						
					Power supply nominal voltage	Nominal			Capacitor capacity		
						power	speed	current			
	[s/90°]	[°]	[Nm]	[kg]		[V/Hz]	[W]	[1/min]	[A]	[ $\mu$ F/V]	
1	2		6	7	8	9	10	11	12	13	
SP 1/SPR 1 Type Nr. 281	10	60°, 90°, 120°, 160°, without stop ends 360°, without stop ends and without transmitter >0°, <360°	46	6,0 – 8,0	Single-phase	220/50 230/50 (120/60)	15	2750	0,18	2,2/400	
	20		(18)				(3350)	(0,44)	(6/250)		
	40										
	80		4				1270	0,14	2,2/400		
	10				46	Single-phase/ direct current- voltage	24 AC/50 24 V DC	32	3000	3,1/ 1,9	-
	20		90								
	40										
	10				46	Three-phase	3x380/50 3x400/50	15	2680	0,10	-
	20		90								
	40										

Type Number	Operating time $\pm 10\%$	Operating angle	Switching-off torque $\pm 10$ [%]	Weight	Electric motor <sup>1)</sup>					
					Power supply nominal voltage	Nominal			Capacitor capacity	
						power	speed	current		
	[s/90°]	[°]	[Nm]	[kg]		[V]	[W]	[1/min]	[A]	[ $\mu$ F/V]
1	2	3	6	7	8	9	10	11	12	13
SP 2/SPR 2 Type Nr. 282	5	60°, 90°, 120°, 160°, without stop ends 360°, without stop ends and without transmitter >0°, <360°	72	11,5 – 16,5	Single-phase	220/ 230	60	2750	0,70	7/400
	10		20				1350	0,50		
	20									
	40									
	80		145		Single-phase/ direct current- voltage	24 AC/ DC	93	3100	6,2/ 5,0	-
	5		72							
	10		145							
	20									
	40									
	5		72		Three-phase	3x380/ 3x400	90	2740	0,35	-
	10		145							
	20									
40										
SP 2.3/SPR 2.3 Type Nr. 283	20	60°, 90°, 120°, 160°, without stop ends 360°, without stop ends and without transmitter >0°, <360°	290	17,0 – 35,0	Single-phase	220/ 230	60	2750	0,70	7/400
	40						20	1350	0,50	
	80									
	160									
	20		290		Single-phase/ direct current- voltage	24 AC/ DC	93	3100	6,2/ 5,0	-
	40									
	80									
	20									
	40		290		Three-phase	3x380/ 3x400	90	2740	0,35	-
	80									
	20									
	40									
SP 2.4/SPR 2.4 Type Nr. 284	40	60°, 90°, 120°, 160°, without stop ends 360°, without stop ends and without transmitter >0°, <360°	575	20,5 – 55,5	Single-phase	220/ 230	60	2750	0,70	7/400
	80						20	1350	0,50	
	160									
	40						575	Single-phase/ direct current- voltage	24 AC/ DC	
	80									
	40									
	80									
	40		575		Three-phase	3x380/ 3x400	90	2740	0,35	-
	80									
	40									
	80									

1) Switching elements for different type of load (also for EA) defines standard EN (IEC) 60 947-4-1.

**Other specifications:****EA protection enclosure:** ..... IP 67, IP 68 ((EN (IEC) 60 529 within valid edition))

According to definition for EA, enclosure IP68 fulfills following requirements:

-water column max. 10m

-time of continuous submersion in water max. 96 hours.

**Mechanical ruggedness:**

sinusoid vibrations .....with frequency in range from 10 up to 150 Hz,  
 with shift amplitude of 0.15 mm for  $f < f_p$   
 with acceleration amplitude of  $19.6 \text{ m/s}^2$  for  $f > f_p$   
 (transition frequency  $f_p$  is from 57 up to 62 Hz)

**Self-locking:** ..... with mechanical or electric-mechanical brake**Electric motor protection:** ..... with thermal switch**EA braking:** ..... SP 1/SPR1 with mechanical brake

..... SP/SPR 2, 2.3, 2.4 with electric-magnetic brake

**Output part backlash:**..... < 1.5° for SP

..... &lt; 1° for SPR, at load of 5% of load torque

**Switching-off:**

Switching-off voltage ..... max. 250V, 50/60 Hz, 2A or 250V DC; 0.1A

Hysteresis of position switches ..... max. 3%

Switching-off torque is adjusted to maximum value with tolerance  $\pm 10\%$ , if not agreed else.

Operation angle is adjusted at producer according to specified value.

**Space heater (E1)**

Space heater - supply voltage: ..... corresponding with motor supply voltage (max. 250 V AC)

Space heater power output: SP/SPR 1 ..... max. 10 W/55°C

SP/SPR 2, 2.3, 2.4 ..... max. 20 W/55°C

**Thermal switch of space heater (F2)**

Supply voltage: ..... corresponding with motor supply voltage (max. 250V AC)

Switching-on temperature:.....  $+20^\circ\text{C} \pm 3^\circ\text{C}$ Switching-off temperature:.....  $+30^\circ\text{C} \pm 4^\circ\text{C}$ **Position transmitter****Resistive – potentiometer:**Resistance (single **B1**):..... 100  $\Omega$ , 2000  $\Omega$ Resistance (double **B2**): ..... 2x100  $\Omega$ , 2x2000  $\Omega$ Operating life of transmitter .....  $1.10^6$  cyclesLoad capacity:..... 0,5 W do  $40^\circ\text{C}$ , (0 W/ $125^\circ\text{C}$ )

Maximum current of sliding contact ..... max.35 mA

Maximum supply voltage: .....  $\sqrt{P \times R}$  V DC/ACPotentiometer linearity error: .....  $\pm 1.5 [\%]^{1)}$ Potentiometer hysteresis: ..... max.  $1.5 [\%]^{1)}$ For SP: "O" (open) .....  $\geq 93\%$ , "Z" (closed) .....  $\leq 5\%$ For SPR: "O" (open).....  $\geq 85\%$  and  $\leq 95\%$ , "Z" (closed)  $\geq 3\%$  and  $\leq 7\%$ **Capacitive (B3): non-contact, life  $10^8$  cycles****2-wire connection** with power supply or without power supply

The current signal **4** , **20 mA** (DC) is acquired from the capacitive transmitter supplied from the internal or an external voltage supply source. The electronics of the transmitter is protected against eventual wrong polarity and current overloading. The entire transmitter is galvanic insulated so several transmitters can be connected to one external voltage source.

Power supply voltage (with power supply) ..... 24 V DC

Power supply voltage (without power supply) ..... 18 to 28 V DC

Ripple voltage ..... max. 5%

Max power input..... 0,6 W

Load resistance..... 0 to 500  $\Omega$ 

Load resistance can be single side grounded.

Influence of resistance on output current ..... 0,02%/100  $\Omega$ 

Influence of voltage on output current ..... 0,02%/1V

Temperature dependency..... 0.5% /  $10^\circ\text{C}$ 

Output signal values at limit positions: ..... "O" .... 20 mA (terminals 81,82)

..... "Z" ..... 4 mA (terminals 81,82)

Values tolerance of output signal of capacitive transmitter ..... "Z"  $+0,2 \text{ mA}$ ..... "O"  $\pm 0,1 \text{ mA}$

Capacitive transmitter linearity error .....  $\pm 1,5[\%]$ <sup>1)</sup>  
 Capacitive transmitter hysteresis ..... max.  $1,5 [\%]$ <sup>1)</sup>

**Electronic positional transmitter (EPV) - converter R/I (B3)**

**a) 2-wire version - without built-in power supply, or with built-in power supply**

Current signal .....  $4 \div 20$  mA (DC)  
 Power supply voltage .....  $15 \div 30$  V DC  
 Power supply voltage (at version with build-in power supply) .....  $24$  V DC  $\pm 1,5\%$   
 Load resistance (at version without build-in power supply) ..... max.  $R_L = (U_n - 9V) / 0,02A$  [ $\Omega$ ]  
 (Un - power supply voltage [V])  
 Load resistance (at version with build-in power supply) ..... max.  $R_L = 750 \Omega$   
 Temperature dependency ..... max.  $0,020$  mA /  $10^\circ\text{C}$   
 Output signal values at limit positions: ..... "O" .....  $20$  mA (terminals 81,82)  
 ..... "Z" .....  $4$  mA (terminals 81,82)  
 Values tolerance of output signal of EPV ..... "Z" .....  $+0,2$  mA  
 ..... "O" .....  $\pm 0,1$  mA

**b) 3-wire version - without built-in power supply, or with built-in power supply**

Current signal .....  $0 \div 20$  mA (DC)  
 Current signal .....  $4 \div 20$  mA (DC)  
 Current signal .....  $0 \div 5$  mA (DC)  
 Power supply voltage (at version without built-in power supply) .....  $24$  V DC  $\pm 1,5\%$   
 Load resistance ..... max.  $3$  k $\Omega$   
 Temperature dependency ..... max.  $0,020$  mA /  $10^\circ\text{C}$   
 Output signal values at limit positions: ..... "O" .....  $20$  mA or  $5$  mA (terminals 81,82)  
 ..... "Z" .....  $0$  mA or  $4$  mA (terminals 81,82)  
 Values tolerance of output signal of EPV transmitter ..... "Z"  $+0,2$  mA  
 ..... "O"  $\pm 0,1$  mA  
 EPV linearity error: .....  $\pm 1,5 \%$ <sup>1)</sup>  
 EPV hysteresis: ..... max.  $1,5 \%$ <sup>1)</sup>

<sup>1)</sup> from rated value of transmitter referred to output values

**Electronic position controller (N)**

**Controller software equipment:**

**A) Function and parameters**

programmable **functions:**

- ...with functional buttons SW1, SW2 and LED diodes D3, D4 directly placed on controller
- ...with computer or terminal equipped with corresponding programme, using RS 232 interface.

programmable **parameters:**

- ...control signal
- ...response to SYS-TEST signal
- ...mirroring (ascending/descending characteristics)
- ...insensitiveness
- ...EA limit positions (only with computer and ZP2 programme)
- ...way of regulation

**B) Operation states of controller**

**Error message** from error memory: (using LED diodes and RS 232 and personal computer)

- ...control signal missing or faulty
- ... input value of current control signal under  $3.5$  mA
- ...existence of SYS-TEST signal
- ...activity of switches
- ...failure of feedback position transmitter

**Statistic data:** (using RS 232 and personal computer)

- ...number of controller operation hours
- ...frequency of relay switching in direction "opening"
- ...frequency of relay switching in direction "closing"

**Supply voltage:** ..... terminal 61 (L1) -1(N) -  $230$  V AC  $\pm 10\%$

**Frequency:** .....  $50/60$  Hz  $\pm 2\%$

<b>Input control signals - analogue:</b> .....	0 - 20 mA
.....	4 - 20 mA
.....	0 - 10 V
Input resistance for signal 0/4 - 20 mA .....	250 $\Omega$
Input resistance for signal 0/2 - 10 V .....	50k $\Omega$
(Actuator opens at rising of control signal.)	
<b>Controller linearity:</b> .....	0.5 %
<b>Controller insensitiveness:</b> .....	1 - 10% (adjustable)
<b>Feedback (position transmitter):</b> .....	resistive 100 up to 10,000 $\Omega$
.....	current 4 up to 20 mA
<b>Power outputs:</b> .....	2x relay 5A/250 V AC
<b>Digital outputs:</b> .....	4x LED (supply, error, adjustment, "opening", "closing" - with two-colour LED)
<b>Error status:</b> .....	control switch 24 V, 2W - POR
<b>Reaction at error situation:</b>	transmitter error - error message LED
<b>Control signal missing:</b> .....	error message LED
<b>SYS mode:</b> .....	error message LED
<b>Adjusters:</b> .....	communication connector
.....	2x calibrating and adjusting button
<b>Manual control:</b> .....	with handwheel;
	rotating clockwise (counter-clockwise ) EA output part is moving in direction "Z" ("O")
<b>Local position indication</b> .....	with position indicator visible through aperture in upper cover

### 2.2.1 Mechanical connection

Basic and connecting dimensions are given in dimensional drawings.

### 2.2.2 Electric connection

- **with terminal board (X):** .... max. 24 terminals  
     connecting cable size 1.5 mm<sup>2</sup> (SP 1, SPR 1- 2.4),  
     or 2.5 mm<sup>2</sup> (SP 2 -2.4)  
     3 cable glands - cable diameter from 3,5 to 5mm, 6 to 10,5mm and 8 to 14,5mm – SP(R 1  
     3 cable glands – 2x cable diameter from 6 to 10,5mm and 1x 8 to 14,5 mm – SPR 2 – SPR 2.4
- **with connector (XC):** ..... max. 32 terminals  
     connecting cable size max. 0.5 mm<sup>2</sup>  
     2 cable glands, 1x M25 - cable diameter from 12,5 to 19 mm and 1xM20- cable diameter  
     from 12,5 to 19 mm and 1x from 8 to 14,5 mm.
- **with protection terminal:**  
     external and internal, mutually connected and marked with protection earthing mark

**Electric connection:** according to wiring diagrams.

### 3. Installation and dismantling of actuator



**Abide by safety measures!**

Notes:

Repeatedly verify whether placing of EA corresponds to part "Operating conditions". If actual conditions differ from recommended, it is necessary to consult it with manufacturer.

**Before starting of mounting the EA onto the valve:**

- Check again whether the EA was not damaged during storing.
- Check whether the adjusted operation angle and connecting dimensions of the actuator (see the nameplate) are in compliance with the valve parameters.
- In case of inconsonance, perform adjusting according to the part Adjustment.

#### 3.1 Installation

##### 3.1.1 Mechanical connection

EA is by the producer adjusted to parameters according to the nameplate, with connecting dimensions according to the corresponding dimensional drawing and put it to a mid-position.

Before installation put the handwheel on.

##### Mechanical flange connection

- Properly defat contact surfaces of the EA, connecting flange and the valve/gearing.
- Coat the valve/gearing output shaft firmly with a grease not containing any acid.
- Reset the EA to the limit position "closed"; put the valve to the same limit position.
- Put the EA onto the valve to have the output shaft reliably in the valve/gearing coupling.
- Use the handwheel to turn the EA if needed to reach compliance between holes in the EA flange and the valve.
- Check whether the connecting flange clings to the valve/gearing.
- Fix the flange with four screws (with mechanical ruggedness min. 8G) tightened to allow moving of EA. Then the fixing screws tighten uniformly crosswisely.

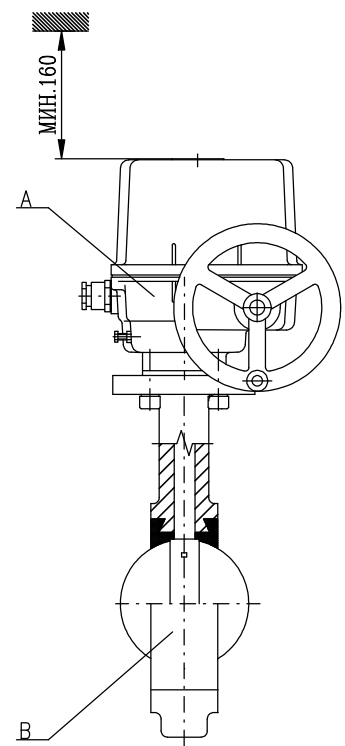

Fig.1

##### Mechanical lever connection (Fig.2)

- Clean contact surfaces of the stand and the base and coat the EA shaft and the pull-rods sliding surfaces with grease.
- Fix the EA to the device with two screws.
- Put the controlled device to the limit position; put the EA with stop ends to the corresponding limit position.
- Put the lever or another output element corresponding with the position as much as possible, in case that the position is not in compliance with required, tune it with the handwheel in range  $\pm 15^\circ$ .
- Connect the EA with the device with the pull-rod consisting of two ball pins and a 1/2" tube according to STN 42 5711 threaded on both ends.
- In EA without stop ends operation angle position can be adjusted with the handwheel, along the whole circumference without changing of setting of the lever.
- While installing take care to have the angle between the lever and the pull-rod at least  $15^\circ$  and at most  $165^\circ$  (Fig.2).

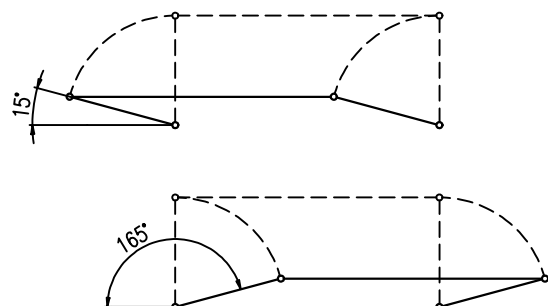

Fig.2

**Notes:**

1. *Minimum mechanical ruggedness of screws is 8G.*
  2. *If adjustment of the position-signaling unit, the transmitter or the position indicator in the production plant do not correspond with the EA connected this way, adjust the units. If adjustment of the stop ends was changed, it is needed to adjust the stop end screws again.*
- In the end of mechanical connection **check correctness of the connection with the valve/gearing** with rotating the handwheel.

**3.1.2 Electric connection and checking of function**

Follow up with connecting the EA with mains or master system.



1. *Follow instructions in the part "Requirements for professional qualification"!*
2. *While laying electrical line abide by the instructions for heavy current installations.*
3. *Cables to terminal boards or connectors lead through cable glands. The cable jacket diameters must conform to the extent specified in Chapter 2.2.2!*
4. *Before initiation ES into operation internal and external protection terminals are needed to be connected.*
5. *Feeding cables are to be fixed to the solid construction at most 150 mm from the cable glands.*
6. *To prevent moisture from entering the actuator around the connecting cables, the cables must be sealed with silicone material at the point of penetration through device shell.*

**Connecting with the master system:**

The EA can be controlled with:

- a built-in position controller
- an external position controller



1. *If the EA is controlled with an external controller using unified signal from a two-wire transmitter (capacitive or resistive with a converter in two-wire connection), it is needed to arrange connecting of the two-wire transmitter loop to electrical earth of the successive external controller!*
2. *Connection can be performed only in one point, in any part of loop out of the EA.*
3. *Electronics of the two-wire transmitters is galvanically insulated that is why it can serve as an external source for supplying of several transmitters (their number depends on current which the source can supply).*

**Connecting to terminal board**

- Check whether the type of current, supply voltage and frequency correspond with data on the nameplate of electric motor.
- Remove the upper cover.
- In case of the single-phase version the phase L1 and the lead N connect to the corresponding terminals. In case of the three-phase version connect the phase cables L1, L2 and L3 to U, V, W (terminals 2, 3, 4), the protection cables to the marked places of internal and external protection terminals.

*For operating of armature without stop ends is needed to connect the positional switches S3, S4 to the power supply of electric motor before S1, S2.*

- Connect the control cables according to the wiring diagram placed into the internal side of the cover.
- Put the cover on and tighten it uniformly crosswisely.
- Tighten the cable cable glands firmly to assure the protection enclosure rate.

**Connection to connector:**

- Check whether the type of current, supply voltage and frequency correspond with data on the nameplate of electric motor.
- Release the connectors shells;
- Insulate the ends of conductors;
- Connect the appropriate sleeve connector by means of recommended pliers;
- Insert the sleeves into appropriate connector contacts according to connecting wiring diagrams.
- Fix the connectors and tighten them;
- Tighten the cable cable glands firmly to assure the protection enclosure rate.



Notes:

1. The EA are delivered with cable glands, which in case of tight putting on the leads assure protection enclosure up to IP 68. For required protection enclosure it is needed to use rings according to the actual cable diameter.
2. While fixing the cable it is needed to count with allowed bend radius to avoid damaging or deformation of the sealing element of the bushing. The leads are to be fixed with the solid construction at most 150 mm from the cable glands.
3. It is recommended to use screened cables to connect remote transmitters.
4. The face areas of the control part cover have to be before re-mounting clean, coated with a grease without any acid (e.g. vaseline) and sealing not damaged to avoid joint corrosion.
5. Reversation of the EA is sure, if the period between switching-off and switching-on of power supply for the reversed movement of the output part is minimally 50 ms.
6. Delay after switching-off, i.e. time since a reaction of switches till the motor is dead can be maximally 20 ms.
7. It is recommended to have the corresponding direction protection switched-off directly with the corresponding position or torque switches.



**Abide by instructions of valve producers, whether switching-off in limit positions is to be realised with position or torque switches.**

**After electric connection perform checking of function:**

- Put the valve manually to a mid-position.
- Connect the EA electrically for the chosen direction of movement and watch the output part movement.
- If it does not correspond change the order of feeding phases (valid for 3x400V version), or change leads of the feeding phase to the corresponding terminals (valid for 230V version).
- Check the control unit switches connection with switching consequently the contacts of the corresponding switches by pressing the control elements during running of the EA (at proper connection) to the chosen direction. In case of proper connection the EA stops or indicates the adjusted position according to switching of the chosen switch. If any of the functions is fault check connecting of the switches according to wiring diagrams.



In the **SPR version** with the built-in electronic controller it is needed to perform **autocalibration** for assuring optimal functioning.

**The procedure is as follows**

Press the button **SW1** for about 2 sec (i.e. till the **D3** diode is got on) to set the controller to the **autocalibration** mode. During this process the controller checks the feedback transmitter and the sense of turning, puts the EA to the positions open and closed, measures inertia mass in the directions "opening" and "closing", and loads the adjusted parameters into the EEPROM memory. In case that during the initialization process an error occurs (e.g. in connection or adjustment) the initialization process will be interrupted and the controller with the **D4** diode reports about the type of the error. Else after finishing the initialization process the controller is put into the **regulation mode**. If needed to change adjusted parameters of the controller follow instructions given in the part Adjusting of actuator.

**3.2 Dismantling**



**Before dismantling it is required to disconnect the EA from mains!  
Do not connect and disconnect live connectors!**

- Disconnect the EA from mains.
- Disconnect the leads from the EA terminal boards and loosen the cables from cable glands. Pull out the connectors in case of the connector version.
- Loosen the fixing screws of the EA flange and disconnect the EA from the valve/gearing.
- While sending the EA to be repaired put it into a package solid enough to avoid damages of the EA during transportation.

## 4. Adjusting of actuator



**Abide by safety measures!**

After mechanical connection, electrical connection and checking of connection and function start setting and adjustment of the device. The adjustment can be performed at a mechanically and electrically connected EA. This part describes adjustment of EA to specified parameters in case that any unit of EA is reset. Laying of adjusters of the control board is shown on Fig.3.

### 4.1 Adjustment of torque unit

In the production plant switching-off torque for both the "opening" direction (the torque switch S1, or S11) as well as for the "closing" direction (the torque switch S2, or S22 ) are adjusted to specified value  $\pm 10\%$ . If not agreed else they are adjusted to maximum value.

Adjustment and setting of the torque unit to other values without any testing device for torque measuring is not possible.

### 4.2 Adjustment of position-indicating unit (Fig.4)

The EA are in the production plant adjusted to a fixed angle (according to the specification), given on the nameplate. While setting, adjusting and resetting follow these steps (Fig. 4):

- In the version with a transmitter put the transmitter out of mesh.
- Loosen the nuts (23) fixing cams still having the Belleville spring creating axial pressure.
- Put the EA to the position "open" is to be end turn the cam (29) clockwise until the switch S3 (25) switches.
- Change setting of the EA by the angle, where the position "open" is to be indicated and turn the cam (31) clockwise until the switch S5 (27) switches.
- Put the EA to the position "closed" and turn the cam (28) counter-clockwise until the switch S4 (24) switches.
- Turn the EA back by the angle, where the position "closed" is to be indicated and turn the cam (30) counter-clockwise until the switch S6 (26) switches.
- Having the EA adjusted lock the cams with the central milled nut and counter-nut (23).

If not agreed else the signaling cams are set next to the limit positions. The signal possibility is available along the whole operation angle in both directions, i.e. 100%.

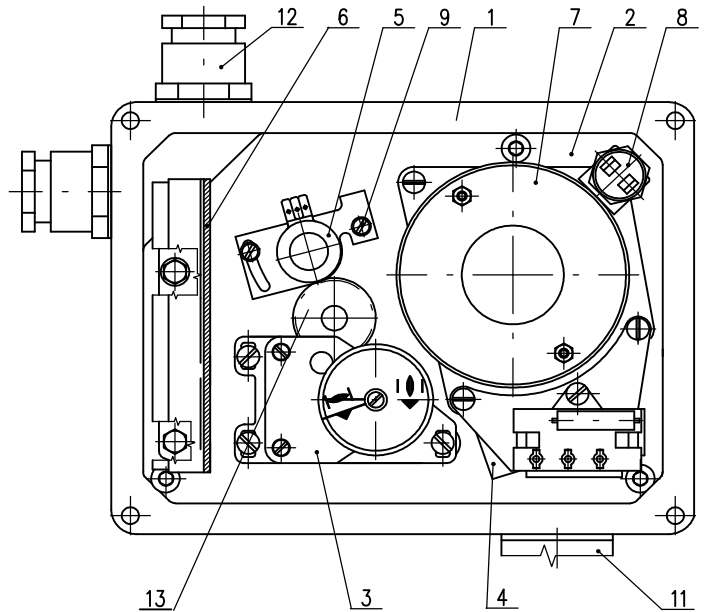

Fig. 3

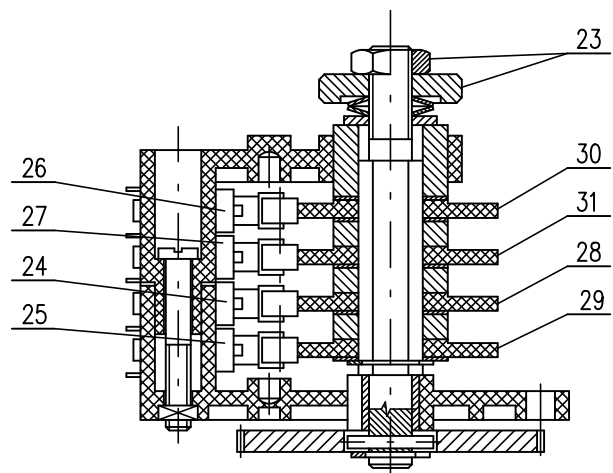

Fig. 4

### 4.3 Adjustment of resistant transmitter (Fig.5)

The **resistant transmitter** is in the EA **SP** used to function as a remote position indicator; in the EA **SPR** to function as a feedback in the position controller and if needed also in the position of a remote resistant position indicator.

Before the resistant transmitter adjustment the position switches have to be adjusted. Adjustment consists in setting of the resistance in the defined limit position of the EA.

Notes:

1. While adjusting the EA with double resistant transmitter only the resistance of one section is to be adjusted because of the mechanical connection of the both sections.
2. In case that the EA is not used in the whole stroke range given on the nameplate, the resistance in the limit position "open" is proportionally reduced.
3. In the EA **SPR** 2000W resistant transmitters are used. In the other cases if the resistant branch is lead to the terminal board the resistance of the transmitters is according to the customer's specification.

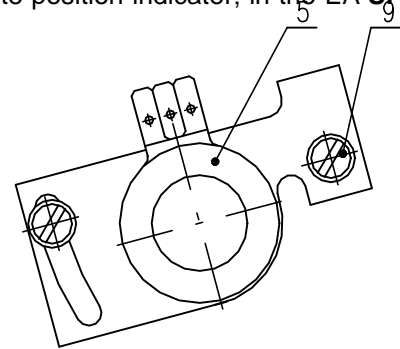

Fig. 5

To adjust the transmitter follow these steps:

- Loosen the fixing screws (9) of the transmitter holder and push the transmitter out of mesh.
- Connect the measuring instrument for measuring the resistance to terminals 71 and 73 on the Electric actuator local control terminal box, or to terminals 7 and 10 on the Electric actuator local control controller with the controller with the disconnected supply voltage to Electric actuator and with the disconnected input signal into the controller (terminals 86-88).
- Connect a meter for resistance measuring to the terminals 71 and 73 of the EA **SP** terminal board, or to the terminals 7 and 10 of the EA **SPR** terminal board.
- Put the actuator to the position "closed" (with the handwheel, or with the local electric position control until the corresponding position switch S2 or S4 switches).
- Rotate the transmitter shaft until resistance of  $\leq 5\%$  of the nominal transmitter resistance can be read on the meter in case of EA **SP**, and 3 up to 7% of the nominal transmitter resistance in case of EA **SPR**, i.e. with the resistant transmitter with the converter PTK1.
- In the position put the transmitter to mesh with the drive wheel and fix the fixing screws on the transmitter holder. Disconnect the meter from the terminal board.
- If when in the open position, the value of the resistance of the transmitter is greater than permitted, then the working stroke must be reduced.

**4.4 Adjustment of the Electronic Position Transmitter (EPV) - the Resistive Transmitter (Potentiometer) with the Converter PTK 1**

**4.4.1 EPV – the 2-wire version (Fig. 6,6a)**

The position transmitter with the converter PTK1 is in the plant adjusted to have the output current signal on the terminals 81-82 as follows:

- in the position "open" ..... 20 mA resp. 5 mA
- in the position "closed" ..... 0 mA resp.4 mA

**Adjustment of the EPV in Electric Actuators SP**

If the transmitter requires a new adjustment follow these steps:

- Put the actuator to the position "closed" and switch the power supply off.
- Adjust the resistive transmitter according to the previous chapter. The resistance is to be metered on the terminals X-Y (Fig. 6,6a). The used transmitter resistance is 100 Ω.
- Switch the converter's power supply on.
- Turn the adjusting trimmer ZERO to adjust the output current signal rate measured on the terminals 81-82 to 4mA.
- Set the actuator to the position "open".
- Turn the adjusting trimmer GAIN to adjust the output current signal rate measured on the terminals 81-82 to 20mA.
- Check the output signal of the converter in the both limit positions, and repeat the procedure if needed.

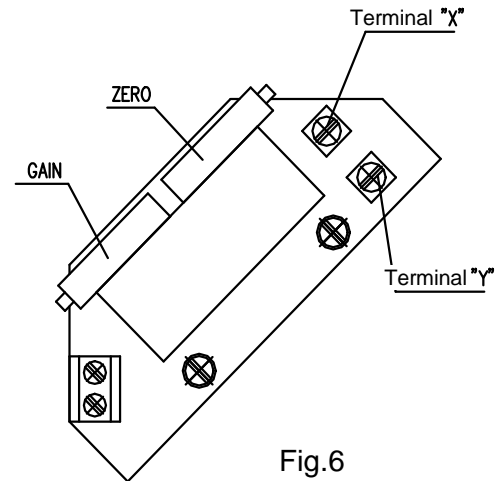

Note:

The output signal of 4-20mA can be adjusted at the range from 75 up to 100% of the rated stroke stated on the actuators nameplate. At values less than 75% the value 20mA is reduced proportionally.

**Adjustment of the EPV in Electric Actuators SPR with controllers**

- Disconnect the circuit with removing a jumper on the terminals 81 and 82.
- Disconnect the control signal from the terminals 86/87 and 88.
- Set the actuator to the direction "OPENING" or "CLOSING" with the handwheel, or with connecting power to the terminals 1 and 20 for the direction "OPENING" or 1 and 24 for the direction "CLOSING".
- Set the actuator to the position "CLOSING" and switch the converter off on the terminals 1 a 61.
- Adjust the resistive transmitter according to the previous chapter. The resistance is to be metered on the terminals X-Y (Fig. 6,6a).
- Connect power supply to the terminals 1 and 61.
- Turn the adjusting trimmer ZERO to adjust the output current signal rate measured on the terminals 81-82 to 4mA.
- Set the actuator to the position "open".
- Turn the adjusting trimmer GAIN to adjust the output current signal rate measured on the terminals 81-82 to 20mA.
- Check the output signal of the converter in the both limit positions, and repeat the procedure if needed.
- Having the transmitter adjusted put the jumper again on the terminals 81 and 82 in case that the output signal wont be used (the circuit through the terminals 81 and 82 should be closed).
- Connect the control signal to the terminals 86/87 and 88.

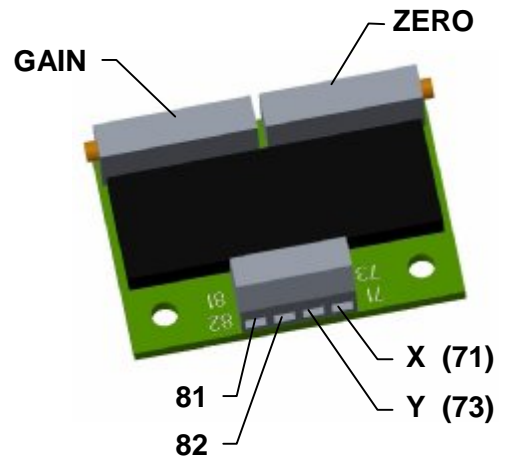

#### 4.4.2 EPV – 3-wire version (Fig. 7,7a)

The resistive transmitter with the converter is in the plant adjusted to have the output current signal metered on the terminals 81-82 as follows:

- in the position "open" ..... 20 mA resp. 5 mA, resp. 10 V
- in the position "closed" ..... 0 mA resp. 4 mA, resp. 0 V

according to the specified version of the converter.

If the transmitter requires a new adjustment follow these steps:

- Put the actuator to the position "closed" and switch the power supply off.
- Adjust the resistive transmitter according to the previous chapter. The resistance is to be metered on the terminals X-Y (Fig. 7,7a). The used transmitter resistance is 2000  $\Omega$  or 100  $\Omega$ .
- Switch the converter's power supply on.
- Turn the adjusting trimmer ZERO to adjust the output current signal rate measured on the terminals 81-82 to 0 mA or 4mA.
- Set the actuator to the position "open".
- Turn the adjusting trimmer GAIN to adjust the output current signal rate measured on the terminals 81-82 to 20mA or 5 mA.
- Check the output signal of the converter in the both limit positions, and repeat the procedure if needed.

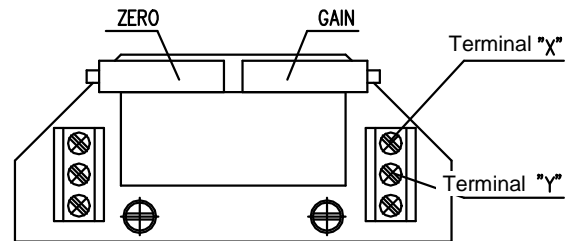

Fig. 7

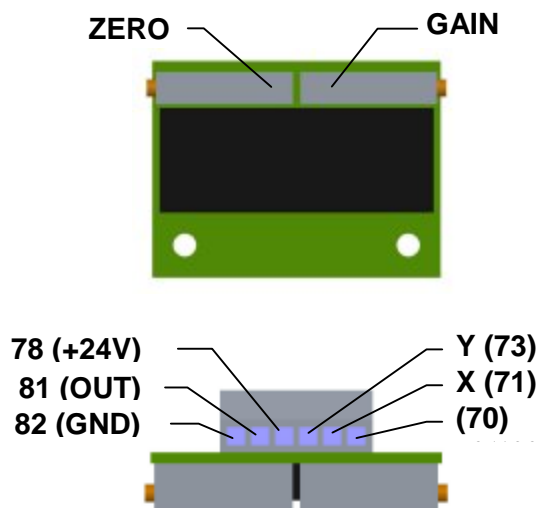

Fig.7a

Note:

The output signal of (0-20mA, 4-20mA or 0-5mA - according to the specification) can be adjusted at the range from 85 up to 100% of the rated stroke stated on the actuator's nameplate. At values less than 85% the value of the output signal is reduced proportionally.

## 4.5 Adjustment of Capacitive Transmitter CPT1/A

The chapter describes adjustment of the capacitive transmitter to the specified parameters (standard values of output signals) in case they are reset. The capacitive transmitter serves as a position transmitter of electric actuators with unified output signal of 4÷20 mA in electric actuators **SP**, or as a feedback of a position controller, or if required it functions also as a remote position transmitter of electric actuators with unified output signal of 4÷20 mA in electric actuators **SP with controllers**.

### Note:

*In case that reversed output signals are needed (in the position "OPEN" minimum output signal) contact personnel of service centres.*

The capacitive transmitter CPT1/A is adjusted by the producer to the fixed Operating angle according to the order and wired according to the wiring diagrams placed into the cover. Check the power supply of the user after connecting to terminal of the terminal board before the transmitter is electrically checked. Adjustment of the capacitive transmitter can be performed when the position switches are adjusted. The adjustment is performed with the power supply of 230 V/50 Hz and ambient temperature of  $20 \pm 5^\circ\text{C}$ .

The following versions of electric actuators with built capacitive transmitters can be specified:

- A) The version without any power supply** (2-wire version) for EA **SP**
- B) The version with a power supply** (2-wire version) for EA **SP**
- C) The version CPT as a feedback to the position controller** for EA **SP with controllers**

### A.) Adjustment of the Capacitive Transmitter without any Power Supply

Before connecting check the power supply. The measured voltage should be in range from 18 up to 28 V DC.



*The voltage of the power supply must not be in any case higher than 30 V DC. The transmitter can be irreversibly damaged!*

While checking or adjusting the output signal of 4÷20 mA follow these steps:

- Connect a mA meter of precision class 0,5 and loading resistance lower than  $500 \Omega$  serially with the transmitter (pole "-"; terminal 82)
- Put the actuator to the position "CLOSED", the signal value should decrease.
- Check the signal value for the position "CLOSED" (4 mA).
- Tune the signal with loosening the fixing screws (15) and turning the trimmer (10) until the required value of 4 mA is reached. Tighten the fixing screws.
- Put the actuator to the position "OPEN", the signal value should raise.
- Check the signal value for the position "OPEN" (20 mA).
- Tune the signal with turning the trimmer (20) until the required value of 20 mA is reached.
- Check the signal value for the position "CLOSED" and then for the position "OPEN".
- Repeat the procedure until the change from 4 to 20 mA is reached with deviation less then 0,5 %.
- Disconnect the meter and lock the screws with a varnish.

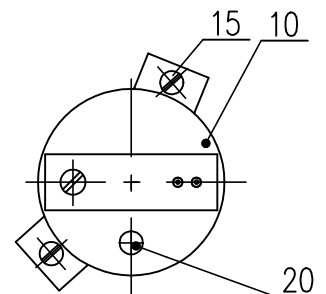

Fig.8

### B.) Adjustment of the Capacitive Transmitter with the Power Supply

1.) Check the power supply: 230 V AC  $\pm 10\%$  on the terminals 78,79

2.) While checking or adjusting the output signal of 4÷20 mA follow these steps:

- Connect a mA meter of precision class 0,5 and loading resistance lower than  $500 \Omega$  on the terminals 81, 82.
- Follow the procedure described in the previous chapter A.

### C.) Adjustment of the Capacitive Transmitter Served as a Feedback of the Position Controller

While checking or adjusting the output signal of 4÷20 mA follow these steps:

- Disconnect the circuit on the terminals 81 and 82 removing the jumper.
- Connect power supply to the terminals 1 and 61.
- Disconnect the control signal from the terminals 86 and 88.
- Put the actuator to the direction "OPENING" or "CLOSING" with the handwheel or connecting power supply to the terminals 1 and 200 for the direction "OPENING", or 1 and 24 for the direction "CLOSING".
- Connect a mA meter of precision class 0,5 (e.g. digital) and loading resistance lower than  $500 \Omega$  on the terminals 81,82.
- Follow the procedure for the version without any power supply described in the previous chapter A.

- Having the transmitter adjusted put the jumper again on the terminals 81 and 82 in case that the output signal wont be used (the circuit through the terminals 81 and 82 should be closed).
- Connect the control signal to the terminals 86 and 88



*The user has to arrange grounding of the 2-wire circuit of the capacitive transmitter to the electrical ground of a joined controller, computer, etc. The grounding should be performed only in one place in any part of the circuit outside the electric actuator!*

Note:

*The trimmer (20) can be used to adjust the output signal of the capacitive transmitter to any value of Operating angle in range from ca 40% up to 100% of the value of the Operating angle adjusted by the producer and stated on the actuator's nameplate.*

#### **4.6 Resetting of operation angle and setting of stop end screws (Fig.9)**

The valve operation angle position is defined with the stop end screws which allow to change the position from the position "Z" (closed - 0°) and from the position "O" (open - 60°, 90°, 120°, 160°) by a value of ±15°. For better understanding see Fig. 9 where the output shaft is in the position "Z" for the operation angle of 90°. The stop end screws serve as mechanical limits of the operation angle position at manual control or as end travel points for torque switching-off, else the mechanical gearing could be damaged.

Note:

*The stop end screws allow to extend or to reduce the operation angle by 30° in the adjusted EA, but output shaft position cannot be tuned. Also the position unit is to be adjusted to this angle and the transmitter has to be out of mesh.*

##### **4.6.1 Setting of stop end screws at position-unit switching-off**

If the EA is equipped with the torque switches they function as limit switches in case of position-unit switching-off failure, or as protection against overload.

The procedure is as follows:

- Loosen the counter-nut of the stop end screw "Z".
- Rotate the stop end screw to right until you feel an increased resistance while touching the end. From this status turn the screw min. by 1/2 of revolution back to avoid torque switching.
- Lock the screw with the counter-nut.
- Use similar steps to set the stop end screw for the position "O".

##### **4.6.2 Setting of stop end screws at torque switching-off (Fig.9)**

In case the stop ends screws function as limit points (stop ends) of the EA output shaft travel the EA torque unit is to be adjusted not to have the switching-off torque exceeded.

The procedure is as follows:

- Put the EA with the handwheel to the position "Z" (closed).
- Loosen the counter-nut of the stop end screw "Z".
- Rotate the stop end screw to right until you feel an increased resistance while touching the end - lock the screw with the counter-nut.
- Use similar steps to set the stop end screw for the position "O".
- Adjust the position-signalling unit to switch-off before torque switching-off.

Type	A	B	C	D	S
SP 1/SPR 1	26	13	11	M8	13
SP 2/SPR 2	46	18,5	16	M10	16
SP 2.3/SPR 2.3	34	12,5	10	M12	19
SP 2.4/SPR 2.4	44	15,5	12,5	M14	22

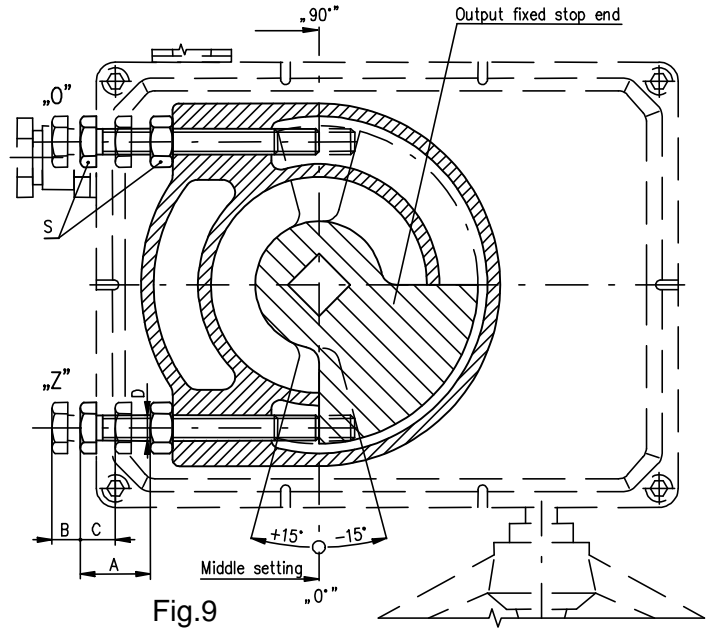

**4.7 Adjustment of position controller (Fig. 10)**

The built-in position controller REGADA of new generation is a user-friendly control system to control actuators with an analogue signal. The controller takes advantages of high-power RISC processor MICROCHIP to perform all functions. It provides also continuous automotive diagnostics of the system, error messages as well as number of relay switching and number of controller's operation hours. Placing an analogue signal onto the input terminals of the terminal board 86/87 (GND, -) and 88 (+) causes that the EA output is reset.

Required parameters and functions can be programmed using function buttons SW1 - SW2 and LED diodes D3 - D4 placed directly on the controller, see Table 2.

**4.7.1 Setting of controller**

The controller's microprocessor unit is in the production plant programmed to parameters given in **Table 2** (Note 2).

Setting of the controller is performed using buttons and LED diodes.

Adjust the position and torque switches and the position transmitter before adjustment of the controller.

Laying of adjusters and signaling elements on the board of the REGADA controller is shown on Fig. 10:

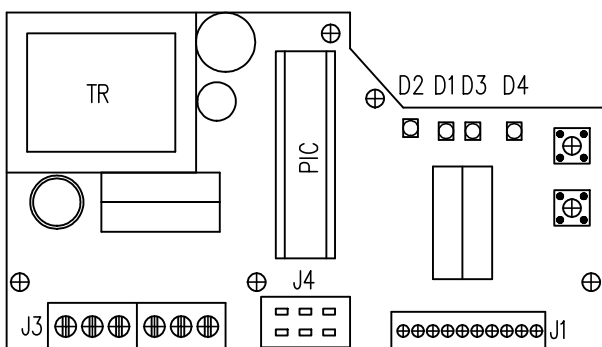

Fig.10

<b>SW1 button</b>	starts an initialization routine an allows listing in the adjust menu
<b>SW2 button</b>	setting of parameters in the chosen menu
<b>D1 diode</b>	power on indication
<b>D2 diode</b>	motion to the direction "opening" indication (green) - "closing" (red) indication
<b>D3 diode</b>	(yellow light) number of blinking codes indicates chosen adjust menu
<b>D4 diode</b>	(red light) number of blinking codes indicates adjusted parameter of the controller from the chosen menu



**Table 2:**

D3 (yellow) diode number of blinking	Adjust menu	D4 (red) diode number of blinking	Adjusted parameter
1 blink	control signal	1 blink	0-20mA
		2 blinks	<b>4-20 mA (*) (**)</b>
		3 blinks	0-10V DC
2 blinks	response for signal SYS-TEST	1 blink	EA opens receiving signal SYS
		2 blinks	EA closes receiving signal SYS
		3 blinks	<b>EA stops receiving signal SYS (*)</b>
3 blinks	mirroring (ascending/descending characteristics)	1 blink	EA CLOSING at increasing of control signal
		2 blinks	<b>EA OPENING at increasing of control signal (*)</b>
4 blinks	insensitiveness of controller	1 to 10 blinks	insensitiveness of controller of 1-10% (3% set by the producer) (*)
5 blinks	way of regulation	1 blink	narrow torque
		2 blinks	<b>narrow position (*)</b>
		3 blinks	wide torque
		4 blinks	wide position

Notes:  
 1. The controller at autocalibration automatically sets the feedback type - resistant/current  
 2. (\*) Parameters set in the production plant, if customer has not stated else.  
 3. (\*\*) Input signal        4 mA - position "closed"  
                                  20 mA - position "open"

**Standard setting of controller (programmed RESET of controller)** - in case of any problems with setting of the parameters it is possible with pressing both **SW1** and **SW2** at the same time and then switching power on to set the standard parameters.

**Controller setting procedure:**

The initialization routine starts at the switched-on controller, zero system deviation and short pressing of the SW1 button for ca 2 sec (i.e. until the diode D3 got on). Loosing the button some of the default menus starts (usually control signal) what is shown with 1 blink on the D3 diode as well as one of the default parameters (usually control signal of 4-20mA) what is shown with 1 blink on the D4 diode. Then the required parameters of the controller can be changed according to Table 2:

- press shortly the SW1 button to list the menu shown with the blinking number on the D4 diode.
- press shortly the SW2 button to set parameters shown with the blinking number on the D4 diode.

After changing the parameters according to the user's requirements, switch the controller to autocalibration using the SW1 button pressed for approx. 2 sec (i.e. until the diode D3 lights up), which is signaled by flashing the yellow LED D3 6 times. During this process, the controller checks the feedback transmitter and the direction of rotation, moves the ES to the open and closed positions, measures the inertial masses in the "OPEN" and "closes" directions and saves the set parameters in the EEPROM memory. In case that during the initialization process an error occurs (e.g. in connection or adjustment) the initialization process will be interrupted and the controller with the D4 diode reports about the type of the error. Else after finishing the initialization process the controller is put into the regulation mode.

**Error messages of the controller with D4 diode at initialization**

- 4 blinks.....improper connection of the torque switches
- 5 blinks.....improper connection of the feedback transmitter
- 8 blinks.....bad sense of actuator's turning direction or adverse connection of the feedback transmitter

**4.7.2 Watching operation and error states**

Watching operation and error states is possible with the EA open.

**a) Operation status with the D3 LED diode indicating:**

- it is continuously lighting - the controller regulates
- it is continuously not lighting - system deviation in the insensitiveness range - the EA has stopped

**b) Error state with the D4 and D3 LED diodes indicating - D4 continuously lighting,  
D3 indicates error state with blinking**

<b>1 blink</b> (repeated)	indication of the "TEST" mode - the EA is put to the position according to the signal in the "TEST" menu (at connecting the 66 and 86/87 terminals)
<b>2 blinks</b> (repeating after short pause)	missing of control signal - the EA is put to the position according to the signal in the "TEST" menu
<b>4 blinks</b> (repeating after short pause)	torque switches activity indication (the EA switched-off with the torque switches in a mid-position)
<b>5 blinks</b> (repeating after short pause)	failure of the feedback transmitter - the EA is put to the position according to the signal in the "TEST" menu
<b>7 blinks</b> (repeating after short pause)	control signal (current at range 4-20mA less than 4mA (3.5mA)).

## 5. Service, maintenance and troubleshooting

### 5.1 Service



1. In general it is provided that service of the EA is performed by a qualified worker in accordance with requirement given in Chapter 1!
2. After putting the EA into operation it is needed to verify whether during manipulation any scratch on surface occurred, it is to be removed to prevent actuator against corrosion!

- The EA SP/SPR requires just negligible service. Proper putting into operation is a recondition of reliable operation.
- The service of the EA leads from the operation conditions and usually resides in information processing for further arranging of required functions.
- The stuff has to perform prescribed maintenance to prevent the EA during operation against impacts of environment, which exceed the frame of allowed influences.

#### Manual control:

If needed (during adjusting, function checking, failure etc.) the stuff can change setting of the controlled body using the handwheel. While rotating the handwheel clockwise the output part moves in the direction "closed".

#### Electric local control: - additional equipment (Fig.11)

In case of need (during adjusting, function checking etc.), but power supply must be provided, is possible to readjust actuator by electric local control. After switching the mode switch to the mode "LOCAL" it is possible by the direction switch to control motion of the output part to setting direction. Signal lights indicate achievement of limit position at relevant direction

The control is possible after removing the padlock (1). Control mode selection is changed by sequential pressing of the button (2) **REMOTE-OFF-LOCAL** to "Remote" "Shut off", "Local", "Shut off". Individual modes are cycled by sequential pressing. The selection is indicated by LEDs visible on the front panel of the local control.

The presence of the supply voltage for the control of the local control is signalled by the lighting of one of the three LEDs REMOTE (6), OFF (7), or LOCAL (8).

#### Individual local control modes:

"OFF" mode - in this mode, the EA cannot be controlled remotely or locally. The mode is signalled by the lighting of the OFF LED (7).

The „**LOCAL**“ mode - this mode enables EA control in the open and close direction and to stop using buttons **OPEN** (3) (open), **CLOSE** (4) (close) and **STOP** (5). The „**LOCAL**“ mode is indicated by **LOCAL** (8) LED being lit. When **OPEN** button is pressed in this mode, it is indicated by **OPEN** LED being lit (9). When **CLOSE** button is pressed in this mode, it is indicated by **CLOSE** LED being lit (10). When **STOP** button is pushed, the signal LEDs **OPEN** (9) and **CLOSE** (10) are switched off.

The „**REMOTE**“ mode - in this mode the EA can be remotely controlled by commands from master system. The „**REMOTE**“ mode is indicated by **REMOTE** (7) LED being lit. In this mode the OPEN, STOP and CLOSE buttons are not functional.

After finishing the work with electrical local control, we recommend to return the padlock to button (2) in mode „**REMOTE**“ and lock out the device to avoid unwanted tampering by unauthorized person. Padlock can be fitted and locked to button (2) in any local control mode.

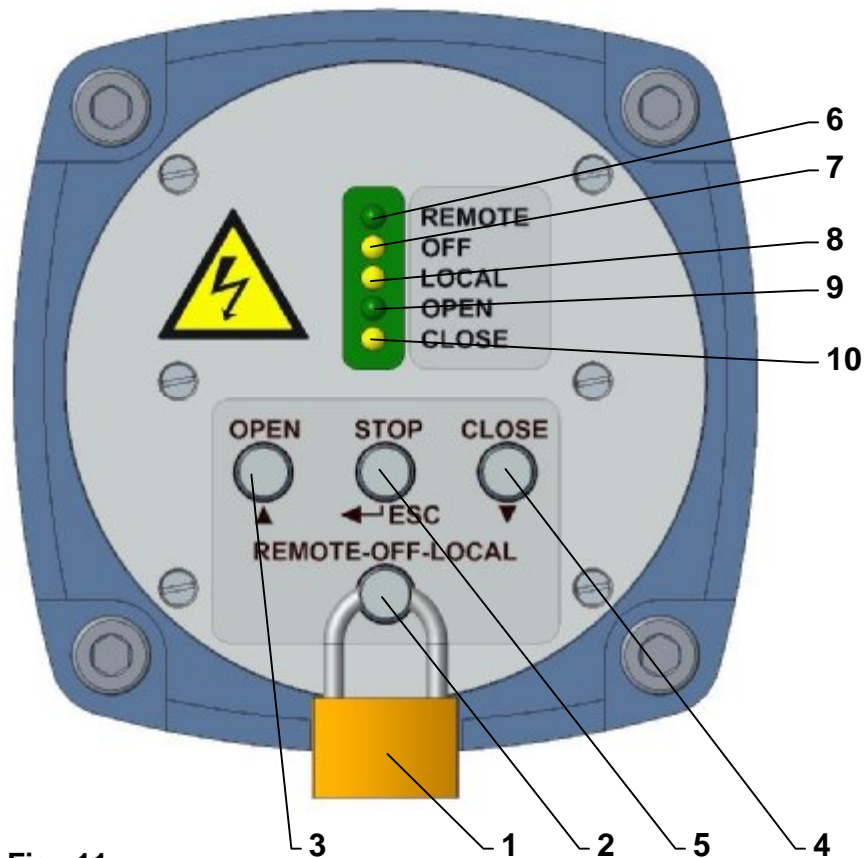

Fig.. 11

## 5.2 Maintenance - extent and periodicity

During inspections and maintenance is needed to tighten all screws and nuts that affect the tightness and coverage. Similarly, once a year should be checked and if necessary tighten mounting screws of the terminal wires and assuring of the slip-on joints with wires.

The interval between two preventive inspections is four years.

The replacement of cover gaskets and gasket of an oil filling is needed in case of damage or after 6 years of the operation.

The grease in the supplied actuators is designed for the lifetime of the product.

It is not necessary to change the grease during the operation of the actuator.

### Lubrication:

- gear part - in versions for climate with temperatures  $-25^{\circ}\text{C}$  till  $+55^{\circ}\text{C}$  – grease HF 401/0 (GLEIT- $\mu$ ) resp. GLEITMO 585 K
- in versions for climate with temperatures  $-50^{\circ}\text{C}$  till  $+40^{\circ}\text{C}$  grease ISOFLEX TOPAS AK 50.
- in versions for climate with temperatures  $-60^{\circ}\text{C}$  till  $+40^{\circ}\text{C}$  grease DISCOR R-EP 000.



**Lubrication of the valve stem is independent on maintenance of the EA!**

After every potential flooding of the product check, whether there is no water inside. After eventual water penetration, dry the product before repeated putting into operation and replace damaged sealings, resp. other parts of EA. identically check also tightness of cable bushings and replace them, if they are damaged.

- Every six months it is recommended to perform one check move in frame of adjusted operation stroke to verify reliability of functioning with setting back to the original position.
- If the audit rules do not determine else the inspection of EA is performed ones a year and tightening of all connecting and grounded screws have to be checked to avoid overheating.
- After 6 months from putting of EA into operation and once a year it is recommended to check tightening of fixing screws between the EA and the valve. (Tighten the screws with the cross system.)



- While connecting and disconnecting of the EA check the tightness of cable glands – those with damaged sealings should be replaced by new ones of the approved type!
- Keep the EA clean and take care about removing impurities and dust. The cleaning has to be performed regularly according to the operation possibilities and requirements.

### 5.3 Troubleshooting

At failure of power supply the EA stops in the position where it was before the failure. If needed the EA can be set only with the manual control (the handwheel). After restoration of power the EA is prepared for operation.

In case of failure of any element of the EA it can be changed by a new one. Entrust the change to a service centre.

In case of an EA failure, which cannot be eliminated directly in operation, follow instructions for under-guaranty and after-guaranty service.

For controller repair a F1,6 A subminiature fuse for PCB should be used, alternatively also F 2A, 250 V e.g. Siba type 164 050.1,6 or MSF 250, and for DB ... voltage source repair a M160 mA, 250V fuse, e.g. Siba, or MSF 250.

Note:

If the EA requires dismantling follow the chapter "Dismantling".



Taking the EA to pieces for repair purposes is allowed only by professionally qualified persons trained in the production plant or by a contracted service centre!

## 6. Accessories and spare parts

### 6.1 Accessories

The EA is delivered with the **handwheel and cable glands**.

### 6.2 Spare part list

Spare part	Order Nr.	Position	Figure
Electric motor; 4W/; 230V AC	63 592 309	7	3
Electric motor; 15W; 230V AC	63 592 311/63 592 306	7	3
Electric motor; 15W; 3x400V AC	63 592 332	7	3
Electric motor; 20W/; 230V AC	63 592 118	7	3
Electric motor; 40W; 230V AC	63 592 325	7	3
Electric motor; 60W; 230V AC	63 592 079	7	3
Electric motor; 90W; 3x400V AC	63 592 328	7	3
Electric motor; 32 W; 24 V AC/DC	63 592 388	7	3
Electric motor; 93 W; 24 V AC/DC	63 592 294	7	3
Electric motor, 18W; 120 V AC	63 592 060	7	3
Micro-switch CHERRY DB6G-B1RB	64 051 220	3,4	3
Resistant wire transmitter (potentiometer) 1x100Ω	64 051 812	5	3
Resistant wire transmitter (potentiometer) 2x100Ω	64 051 814	5	3
Resistant wire transmitter (potentiometer) 1x2000Ω	64 051 827	5	3
Resistant wire transmitter (potentiometer) 2x2000Ω	64 051 825	5	3
Capacitive Transmitter CPT1/A	64 051 499	10	8
Sealing (SP 1, SPR 1) – IP 65	04 709 000	1	3
Sealing (SP 2-2.4, SPR 2-2.4) – IP 65	04 714 700	1	3
Sealing (SP 1, SPR 1) – IP 67	62 732 170	1	3
Sealing (SP 2-2.4, SPR 2-2.4) – IP 67	62 732 119	1	3
Cable glands M12	63 456 579	12	3
Cable glands M16	63 456 595	12	3
Cable glands M20	63 456 596	12	3
Terminal board EKL - (SPR 1)	63 345 710	6	3
Terminal board EKL - (SPR 2;SPR 2.3;SPR 2.4)	63 345 601	6	3

**Warning:** By supplying spare parts, the manufacturer is not responsible for damages caused by their disassembly and assembly. Installation, replacement of spare parts must be performed by authorized, qualified personnel.

## 7. Enclosures

### 7.1 Wiring diagrams

#### Wiring diagrams electric actuator SP

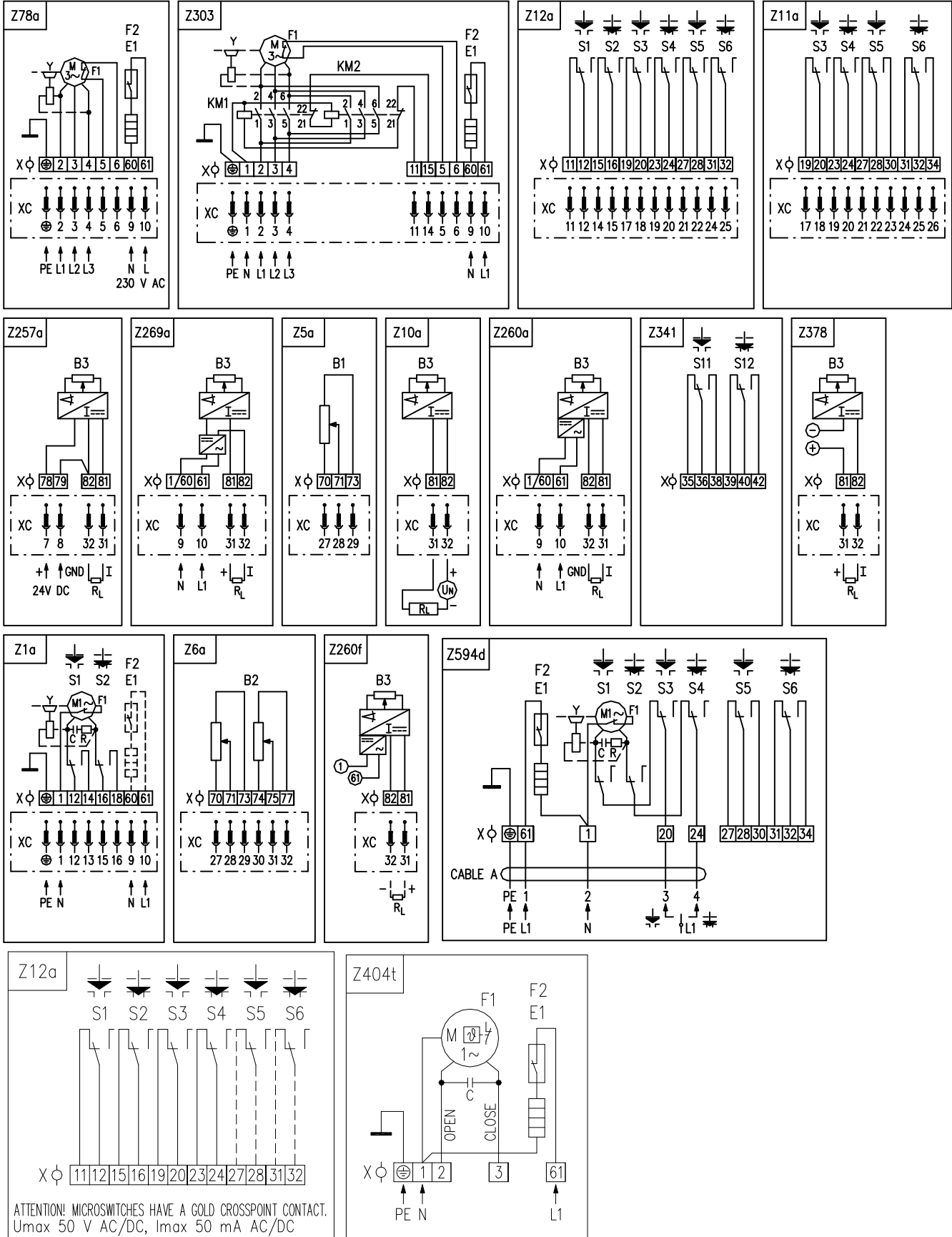

Wiring diagrams electric actuator SP 2 - SP 2.4 – Electric connection to terminal board

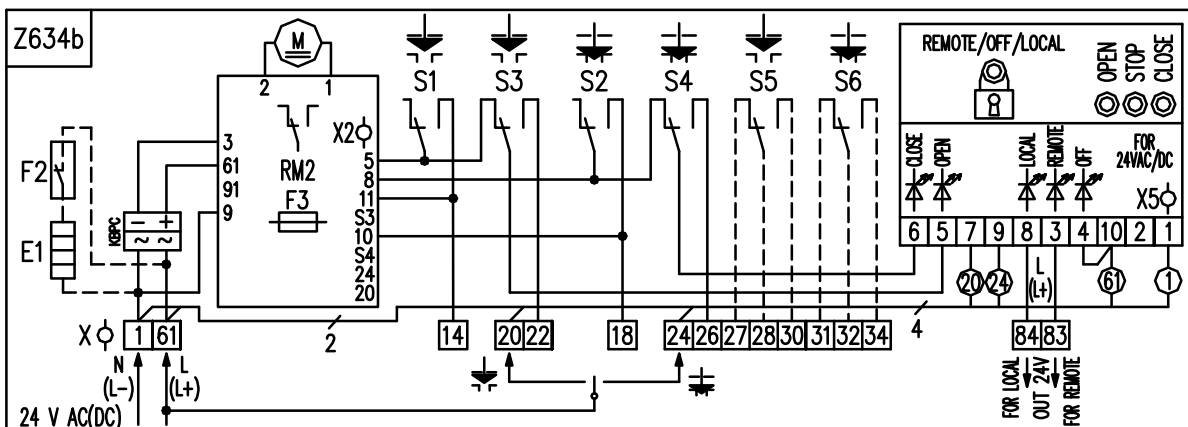
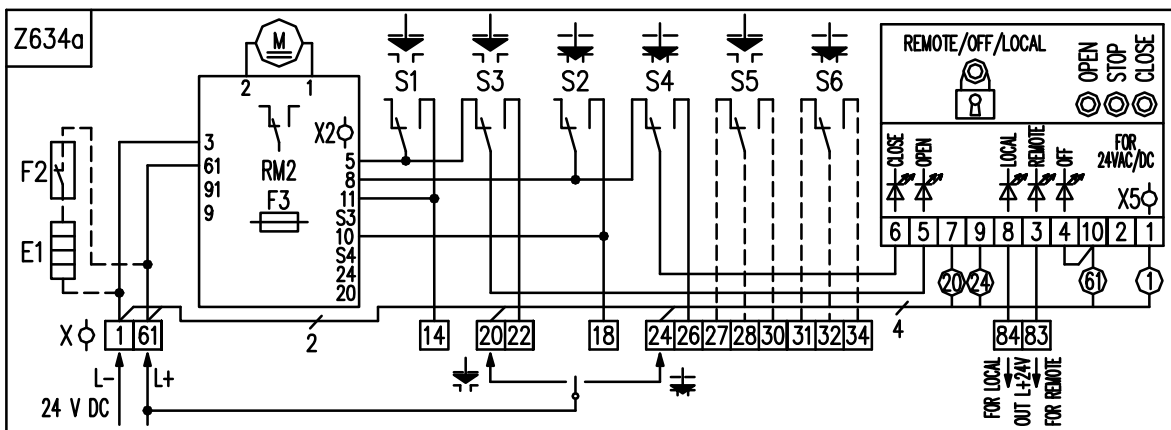
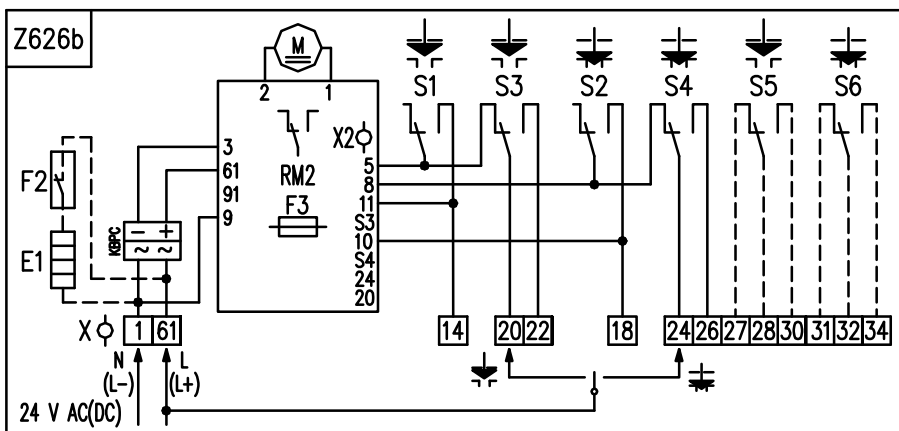
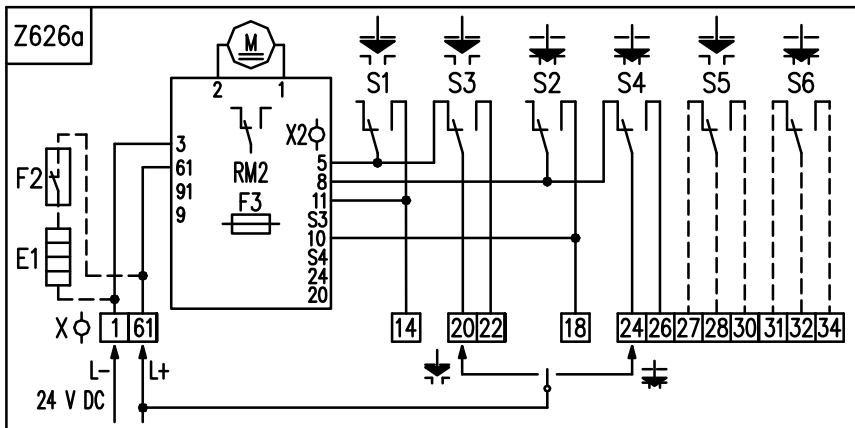

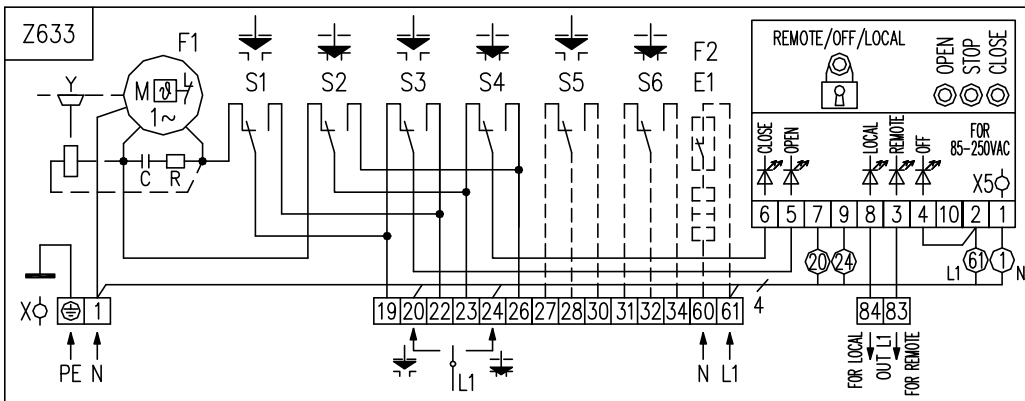
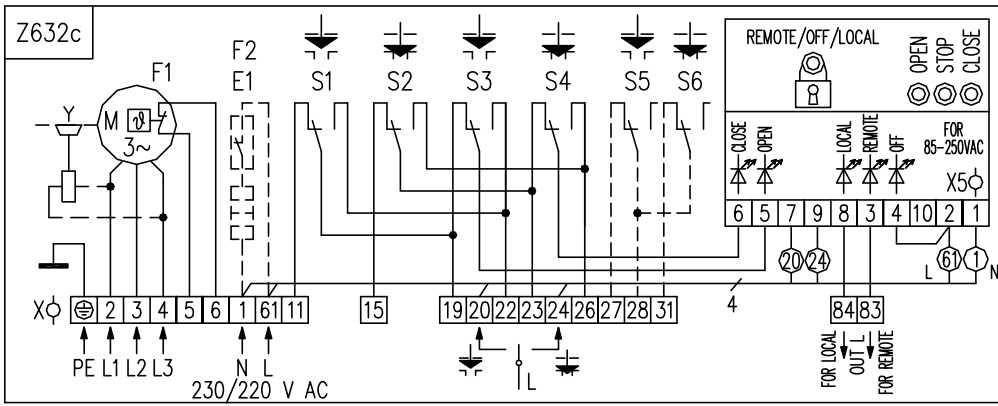
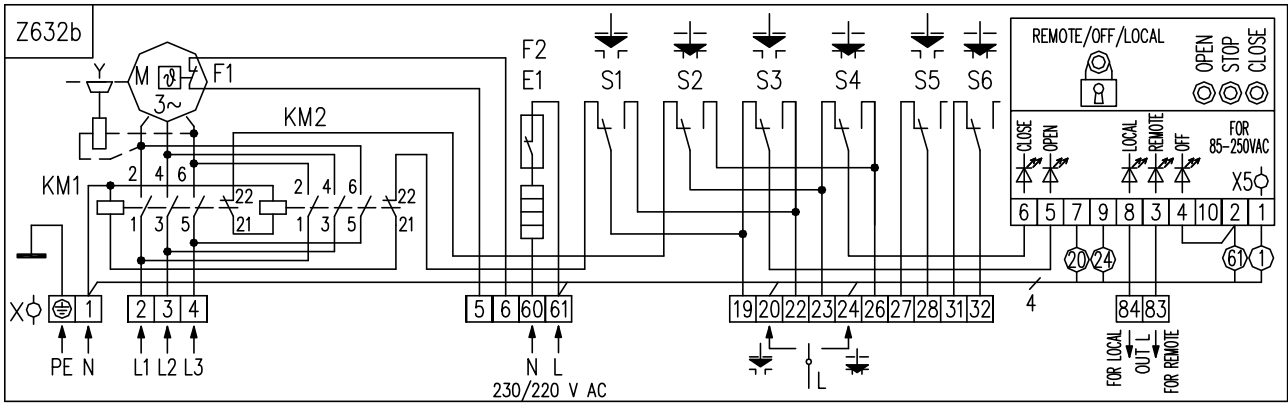



Wiring diagrams electric actuator ES SP 2 - SP 2.4 – Electric connection to connector

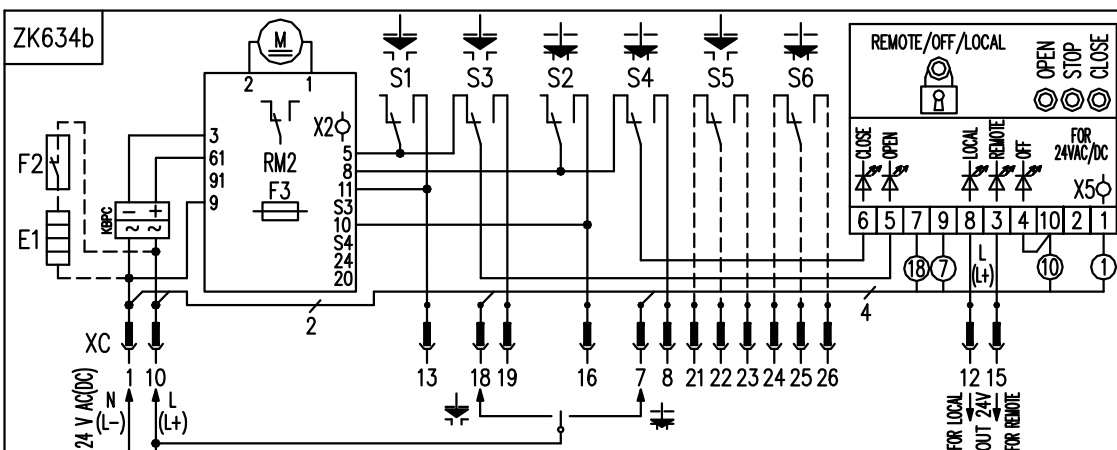
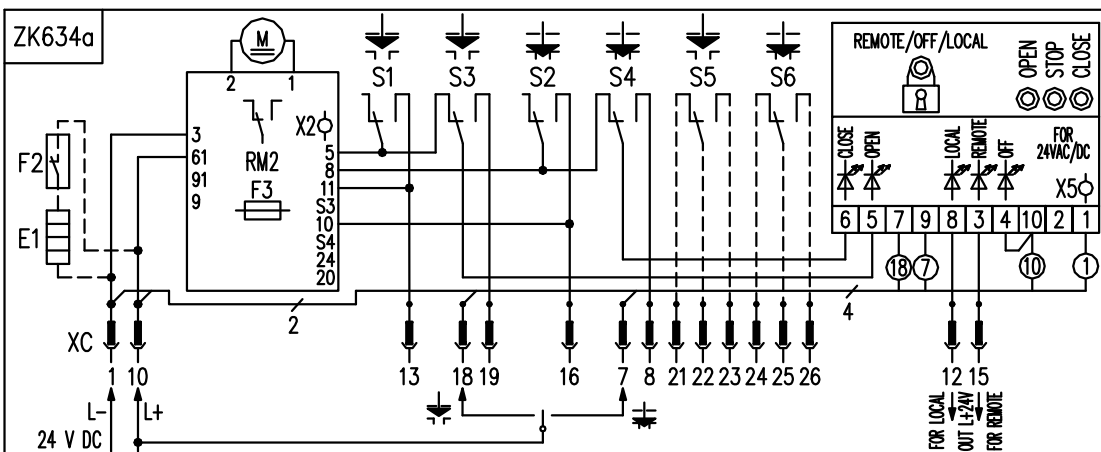
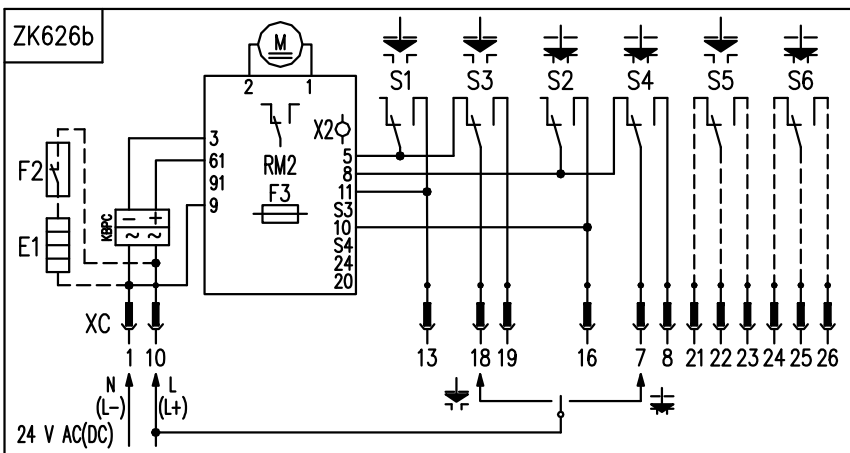
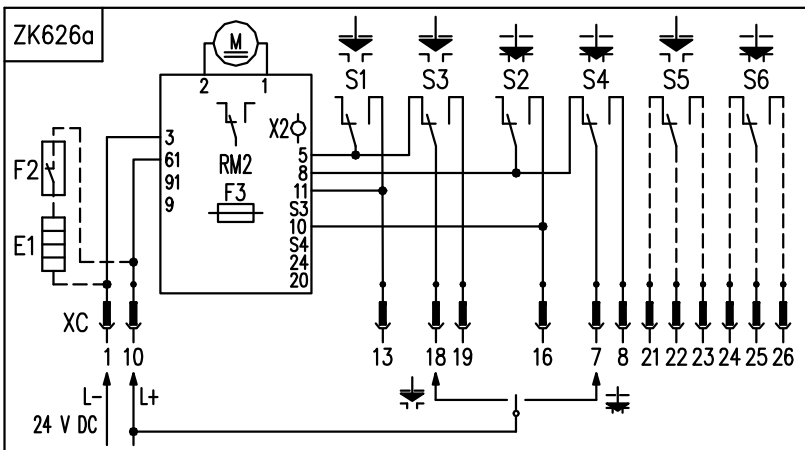

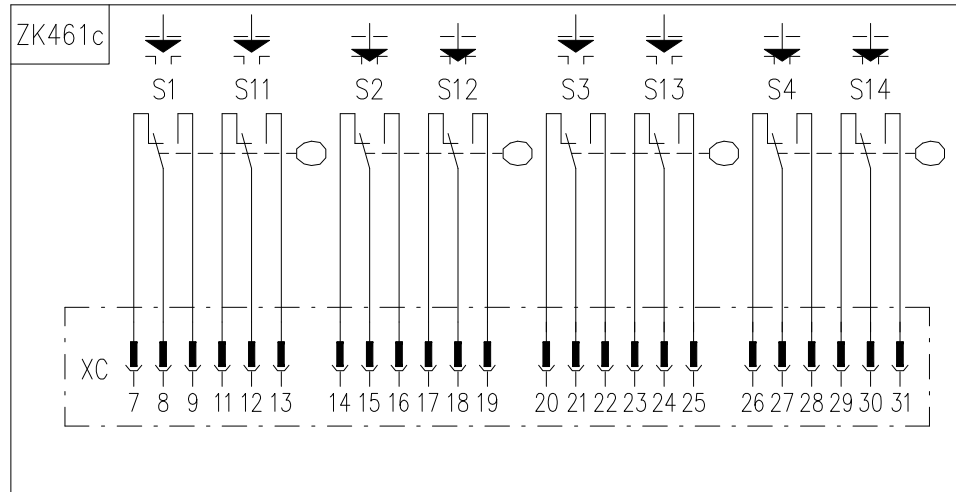
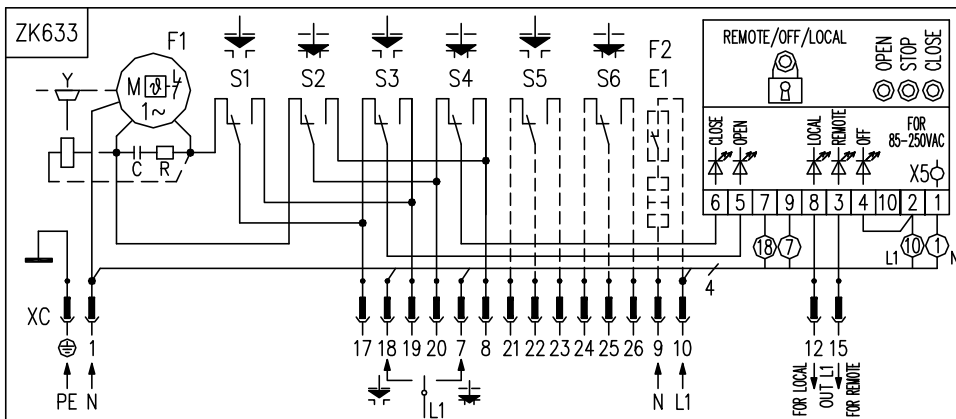
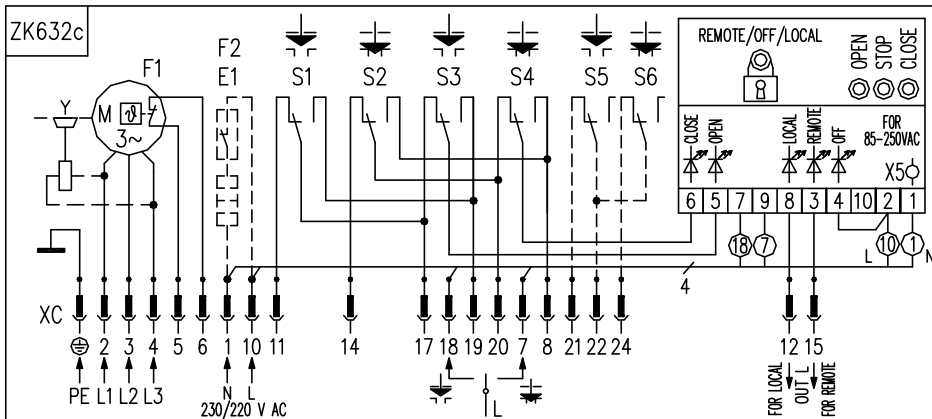
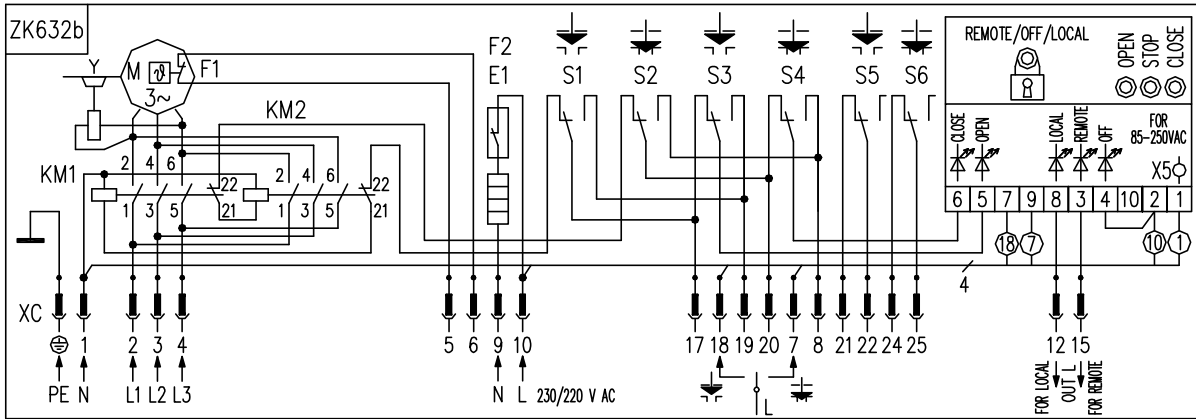

Wiring diagrams electric actuator SPR -- Electric connection to connector

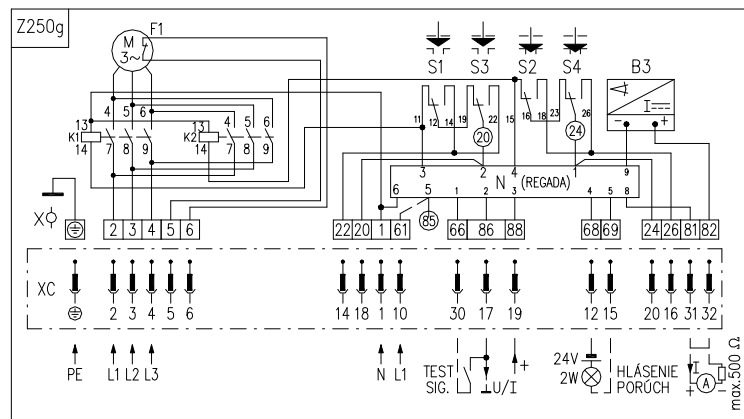
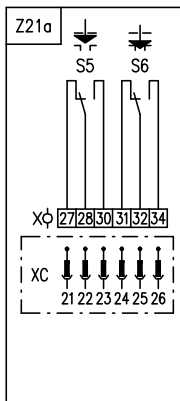
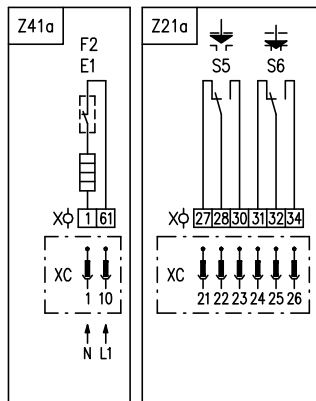
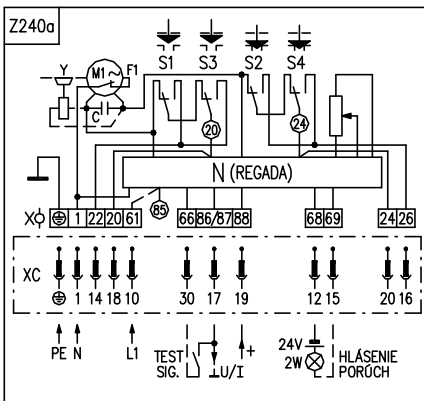
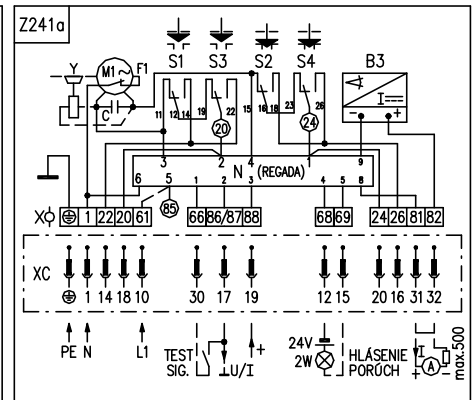
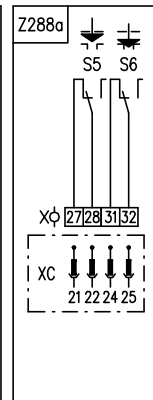
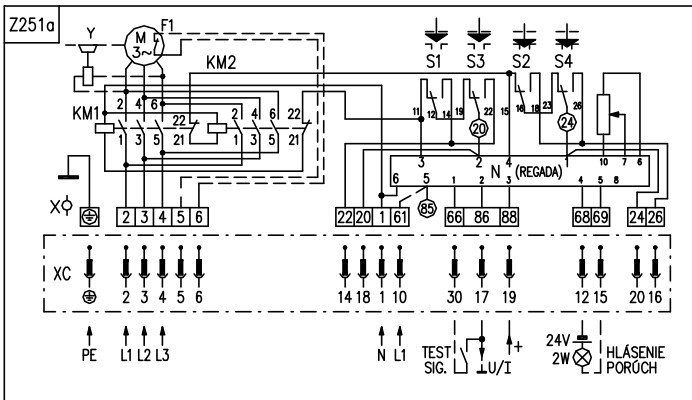
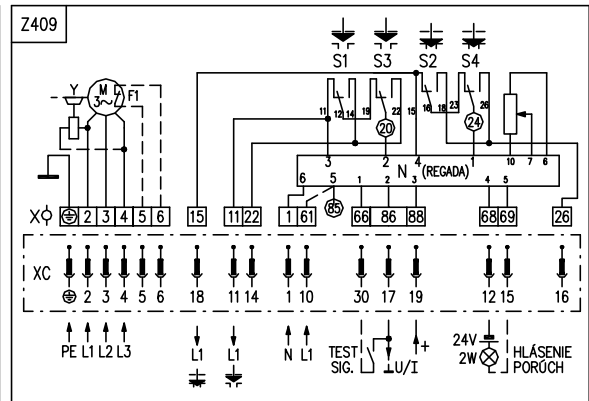
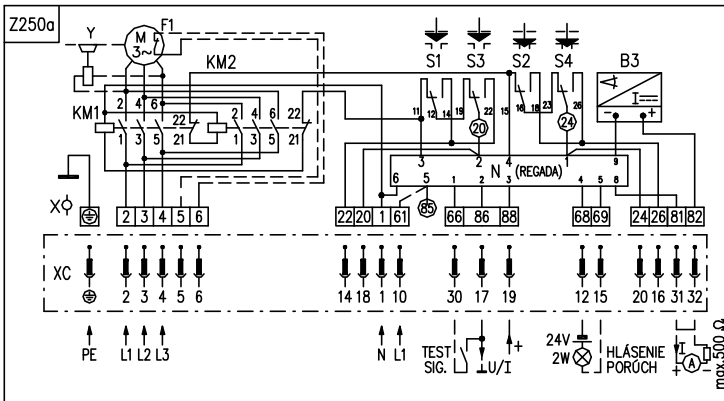

Wiring diagrams electric actuator SPR 2-SPR 2.4 — Electric connection to terminal board

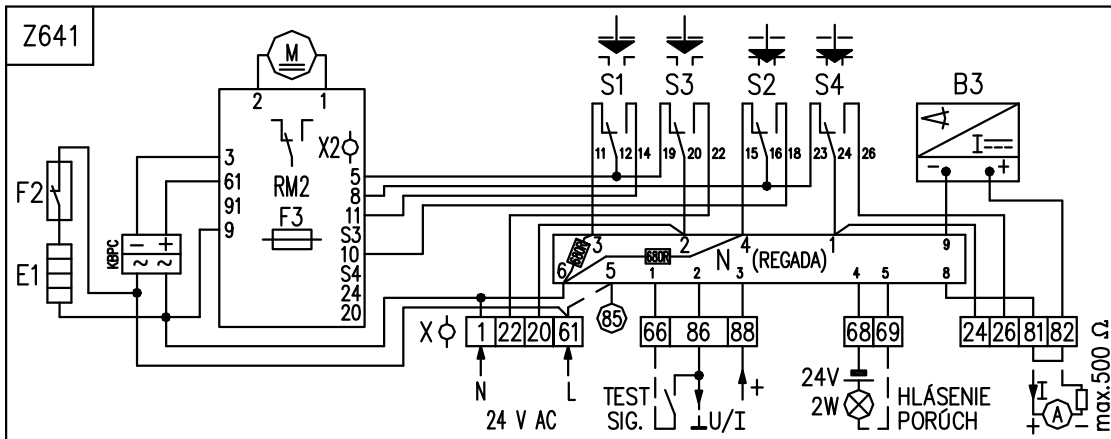
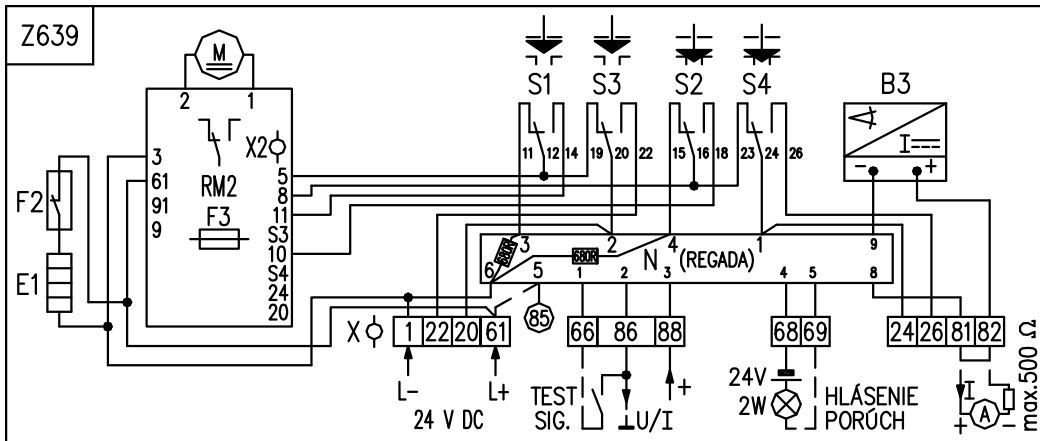
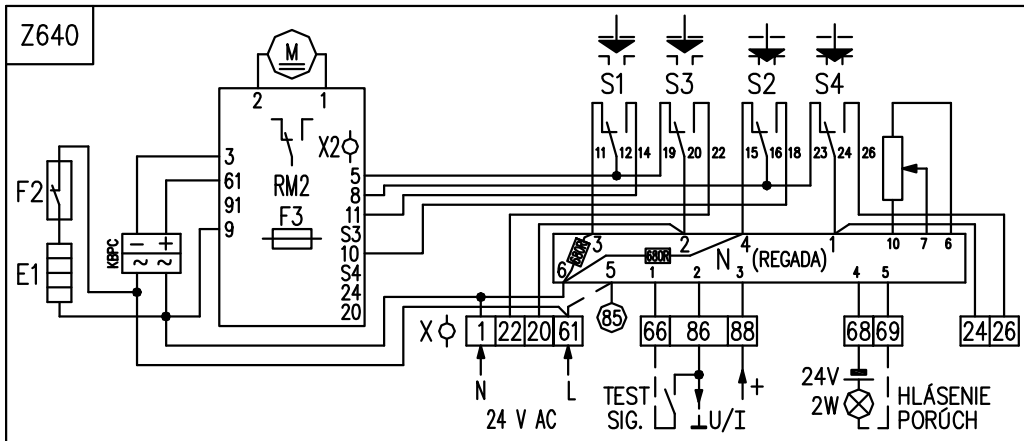
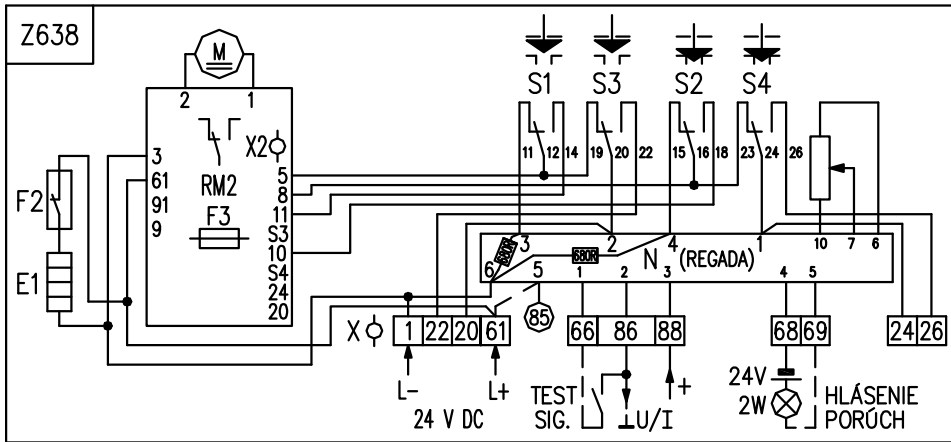

Wiring diagrams electric actuator SPR 2-SPR 2.4 — Electric connection to connector

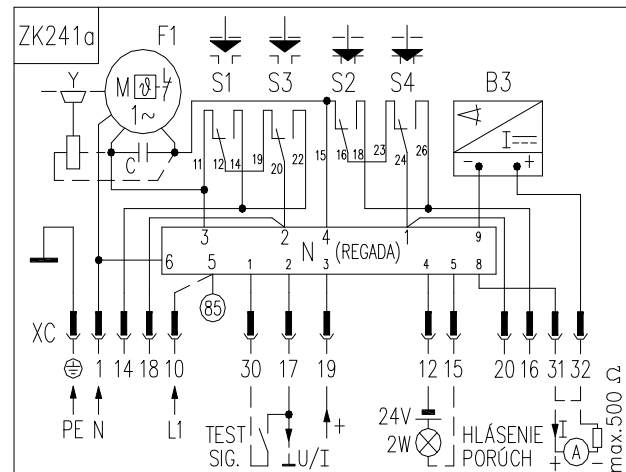
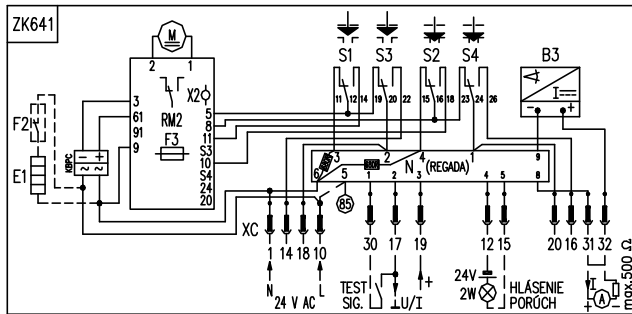
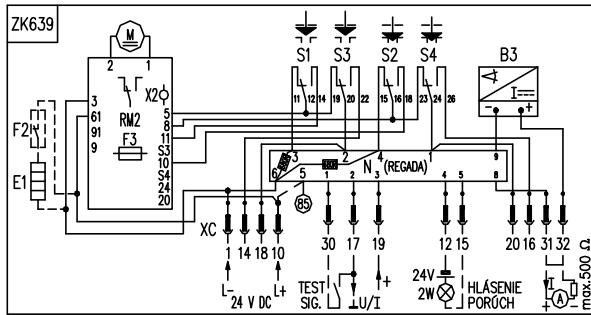
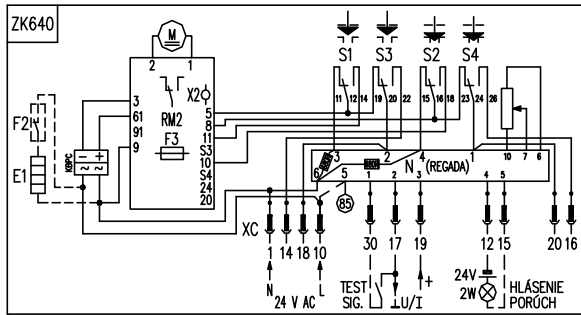
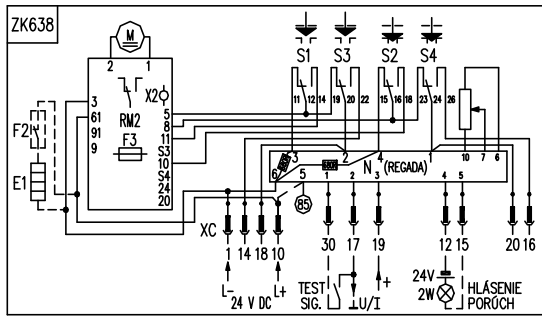

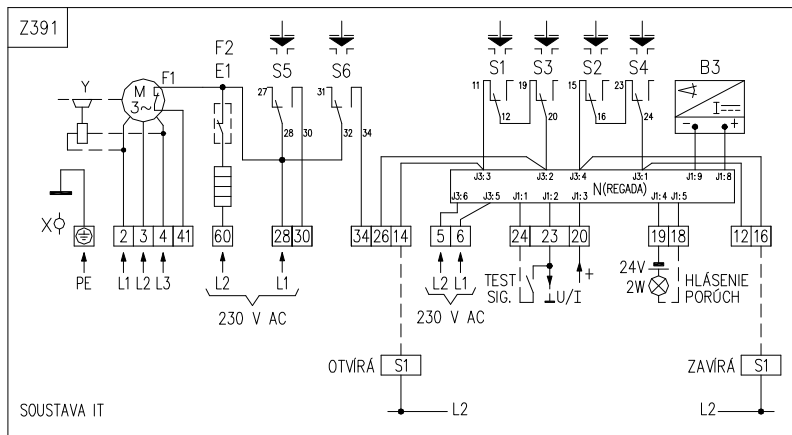
**Legend:**

- Z1a .....wiring diagram of 1-phase motor  
 Z5a .....wiring diagram of single resistant transmitter  
 Z6a .....wiring diagram of double resistant transmitter  
 Z10a .....wiring diagram of resistive with current converter or capacitive transmitter - 2-wire without supply  
 Z11a .....wiring diagram of position switches for 1-phase electric motor  
 Z12a .....wiring diagram of switches for 3-phase electric motor  
 Z21a .....wiring diagram of additional position switches connection for SPR  
 Z41a .....wiring diagram of space heater and space heater's thermal switch connection for SPR  
 Z78a .....wiring diagram of 3-phase electric motor  
 Z632c,ZK632c.....wiring diagram of 3-phase electric motor with electric local control  
 Z633,ZK633.....connection of 1-phase electric motor with local control  
 Z632b,ZK632b..wiring diagram of 3-phase electric motor with reverse contactors and electric local control  
 Z240a .....wiring diagram of SPR with controller with resistant feedback for 1-phase electric motor  
 Z241a,ZK241a wiring diagram SPR with controller with current feedback for 1-phase electric motor  
 Z250a,Z250g....wiring diagram SPR with controller with current feedback for 3-phase electric motor  
 Z251a .....wiring diagram of SPR with controller with resistant feedback for 3-phase electric motor  
 Z257a .....wiring diagram of resistive transmitter with current converter -3-wire version without power supply  
 Z260a, Z260f ...wiring diagram of resistive transmitter with current converter -3-wire version with power supply  
 Z269a .....wiring diagram of resistive transmitter with current converter or capacitive transmitter -2-wire version with power supply  
 Z288a .....wiring diagram of additional position switches for SPR for 3-phase electric motor  
 Z303 .....wiring diagram of 3-phase electric motor with reverse contactors  
 Z341 .....wiring diagram of double torque switch  
 Z378 .....wiring diagram of resistive with current converter or capacitive transmitter 2 and 3 - wire with supply  
 Z391 .....wiring diagram of 3-phase electric motor with controller and with current feedback, with power supply 3x500 V  
 Z404t .....connection of 1-phase electric motor and space heater's thermal switch  
 Z626a,ZK626a....connection of EA SP with electric motor 24 V DC  
 Z634a,ZK634a....connection of EA SP with electric motor 24 V DC and with local control  
 Z626b,ZK626b....connection of EA SP with electric motor 24 V AC  
 Z634b,ZK634b....connection of EA SP with electric motor 24 V AC and with local control  
 Z638, ZK638 ....connection of SPR with controller and resistant feedback for electric motor 24 V DC  
 Z639, ZK639 .....connection of SPR with controller and current feedback for electric motor 24 V DC  
 Z640, ZK640 .....connection of SPR with controller and resistant feedback for electric motor 24 V AC  
 Z641, ZK641 ....connection of SPR with controller and current feedback for electric motor 24 V AC  
 Z409 .....wiring diagram of SPR 1 up to SPR 2.4 with controller and resistant feedback for electric motor 3x400 V AC, without reverse contactors  
 Z594d .....EA with cable out of EA
- B1 ..... single resistant transmitter  
 B2 ..... double resistant transmitter  
 B3 ..... capacitive transmitter, or el. position transmitter  
 C ..... capacitor  
 E1 ..... space heater  
 F1 ..... electric motor thermal protection  
 F2 ..... space heater thermal switch  
 I/U ..... input (output) current (voltage) signals  
 M ..... electric motor  
 H1 ..... indication of "open" limit position  
 H2 ..... indication of "closed" limit position  
 H3 ..... indication of "electric local control"  
 M ..... electric motor

N.....	position controller	S3.....	position switch "open"
R.....	resistor	S4.....	position switch "closed"
SA1 .....	rotary switch with key "remote-0-electric local" control	S5.....	additional position switch "open"
SA2 .....	rotary switch "open-stop-closing"	S6.....	additional position switch "closed"
S1.....	torque switch "open"	KM1, KM2 .....	reverse contactor
S11 .....	double torque switch "open"	R <sub>L</sub> .....	voltage-dropping resistor
S2.....	torque switch "closed"	X.....	terminal board
S22 .....	double switch "closed"	XC .....	connector
		Y.....	brake of electric motor

Notes:

1. In case, that output signal from the capacitive transmitter (wiring diagram Z241a) is not used (incomplete circuit between terminal 81 and 82), it is required to connect terminals 81 and 82 by jumper (jumper is connected at manufacturing plant for connecting to terminal board only). By using output current signal from capacitive transmitter it is needed to remove jumper.
2. For the EA version with feeding voltage 24 V AC is not needed to connect ground wire PE.
3. In the version equipped with the controller device while using the feedback from transducer CPT; when using the output signal there has been no galvanic isolation of the signal from the input one!
4. In case that galvanically separated output signal is needed it is necessary to use galvanical separation element (is not part of delivery), e.g. NMLSG.U07/B (producer SAMO Automation s.r.o.). After discussion this module could be supplied by EA producer.

7.2 Dimensional drawings

P-1147 Flange ISO 5211

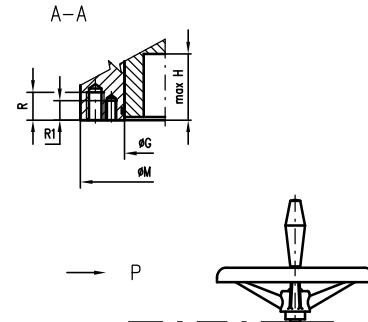
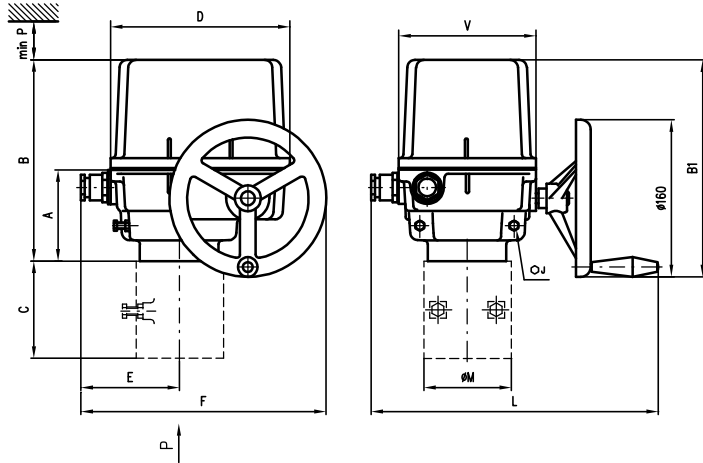

Hlavné rozmery / Main dimensions

Typ / Type	A	B	B1	C	D	E	F	J	L	M	P	V
SP 1	102	221	229	-	183	93	243	17	280 396*	90	160	140
SP 2								17		90		
SP 2.3	117	316	323	112	232	119	294	22	330 446*	125	210	190
SP 2.4				127				22		150		

\* platí pre vyhotovenie s konektorom / valid for version with a connector

Rozmery príruby / Flange dimensions

Typ / Type	G	H	R	R1	S	S1	T	T1	Velkosť príruby / Flange size
SP 1	40	37	16	14	70	50	M8	M6	F07 / F05
SP 2	40	49	18	14	70	50	M8	M6	F07 / F05
SP 2.3	55	56	25	17	102	70	M10	M8	F10 / F07
SP 2.4	65	71	30	25	125	102	M12	M10	F12 / F10

OTVORENÉ  
OPEN

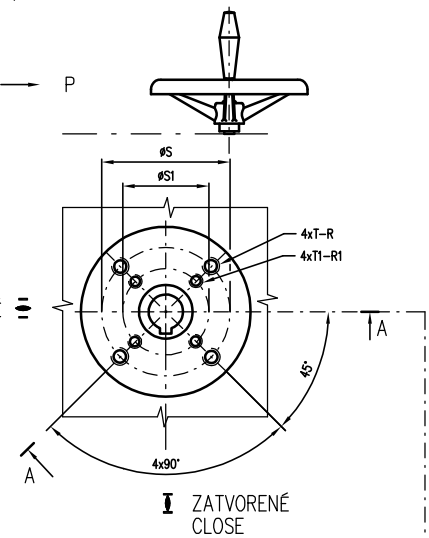

ZATVORENÉ  
CLOSE

Tvar pripojovacieho diela / Coupling shape

D-xx		L-xx		H-xx		V-xx		V-30, V-45.4		
ISO	Rozmer / Dimension	ISO	Rozmer / Dimension	ISO	Rozmer / Dimension	ISO	Rozmer / Dimension			
D-xx	U	L-xx	U	H-xx	U	V	V-xx	W	Z	X
D-14	14	L-14	14	H-14	14	22	V-20	20.0	22.5	6.0
D-17	17	L-17	17	H-11	11	18	V-22	22.0	24.5	6.0
D-22	22	L-22	22	H-8	8	13	V-32.2	32.2	35	6.5
D-27	27	L-27	27	H-17	17	25	V-17	17.0	19.5	6.0
D-11	11	L-11	11	H-13	13	19	V-28	28.0	30.9	8.0
D-16	16	L-16	16	H-22	22	32	V-42	42.0	45.1	12.0
				H-16	16	22	V-45.4	45.4	48.8	10.0
				H-27	27	48	V-50	50.0	53.5	14.0
				H-19	19	28	V-18	18.0	20.5	6.0
				H-10	10	16	V-30	30.0	32.5	8.0



P-1162 Stand + large lever

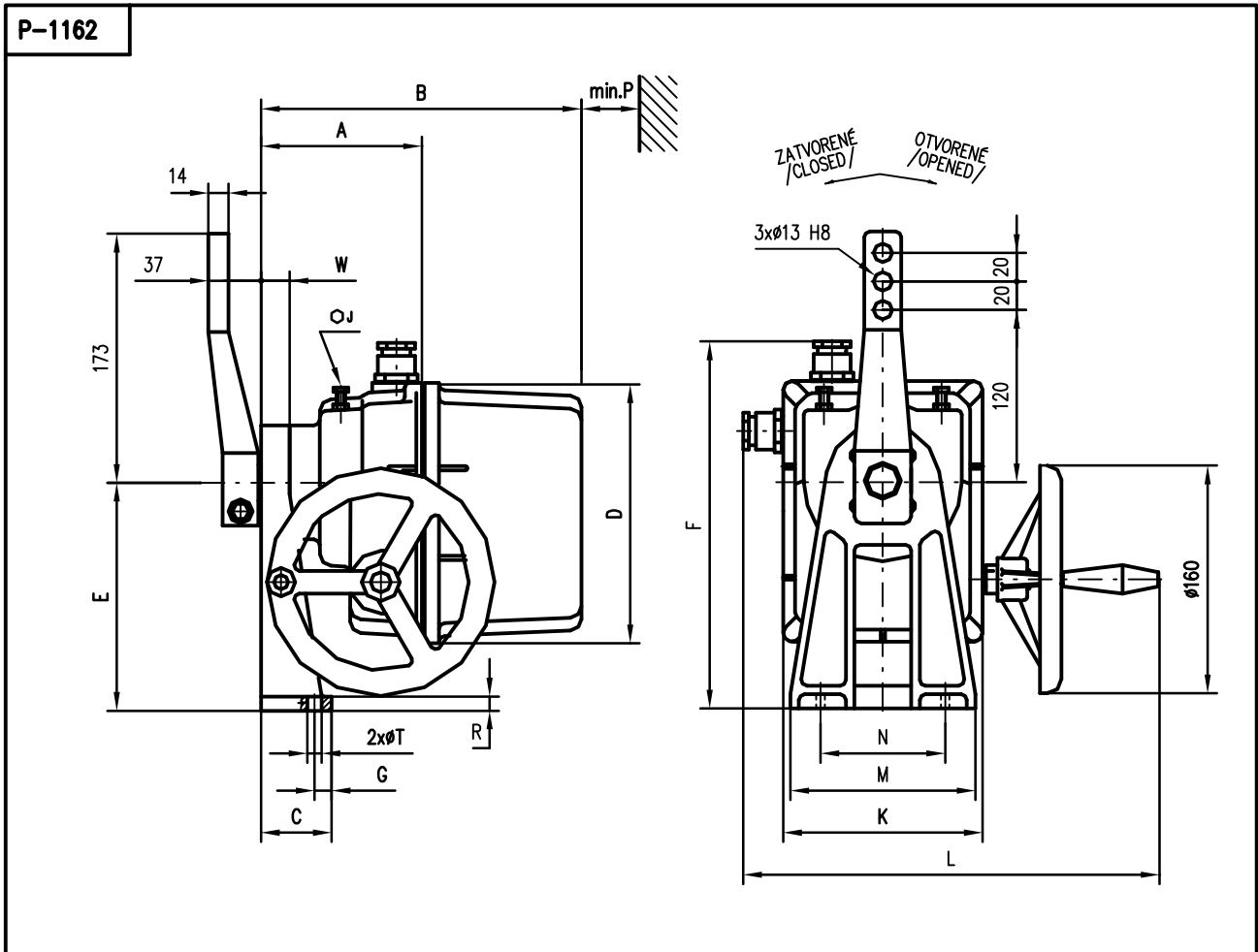

Hlavné rozmery / Main dimensions

Typ / Type	A	B	C	D	E	F	G	W	J	K	L	M	N	P	R	T
SP 1	122	243	50	183	160	258	12	20	17	140	280 396*	130	80	160	10	10.5
SP 2	145	344	58	232	200	323	30	28	17	190	330 446*	160	90	210	11	12.6

\* platí pre vyhotovenie s konektorom / valid for version with a connector

Tvar pripojovacieho dielca / Coupling shape /

Typ / Type	H	S	U	V	Z	Y	Y1	Tvar pripojovacieho dielca / Coupling shape/
SP 1	24.5	22	6	28	25	2	2	E01
SP 2	27.9	25	8	35	28	2	2	E02

P-1225 EA with electric local control

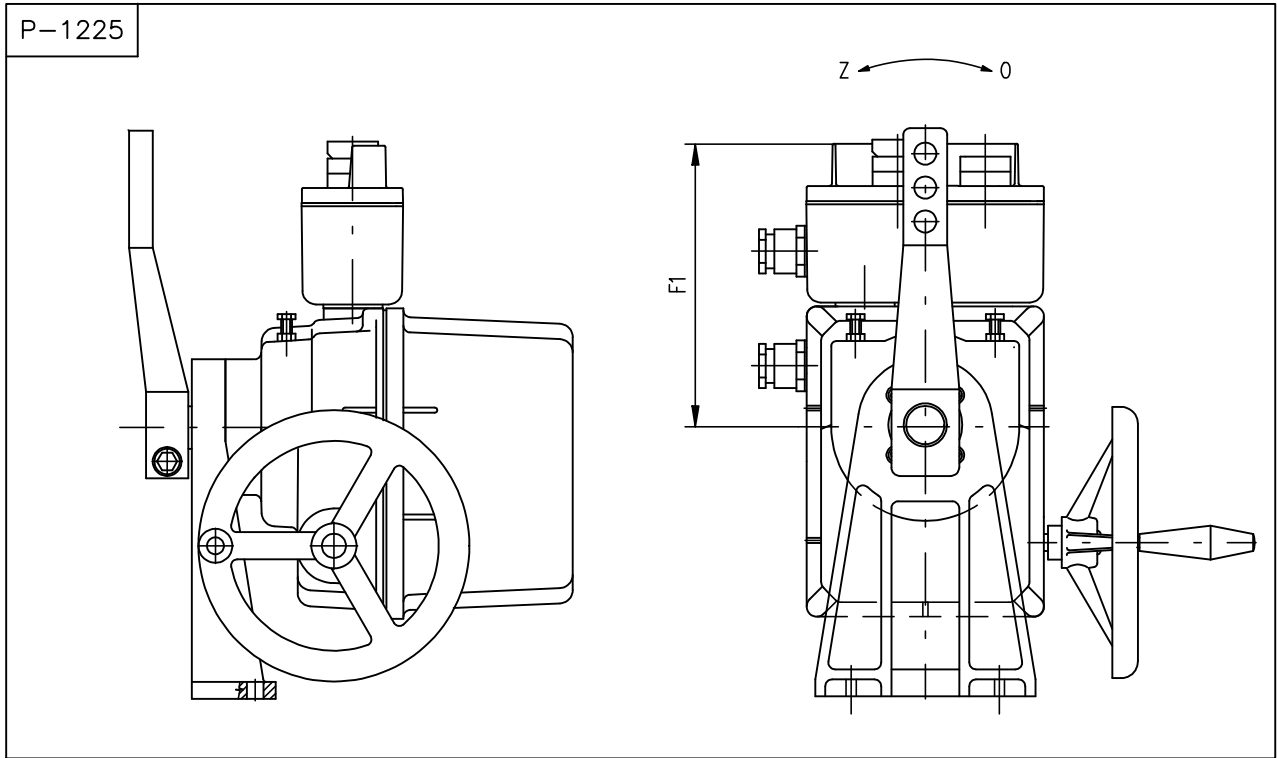

**DIMENSIONS OF STAND + LARGE LEVER VERSION:**

Type	Drawings	A	B	C	D	E	F	F1	F2	G	G1	H	W	J	K	L	M	N	P	R	S	T	V	Z
SP 1 SPR 1	P-1162, P-1225,	123	233	50	183	160	258 330*	169	273 345*	12	-	-	20	13	140	276 290*	130	80	160	10	-	10,5	-	-
SP 2 SPR 2		132	288	58	232	200	323 403*	194	-	30	-	-	28	17	190	326 351*	160	90	210	11	-	12,6	-	-
SP 2.3 SPR 2.4	P-1395, P-1412	-	-	135	-	160	297 377*	194	-	35	80	273	532	-	190	326 351*	170	120	-	-	20	13	60	25
SP 2.4 SPR 2.4		-	-	200	-	220	297 377*	194	-	60	120	278	593	-	190	326 351*	228	170	-	-	25	17	80	30

\* Note: \* - These dimensions are valid for versions with connector.

**COUPLING SHAPE:**

Shape Exx		Type	H	S	U	V	Z	Y	Y1	Coupling shape
	SP 1/SPR 1	24,5	22	6	28	25	2	2	E01	
	SP 2/SPR 2	27,9	25	8	35	28	2	2	E02	
	SP 2.3/SPR 2.3	43,1	40	12	66	56	4	7	E03	
	SP 2.4/SPR 2.4	53,8	50	16	82	70	4	7	E04	

P-0210 Pull-rod TV360

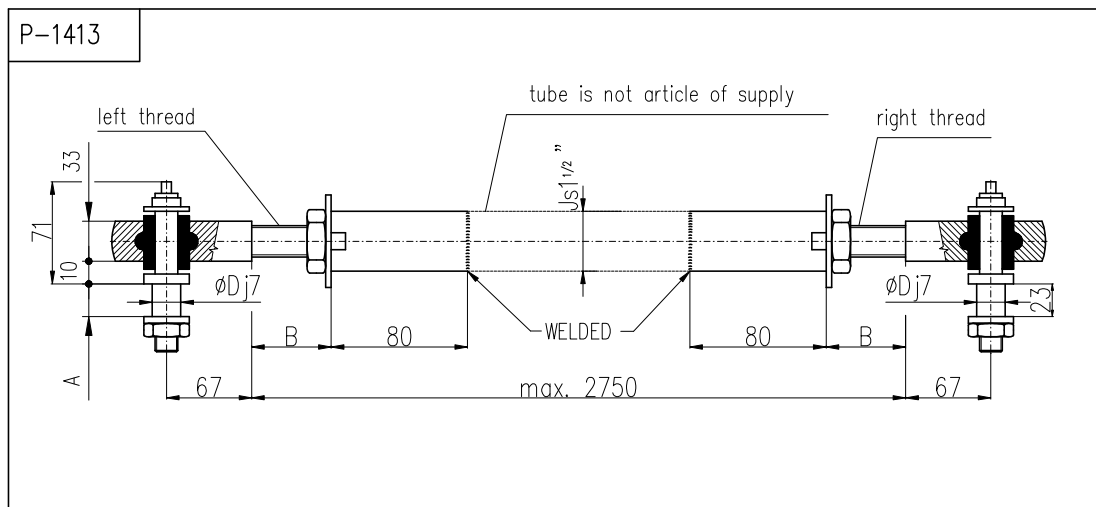
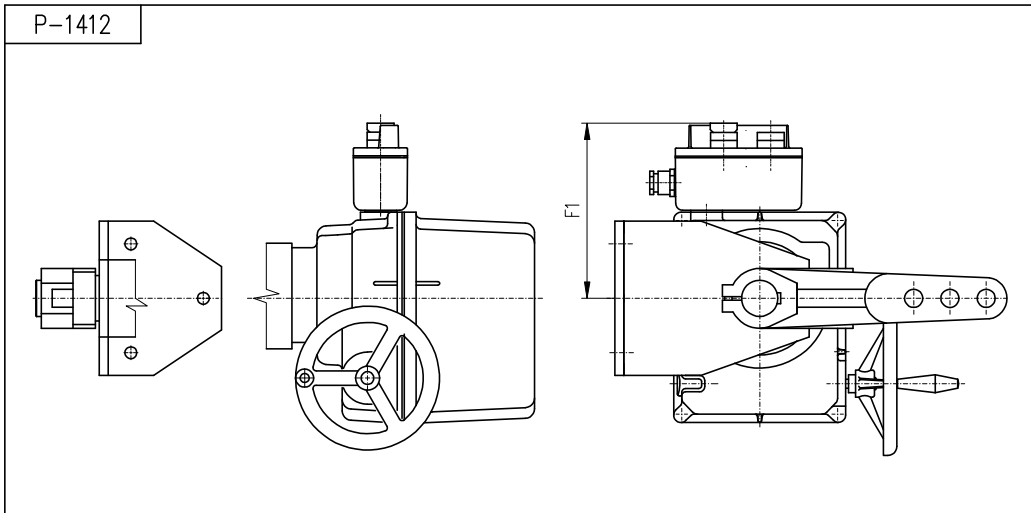
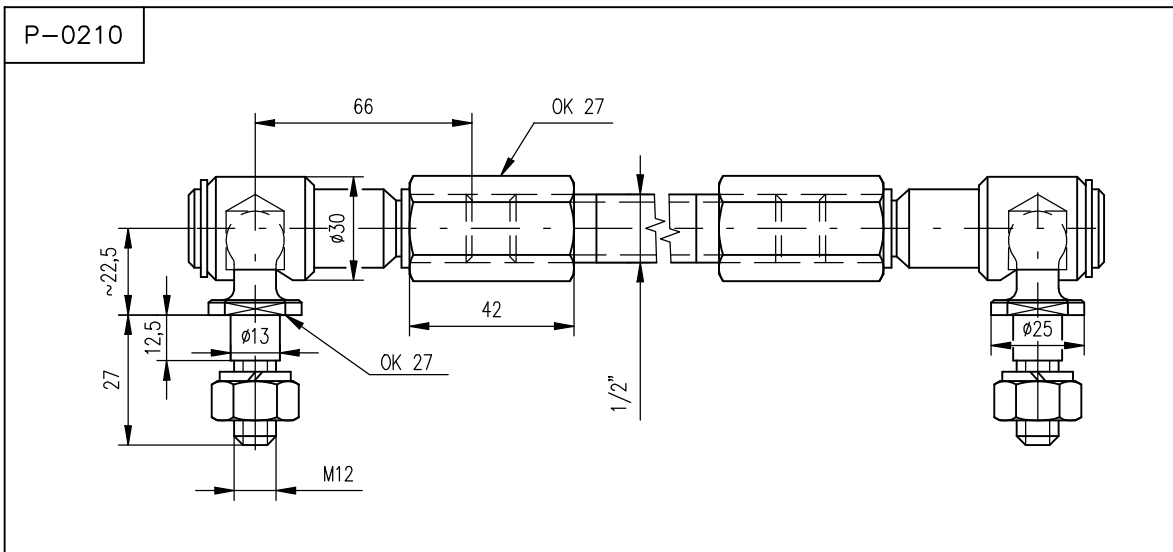

Version	Pull-rod version	A	B	D
P-1413/A	TV 40-1/20	23	Max.50	20
P-1413/B	TV 50-1/25	28	Min. 30	25

## P-1222 EA with electric local control

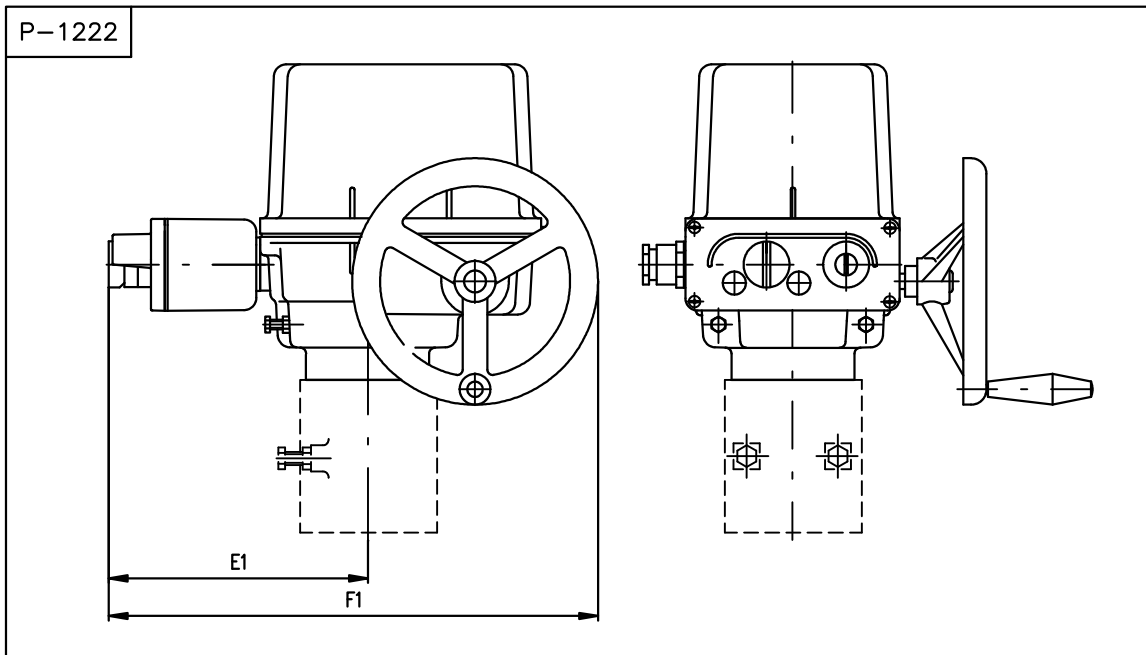

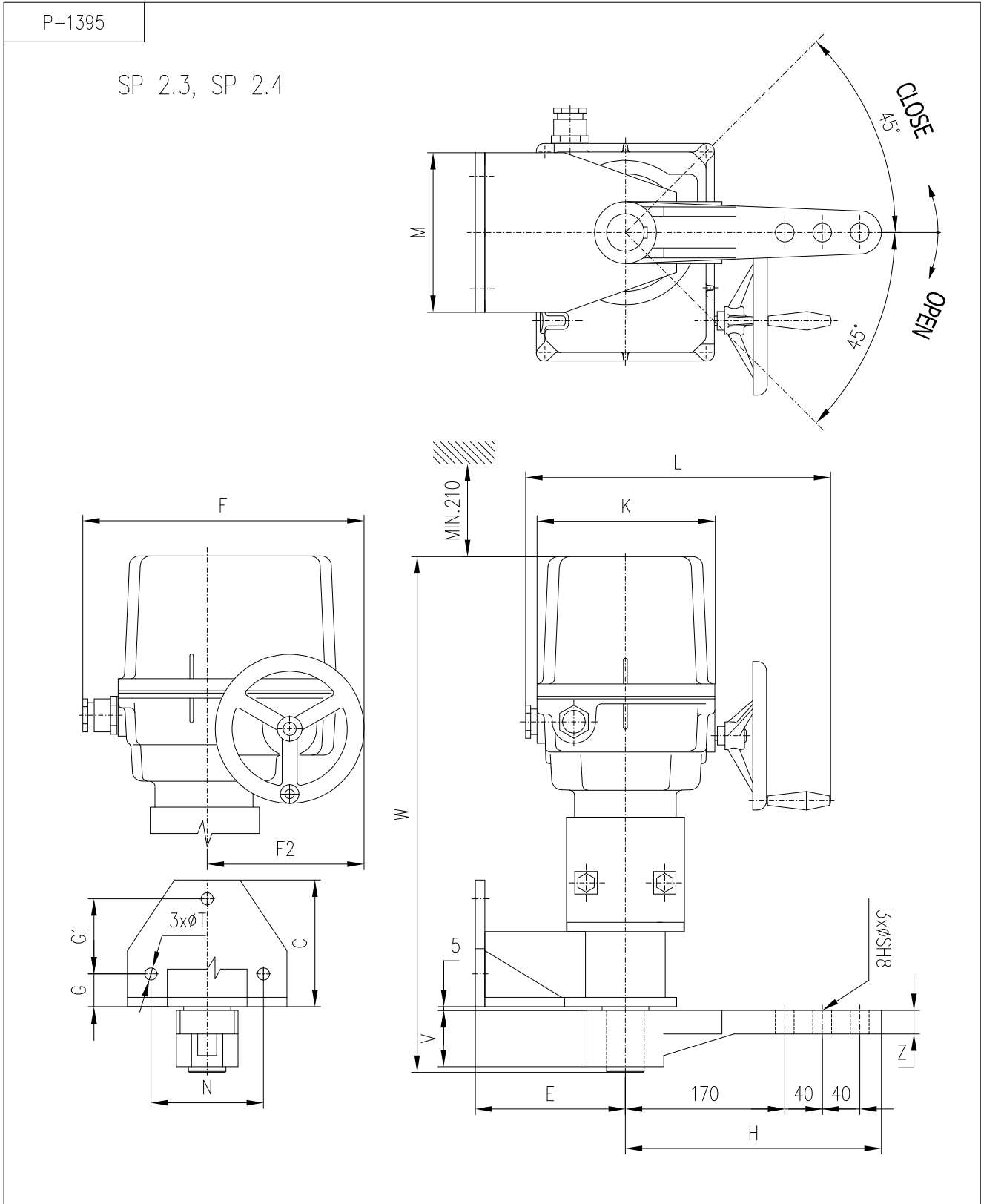

TYP	C	E	F	F2	G	G1	H	W	K	L	M	N	S	T	V	Z
SPx 2.3xx	135	160	294	175	35	80	278	584	190	330 446*	170	120	20	13	55.5	20
SPx 2.4xx	200	220	294	175	60	120	278	654	190	330 446*	228	170	25	17	80	30

**Commercial representation**  
***Slovak Republic:***

**Regada, s.r.o.,**  
Strojnícka 7,  
080 01 Prešov  
Tel.: +421 (0)51 7480 460,  
Fax: +421 (0)51 7732 096,  
E-mail: [regada@regada.sk](mailto:regada@regada.sk)