



INSTALLATION, SERVICE AND MAINTENANCE INSTRUCTIONS



***Electric multi-turn actuators Rematic
with the DMS3 M1, DMS3 M2, DMS3 P1,
DMS3 P2 electronic control UMR 1PA, UMR 2PA***

TEST CERTIFICATE

ELECTRIC MULTI-TURN ACTUATOR UMR 1PA, UMR 2PA	
Type number	Power supply V Hz
Serial number	Max. load torque Nm
Production year	Switching-off torque Nm
Wiring diagram	Operating speed min ⁻¹
.....	Adjusted number of revolutions
.....	Control
.....	Input operation signal
Warranty period months	Output signal.....
Serial number of electric motor	
Serial number of control unit	
Tests made by	Packed by
Date	Signature and stamp

COMPLETENESS CERTIFICATE

Used valve	
Assembled by: Firm	
Name.....	
Warranty period months	
Date	Signature and stamp.....

INSTALLATION CERTIFICATE

Location	
Installed by: Firm	
Name	
Warranty period..... months	
Date	Signature and stamp.....

Please read these instructions carefully before mounting and operating the actuator!

Contents

1. General data	2
1.1 Purpose and applications	2
1.2 Safety instructions	2
1.3 Instructions for staff training	2
1.4 Data specified on electric actuator	3
1.5 Warranty conditions	4
1.6 Under-guarantee and after-guarantee service	4
1.7 Operation conditions	4
1.8 Packing, transport, storing and unpacking	6
1.9 Assessment of the product and packaging and removal of contamination	7
2. Description, function and specifications	8
2.1 Description and function	8
2.2 Basic specifications	12
3. Installation and dismantling of actuator	23
3.1 Installation	23
3.2 Dismantling	24
4. Adjusting of actuator	25
4.1 EA control set-up options (regulating)	28
4.2 Procedure for setting individual parameters and the register of errors and warnings	30
4.3 Putting an EA into operation when the EA is set up and connected with the armature already in the production plant (starting the calibration)	33
4.4 Putting an EA into operation when the stroke and parameter setting done by the producer suit to your needs	33
4.5 Putting an EA into operation when it is necessary to do a change to the stroke (setting new end positions), and the other parameter setting done by the producer suits to your needs	33
4.6 Setting other parameters	34
4.7 Error messages from the control unit	34
5. Service and Maintenance	35
5.1 Service	35
5.2 Maintenance - extent and periodicity	36
5.3 Troubleshooting	36
6. Accessories and Spare Parts	38
6.1 List of the Spare Parts	38
7. Enclosures	39
7.1 Wiring diagrams	39
7.2 Dimensional drawings	64
7.3 Guarantee service check report	67
7.4 Post guarantee service check report	68
7.5 Commercial representation	69

The Installation, Service and Maintenance Instructions are drawn up according to requirements of EC Executive Nr. 2006/42/EC "Uniform requirements for machines and devices from the point of view of safety and health care", to save life and health of users and to avoid material damages and exposure environment to danger

1. General data

1.1 Purpose and applications

Explosion - proof electric multi-turn actuators **Rematic** (hereinafter referred as EA only) with the DMS 3 electronic control of the **UMR 1PA, UMR 2PA** (hereinafter referred as **UMR XPA** only) are set up by the program to be controlled on the 24 V DC voltage level; are set up by the program to be controlled by analogue input signal, potentially controlled through a interface with Modbus/Profibus communication protocol.

EA UMR XPA types are high-powered electric-mechanical products designed for direct installations onto controlled devices (regulating bodies - valves, etc.). EA are provided for remote control of closing bodies or automotive control of regulating bodies in both directions of their movement. They can be equipped with means of measuring and control of technological processes where an unified analogue direct current resp. voltage signal is an information bearer on their input and/or output (not valid for EA's with Modbus/Profibus protocol). They can be used in heating, energy, gas, air-conditioning and other technological systems, which they are suitable for, regarding their features. They are connected with controlled devices with a flange and coupling shape according to ISO 5210, DIN 3338, or in accordance with GOST R 55510-2013.



1. *It is forbidden to use EA as a lifting mechanism!*

1.2 Safety instructions

Characteristics of the Product Regarding Its Exposure Rate



EA are reserved technical devices with higher rate of danger (group A), with possibility of installation in areas specially danger regarding casualties caused by electric current.

Electric actuators are according to directive LVD 2014/35/EU and standard EN 61010-1+A1 in the edition in terms of valid certificate, assigned for installation category II (overvoltage category), pollution degree 2.

The product meets the essential safety requirements according to EN 60204-1 and is in compliance with EN 55011/A1 within valid edition.

Product influence to environment

Electromagnetic compatibility (EMC): the product complies with the requirements of the Directive 2014/30/EU of the European Parliament and of the Council on the approximation of the laws the Member States relating to the electromagnetic compatibility and with the requirements of standards as well EN IEC 61000-6-3, EN IEC 61000-6-2, EN IEC 61000-3-2+A1 and EN 61000-3-3+A1, in the edition in terms of valid certificate.

Vibrations caused by the product: product influence is negligible.

Noise produced by the product: The maximum allowable noise level (A) of the product measured in a place of operation is 78 dB (A).

1.3 Instructions for staff training

Requirements for professional qualification of people performing installation, service and maintenance



The electrical connection of the actuator can only be carried out by a person in accordance with legislative requirements of the given country, depending on the required areas of location/use. Service can be performed only by workers professionally qualified and trained by the producer or contracted service centre.

Warning for safety use



1. Products are assigned for operation in environment consist of gas, steam and vapours, with temperature range: -25°C to $+55^{\circ}\text{C}$ or -50°C to $+40^{\circ}\text{C}$ or -60°C to $+40^{\circ}\text{C}$, with pressure range from 0.8 to 1.1 bar.

2. If the actuator is placed on device which regulate medium with higher temperature than +55°C, protect the actuator by additional construction in order to maintain ambient temperature max. +55°C and also to stop temperature transmitting through junction component!
3. Cable glands blinds are assigned only for transport and storage period, i.e. for period till the actuator is builded into operation, than blinds must be replace by connecting cable.
4. In case of not using one of the cable gland, it has to be replaced with a suitable blinding plug.
5. Temperature at the point where the cables enter the actuator can reach max. 90°C. When choosing the connection cables for the actuator, it is therefore necessary to consider this temperature as well.
6. **WARNING !** If it is necessary to operate electric actuator at a temperature of -50°C to -60°C, which has been disconnected from the electrical network, it is necessary to heat the interior of the actuator for 2 hours before applying voltage to the electronics. We start this heating by connecting the supply voltage to terminals "U" and "N" (for EA with DMS3), or to terminal "20" and "N" (for EA with Modbus or Profibus communication protocol), for a period of 2 hours. After two hours of heating, the EA is ready to connect the voltage to the electronics, including the other terminals of the electronics according to the specific wiring diagram. Do not disconnect the heating supply voltage, leave it permanently connected. With this design of the actuator, the temperature of the internal space in the control box is controlled by the thermal switch (F2) and not the electronics of the actuator.

Warning for safety use

Product protection

EA UMR XPA does not have own short-circuit protection, therefore there must be included suitable protective device into the supply power (circuit breaker, or fuse), which serves at the same time as main switch. For protection, we recommend to use a fuse type "T" or a contactor type "C".

Supply voltage of 24 V AC/DC ES is provided with its own protection of the DC electric motor supply circuits and it is not provided with protection of the heating resistor circuit against short circuit.

Type of equipment from a connection point of view: The equipment is designed for permanent connection.

1.4 Data specified on electric actuator

Nameplate:

Warning plate:

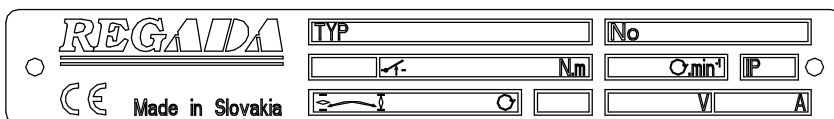

Nameplate contains the basic data concerning identification, performance and electricity: indication of producer, type, serial number, max. load torque and switching-off torque, operating speed, protection code, number of revolution, supply voltage and current.

Graphic symbols on electric actuator

The graphic symbols used on electric actuator substitute the text messages. Some of them are in accordance with EN ISO 7010, ISO 7000 and IEC 60417 within valid edition.



Dangerous voltage

(EN ISO 7010-W012)

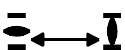

Stroke of the electric linear actuator



Switching-off torque



Manual control

(0096 ISO 7000)



Protection terminal

(5019 IEC 60417)

1.5 Warranty conditions

The supplier is responsible for completeness of the delivery and guarantees these specifications of the product which are stated in the Contract.

The supplier is not responsible for any deterioration of parameters caused by the customer during storage, unauthorised installation or improper operation.

1.6 Under-guarantee and after-guarantee service

Our customers are provided with professional service of our firm in installation, operation, service, maintenance, revision and help in troubleshooting for all our products.

Under-guarantee service is performed by the service department of the production plant, or by a contracted service centre according to a written claim.

In case of occurring of any fault please let us know it and state:

- type code
- serial number
- ambient parameters (temperature, humidity...)
- duty cycle including frequency of switching
- type of switching-off (position or torque)
- set switching-off torque
- type of fault - description of claimed fault
- it is recommended to place also Installation certificate.

It is recommended to have **after-guarantee service** performed by the service department of the production plant, or by a contracted service centre, with national laws.

1.6.1 Lifetime of actuators

The lifetime of an electric actuator (EA) is at least 6 years.

EA used for closing mode (closing valves) comply with the requirements for at least **15,000 working cycles** (cycle C – O – C at 30 revolutions per operating stroke for multi-turn EA)

EA used for regulating/modulating operation (control valves) comply with the below stated numbers of **operating hours** at the total number of 1 million start-ups:

Switching frequency				
max. 1,200 [h ⁻¹]	1,000 [h ⁻¹]	500 [h ⁻¹]	250 [h ⁻¹]	125 [h ⁻¹]
Minimal lifetime expectancy – number of operating hours				
850	1,000	2,000	4,000	8,000

Time of **net operation** is min. 200 hours, max. 2,000 hours.

Lifetime at operating hours depends on loading and switching frequency.

Note : High switching frequency does not ensure better regulation. Setting of regulation parameters should be therefore made with the inevitably necessary switching frequency needed for the process in question

1.7 Operation conditions

1.7.1 Product location and operation position

- Electric actuators may be installed and operated in enclosed locations of industrial facilities with no temperature and moisture regulation, protected from direct climatic effects (such as direct sunlight). Moreover, special “marine” versions may be used in waste water treatment applications, water management, selected chemical applications, tropical environments and coastal areas.
- Electric actuators must be placed with access to the manual control wheel, to the upper cover and to cable glands resp. to local control.
- Installation and operation of actuators is possible in either position. Common position is the one with vertical position of exit part axis and control box above.



Warning:

Actuator installed on the open place must be protected against a direct climate effects by shelter.

In applications placed in an ambient of a relative moisture above 80%, in external ambient under shed, it is necessary to change the preset thermostat temperature +25°C to +70°C by a PC and program to prevent switching off the heating resistor.

1.7.2 Working enviroment

According to valid standard IEC 60 721-2-1, there are delivered these versions of electric actuators:

- 1) Version „**standard**“ for type climate temperate
- 2) Version „**tropical wet**“ for type climate tropical wet
- 3) Version „**cold**“ - for type climate cold
- 4) Version „**tropical dry and dry**“ for type climate tropical dry and dry
- 5) Version „**marine**“ for type climate marine
- 6) Version „**arctic**“ for type climate arctic.

In accordance with IEC 60 364-1, IEC 60 364-5-51 and IEC 60 364-5-55 within valid edition the EA have to resist external effects and operate reliably:

In the conditions of the following types of environment:

- warm mild to very hot dry with temperatures -25°C to +55°C AA 7*
- cold, warm mild to hot dry with temperatures -50°C to +40°C..... AA 8*
- cold, hot dry to slightly hot dry with temperatures -50°C to +55°C..... AA 8*+AA 7*
- cold to mild hot dry with temperatures in range -60°C až +40°C.....AA 1*+AA 5*
- with relative humidity 10÷100%, including condensation with maximum content 0,029kg of water in 1kg of dry air , with temperatures stated above..... AB 7*
- with relative humidity 15÷100%, including condensation with maximum content 0,036kg of water in 1kg of dry air , with temperatures stated above AB 8*
- with relative humidity 10÷100%, including condensation with maximum content 0,036 kg of water in 1kg of dry air, with temperatures stated above AB 8*+AB 7*
- with relative humidity 5 to 100 %, including the condensation of up to 0,025 kg water content per 1 kg of dry, at above stated temperatureAB 1*+AB 5*
- with elevation up to 2000 m, with barometric pressure range from 86 kPa up to 108 kPa AC 1*
- with exposure to intensive water jets (IPx6) AD 6*
- with shallow immersion – (protection enclosure IP x 7) AD 7*
- with strong dustiness – with a possibility of influences of inflammable, non-conducted and non-explosive dust; the middle layer of dust; the dust drop more than 350 but not more than 1000 mg/m² per day (products with protection enclosure of IP 6x)AE 6*
- expose to corroding or pollute chemical substances during producing or using of these substances); at places where is handled with small quantity of chemical products and these can accidentally get in contact with an electric device..... AF 3*
- with permanent exposure of big amount of corroding or contaminated chemical and salt fog in execution for sea environment, fog sewage water disposal plant and some chemical plant AF 4*
- with a possibility of influences of mechanical stress:
 - medium sinusoid vibrations with frequency in range from 10 up to 150 Hz, with shift amplitude of 0,15 mm for f<fp and acceleration amplitude 19,6 m/s² for f>fp (transition frequency fp is from 57 up to 62Hz)AH 2*
 - medium impacts, shocks and vibrations AG 2*
 - with serious danger of plants and mould growingAK 2*
 - with serious danger of animal occurrence (insects, birds, small animals) AL 2*
- with detrimental influence of radiation:
 - of stray current with intensity of magnetic field (direct or alternate, of mains frequency) up to 400A.m⁻¹AM2-2*
 - of sun radiation with intensity > 500 and ≤ 700W/m²..... AN 2*
- with effects of medium seismic activity with acceleration > 300 Gal ≤ 600 GalAP 3*
- with direct endanger by storm AQ 3*
- with quick air movement and strong wind AR 3 , AS 3*
- stand on a conductive bottom) BC 3*
- with a danger of inflammable gases and vapours explosion - for Ex of version BE 3N2*
- fire risksBE 2*

* Marking in accordance with IEC 60364-1, IEC 60 364-5-51 and IEC 60 364-5-55 within valid edition

1.7.3 Power supply and duty cycle

Power supply:

electric motor 120 resp. 110 V AC, 230 resp. 220 V AC, 3x400 resp. 3x380 V AC
 resp. 3x415 V AC resp. 3x460 V AC resp. 24 V AC/DC $\pm 10\%$, according to valid certificates
 Control..... binary inputs 24 V DC $\pm 10\%$
 input control signal 0/4/12 to 20 mA, 4 to 12 mA resp. 20 to 0/4/12 mA, 12 to 4 mA,
 or 0/2 to 10 V, resp. 10 to 0/2 V
 electronic positional transmitter (EPV) without power supply (passive)..... 18 up to 30 V DC $\pm 10\%$
 communication protocol (by version) Modbus (either single Channel or duo Channel)
 Profibus (either single Channel or duo Channel)
Power supply frequency.....50 Hz, or 60**Hz $\pm 2\%$

** Rotation speed will increase 1,2 times, and torque will decrease 0,8 times

Duty cycle (according to EN 60034-1 (IEC 60034-1) within valid edition):

EA UMR XPA designed for remote control are designed for :

- short-time operation **S2-10 min**
- intermitted operation **S4-25%, 6 up to 90 cycles per hour**

EA UMR XPA designed for **automatic regulation** via analogue signals are designed for :

- intermitted operation S4-25% with min. number of starts according to the following table:

Rated torque ranges [Nm]	On-Off [running time per hour] ^{a)}	Inching [start per hour] ^{b)}	Modulating with reverse contactors [starts per hour] ^{c)}
do 100	15	30	1200

a) Based on an average load of at least 30% on the rated torque with the ability to transmit 100% of the rated torque for at least 10% of the time.

b) For inching one start duration is defined by at least one revolution, with an average load of 30% of the rated torque.

c) For modulating, one start consist of at least $\frac{1}{4}$ revolution, with a load of at least 30% of the rated torque. The cyclic duration factor (i.e. the ratio between the rutting period and total period) shall be not less than 25% (e.g. 1s running and 3s resting).

1.8 Packing, transport, storing and unpacking

Surfaces without surface treatment are treated by conservation preparation MOGUL LV 2-3 before packaging .

Conservation is not necessary if the following storage conditions are complied with:

- Storage temperature: -10 to +70 °C
- Relative air humidity max.80 %
- Electric actuators and their accessories must be stored in dry, well ventilated covered spaces, protected against impurities, dust, soil humidity (by placement to racks, or on palletes), chemicals and foreign interventions
- There shall be no corrosive gases present in the storage areas.

The of UMR XPA are delivered in solid packages guaranteeing resistance in accordance with EN/IEC 60 654.

Package is a box. Products in boxes is possible to load on the pallets (pallet is returnable). On the outer side of the package is stated:

- manufacturer label,
- name and type of product,
- number of pieces,
- other data – notices and stickers.

The forwarder is obliged to secure packed products, loaded on transportation means, against self-motion; if open transportation means are used, to secure their protection against atmospheric precipitations and splashing water. Displacement and securing of products in transportation means must provide their stable position, exclude the possibility of their inter-collision and their collision with the vehicle walls.

Transportation can be executed by heatless and non hermetic spaces of transportation vehicles with influences within the range:

- temperature: -25° C up to +70°C (a strange version –50 ° C up to +45 ° C)
- humidity: 5 up to 100 %, with max. water content 0.028 kg/kg of dry air
- barometric pressure 86 up to 108 kPa

After receiving EA check whether during transport or storage the actuator was not damaged. Compare also whether the parameters on their nameplates are in accordance with accompanying documentation or the Contract. If any discrepancy or fault occur inform immediately your supplier.

If the actuators and accessories are not immediately installed, they have to be stored in dry, well-ventilated sheltered rooms, protected against dirt, dust, soil humidity (with placing onto shelves or onto pallets), chemical impacts and encroachment, at ambient temperature from -10°C up to +50 °C and relative humidity max. 80 %, in special version at temperature –50°C do +40°C.

- It is forbidden to store EA outside or in areas not prevented against direct impact of climate.
- Strains of the surface finishing should be promptly removed if any – it can prevent the product against corrosion damages.
- While storing more than one year it is necessary to check lubrication filling before the actuator is put into operation.
- The EA installed but not operated are to be protected the same way as when storing (e.g. with a wrapping).
- After it is mounted onto a valve in free and wet areas or in areas where temperature is changing it is necessary to connect the space heater – to prevent the actuator against corrosion resulted from water condensed in the control part.
- Remove odd conservation grease as late as before putting into operation.

1.9 Assessment of the product and packaging and removal of contamination

The product and its package are made of recycling materials. Do not throw the single parts of the package and of the product after their life but sort them according to instructions in corresponding executives or regulations of environment protection, and allow their recycling.

The product and its packing are not a source of any environment pollution or contamination and do not contain any dangerous waste.

2. Description, function and specifications

2.1 Description and function

The **UMR XPA** electric actuator is controlled according to version

- by 24 V DC voltage fed to the electric actuator's terminals according to the wiring diagram or by 0/4/12 to 20 mA, 4 to 12 mA resp. 20 to 0/4/12 mA, 12 to 4 mA, (0/2 to 10 V resp. 10 to 0/2 V)
- input control signal and provides for moving the output part of the EA automatically to a position corresponding to the value of the input signal, and other functions as well.
- through Modbus reso. Profibus communication interface.

The electric actuator consists of these main parts (Fig. 1, 1A):

The electric actuator is driven by an **electric motor (1)** supplied (single-phase motor) from the **source board (3)** (single-phase motor) and **control unit (2)** of the DMS 3 electronics.

Position of output element of EA and torque is scanned by **contactless absolute sensor**.

Depending on the version, the DMS3 electronic circuit board may include **an electronic position transmitter (EPV)** without power supply (passive) with output signal 4 to 20 mA.

Space heater (5) is placed at the control board.

In case of power cut or damage of switches the actuator can be controlled by **manual handle** according to instructions stated in chapter 5.1 Service.

Basic modules of DMS3 electronic control system for UMR XPA:

Control unit (2) – main part of system DMS3 – it contains microprocessor, 6 signal LED and 4 buttons for simple adjustment and control of EA, connectors for connection of scanner and sourcing board and communication connector (connection to PC for adjustment and diagnostic), according to version 2 free programmable relays R1 and R2, 1 relay READY and terminals for electric connection.

Sourcing board (3) – secures power supply of electronic and provides an output voltage of 24 V DC, 40 mA for the user, according to version, it contains user terminal board, switching circuits, connector for connection with control unit.

Position scanning unit (4) – secures contactless magnetic position scanning of output element.

Torque reading unit (6) – provides contactless magnetic torque reading.

LED display (7) – shows instant position of EA output member and reports and displays potential errors, which would occur when EA is operated. Signalling motion and failure of the EA is also indicated by LEDs diode. LED display is used only pro type of construction EA without local control.

Manual control: made up by a handwheel with a worm gearing.

Terminal box (Fig. 1B) is as standard equipment for EA with communication protocol Modbus / Profibus.

Other accessories – as optional accessories:

- **3 additional relays module RE3, RE4, RE5** according to version **(8)**.
- **Local electric control module** equipped with 2-line LCD display **(Fig. 7)**.
- Electrical connection in separate terminal box **(Fig. 1B)**.

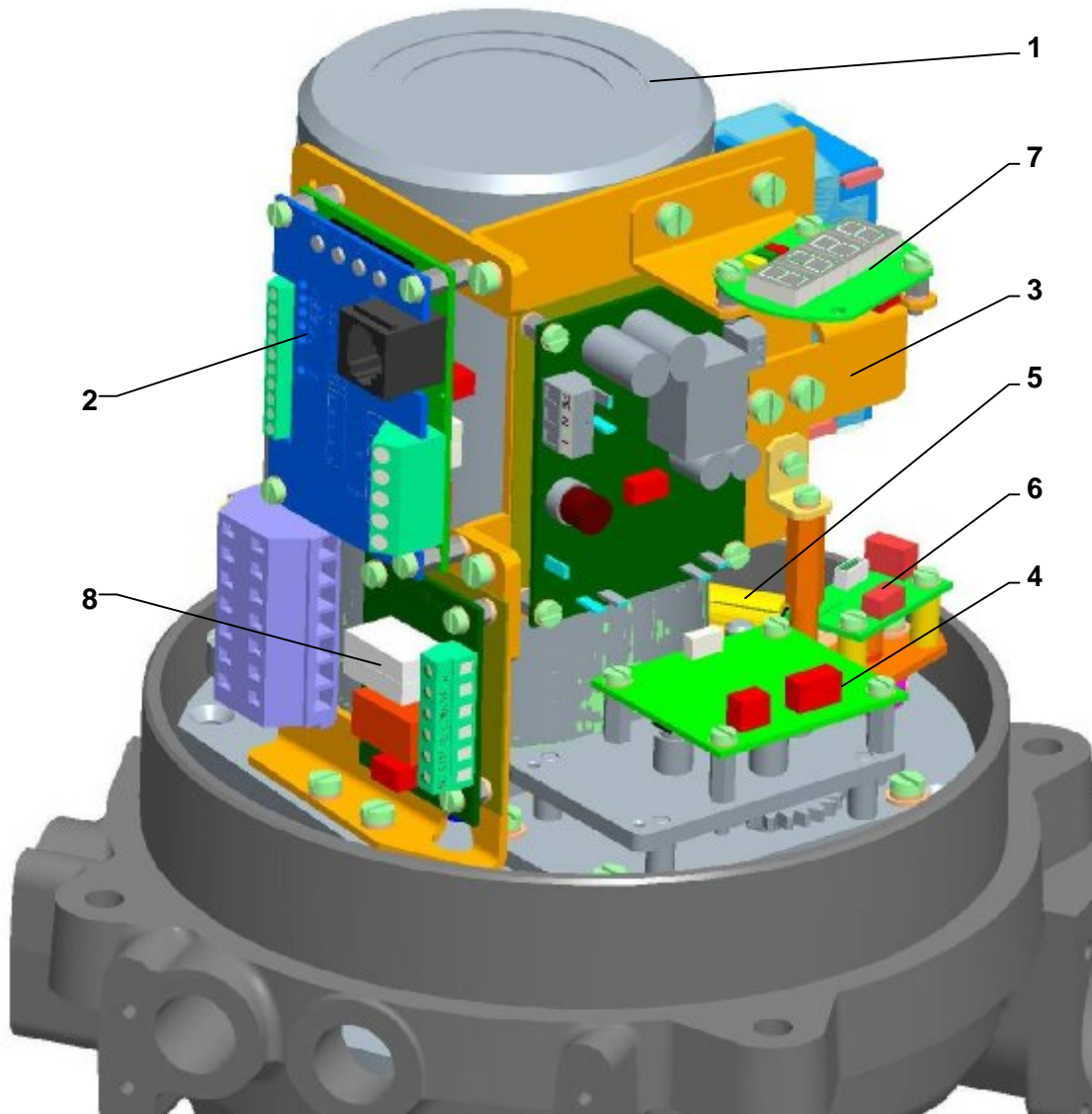

Fig. 1

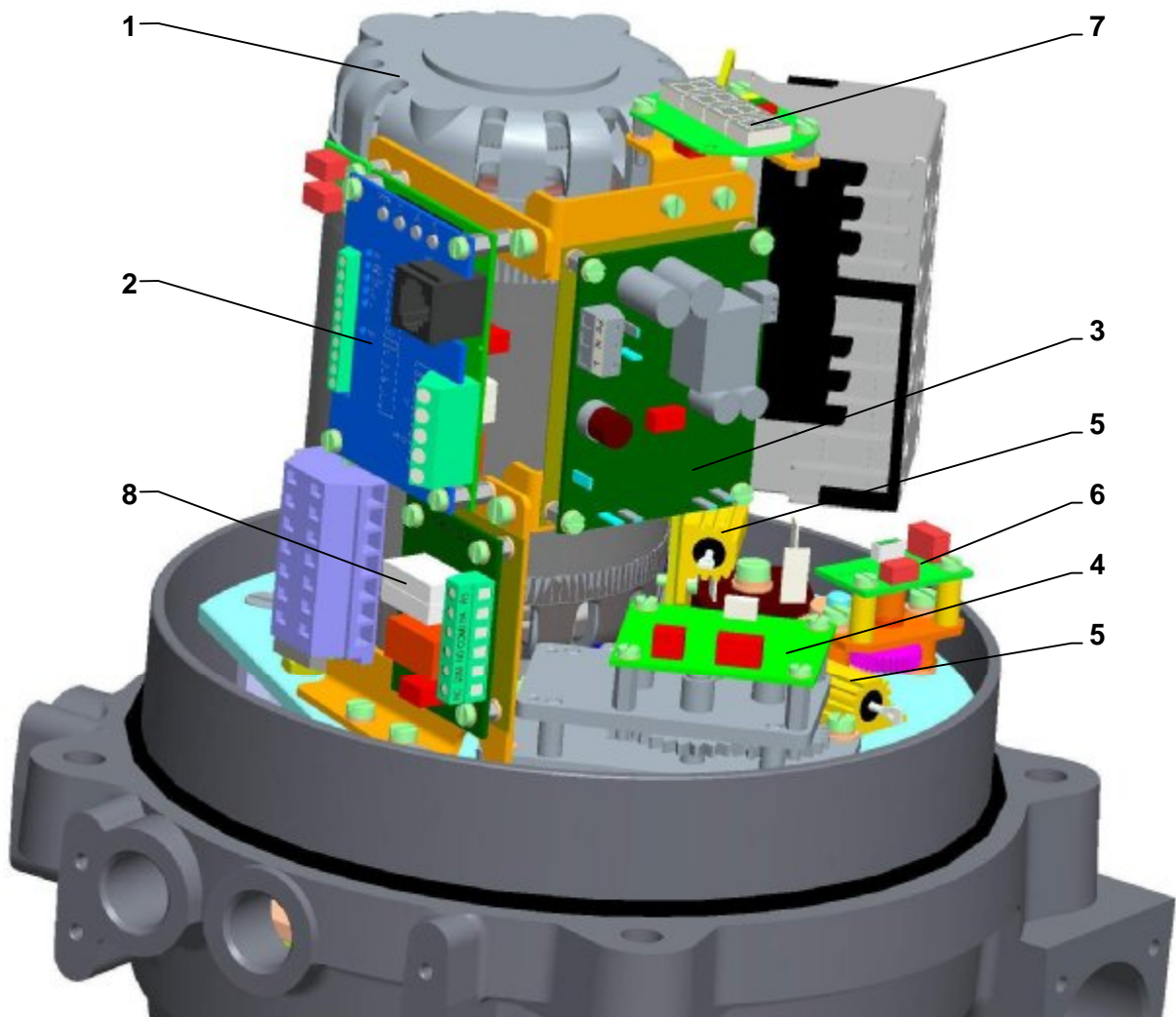

Fig. 1A



Fig. 1B

2.2 Basic specifications

Basic EA specifications:
are given in Table 1.

Table 1: Basic EA specifications

Type number	Operating speed ²⁾	Number revol.	Max. load torque (ON – OFF duty)	Switching-off torque ±10 [%]	Switching-off torque ±10 [%]	Weight	Electric motor ¹⁾						
							Power supply voltage	Nominal			Capacitor capacity.		
								power	speed	current			
	[1/min]	[ot]	[Nm]	[Nm]	[Nm]	[kg]	[V]	[W]	[1/min]	[A]	[μF/V AC]		
1	2	3	5		6	7	8	9	10	11	12	13	
UMR 1PA type number 146	10	1 – 160	20	13	32	14 - 15	Single-phase	230 (220)	40	1350	0,53	1	5/400
	20		10	7	16								
	40		5	3	8								
	10 12		20	13	32								
	20 24		10	7	16								
	40 48		5	3	8								
	10		38	26	64								
	20		20	13	32								
	40		10	7	16								
	20		20	13	32								
	40		10	7	16								
	10		38	26	64								
	20		20	13	32								
	40		10	7	16								

Type number	Operating speed 2)	Number revol.	Max. load torque (ON – OFF duty)	Switching-off torque ±10 [%]	Switching-off torque ±10 [%]	Weight	Electric motor 1)												
							Power supply voltage	Nominal				Capacitor capacity.							
								power	speed	current									
	[1/min]	[ot]	[Nm]	[Nm]	[Nm]	[kg]	[V]	[W]	[1/min]	[A]	[μF/V AC]								
1	2	3	5		6	7	8	9	10	11	12	13							
UMR 2PA	type number 147					20 - 24	Single-phase	230 (220)	120	2600	1,0	1,9	8/450						
														120 60Hz	120	3100	2,0	3,8	8/450
								Three-phase	3x400 (3x380) (3x415)	180	2650	0,6	2,4						
														10	60	40	100		
																		15	48
	20	36	24	60															
					40	18	12	30											

- 1) Switching elements for different type of load (also for EA) defines standard EN/IEC 60 947-4-1.
- 2) Anomaly of operating speed ±10% at 230 V resp. 220 V AC, 3x400 resp. 3x380V resp. 3x415 V AC.
- 3) The total current of EA is the sum of the electronics current (0.15 A) and the electric motor current according to the EA version

Additional technical data:

EA protection enclosure: **IP 66/68** (EN/IEC 60529 within valid edition)

According to definition for EA, enclosure IP68 fulfills following requirements:

- water column max. 10m
- time of continuous submersion in water max. 96 hours

Mechanical ruggedness:

sinusoidal vibrations:..... see Chapter 1.10.2

drop resistance:.....300 drops with acceleration $2 \text{ m}\cdot\text{s}^{-2}$

seismic resistance:.....amplitude of the shock off 6 on Richter scale

Self-locking: the EA is self-locked

Motor's thermal protection: thermo-contact

Electric control:

remote control - movement of output part of the electric actuator is controlled :

- by binary inputs 24 V DC, or
- by unified input signal 0/4/12 up to 20mA, 4 up to 12mA resp. 20 up to 0/4/12 mA, 12 up to 4mA or 0/2 up to 10V, resp. 10 up to 0/2 V according to version.
- potentially controlled through a interface with Modbus/Profibus communication protocol

Power supply of electronics:

- Power supply ZS is used for single phase and three phase versions and feeds the electronic modules built in EA.
- It provides the 24V DC, 40 mA output voltage according to version.

Power sources contain a protective fuse with parameters according to chapter 2.2.2. Electric connection.

Position scanning:

- contactless absolute magnetic.

End positions adjustment:

It is possible to set up (with buttons situated on the control unit, resp. with buttons situated on the local control, resp. program after connecting the EA with PC) the shutting off in end positions as follows:

- Z = Torque + O = Torque
- Z = Torque + O = Position
- Z = Position + O = Torque
- Z = Position + O = Position

Notes:

C = Torque - shutting off at end limit - torque „Closed“

O = Torque - shutting off at end limit - torque „Opened“

C = Position - shutting off at end limit - position „Closed“

O = Position - shutting off at end limit - position „Opened“

Factory's setup of shutting off in end positions is described in the chapter "Adjusting of actuator".

Torque scanning: - contactless absolute magnetic.

Switching-off adjusting:

Disengaging torque is factory adjusting to a maximum value with the $\pm 10\%$ tolerance shown on the nameplate of the appropriate EA.

The user is allowed to modify the switching-off thrust value within the range 50 - 100%, stepped by 10%.

Torque blocking:

The switching-off from torque can be blocked within a certain range of the stroke starting from a stroke end position (max.5%), for time agreed on, in range of 0 to 20 sec..

Output relay (according to version):

- 3x relays ((standard for DMS3 without version Modbus/Profibus) (**READY, R1, R2**) max.

250 V AC/1 A/cos phi=1; max. 30 V DC/2A

- 3x additional relays (options) (**RE3, RE4, RE5**) max. 250 V AC/1 A/cos phi=1; max. 30 V DC/2A

- relays **READY, R1, R2, RE3, RE4 and RE5** are free programmable (their function can be changed with buttons on the control unit, with buttons on the electric local control, or through a PC with the program).

READY relay: - programme selections option – error indication, error or warning, error or not remote, error or warning or not remote. READY relay factory set is shown in the “Adjusting of actuator” Chapter.

R1 and R2, RE3, RE4 and RE5 relay: - programme selections option – disabled, Position O (position open), Position C (position close), Torque O (torque open), Torque C (torque close), Torque O or Torque C, Torque O or Position O, Torque C or Position C, opens, closes, movement, movement – flasher, to position, from position, warning, control – remote, control – local, (not valid for EA without local control), control OFF, **READY relay**.

RE3, RE4, RE5 relays are independent. Factory setting up of the individual relays is shown in the “Adjusting of actuator” Chapter.

Transmitter (output signal) (not valid for Modbus/Profibus version)

Electronic position transmitter (EPV) passive (for single phase versions)- 2-wire connection (without inbuilt power supply)

Current signal.....	4 ÷ 20, resp. 20 ÷ 4 mA (DC)
Voltage at connection of EPV passive	18 up to 30 V DC
Load resistance	max. $R_L = 500 \Omega$
Tolerance of value of output signal of electronic transmitter in end positions:	$\pm 0,5 \%^{1)}$
Tolerance of linearity of transmitter	$\pm 1 [\%]^{1)}$
Hysteresis of transmitter	max. $1 [\%]^{1)}$

1) from nominal value of transmitter referred to output values

Galvanic separation..... output signal is galvanically separated from input control signal

Program possibilities of output signal : 4 ÷ 20 mA, 20 ÷ 4 mA. Factory's setup of output signal is described in the chapter “Adjusting of actuator”.

Electronic controller (N) (not valid for Modbus/Profibus version)– actuation by input control signal

:	0 - 20 mA (0 – 10 V according to version)
.....	4 - 20 mA(2 – 10 V according to version)
.....	12 - 20 mA
.....	4 - 12 mA
.....	20 - 0 mA(10 – 0 V according to version)
.....	20 - 4 mA(10 – 2 V according to version)
.....	20 - 12 mA
.....	12 - 4 mA

Input resistor for signal 0/4/12 up to 20 mA. 4 up to 12 mA $R_{in} = 120 \Omega$

Input resistor for signal 0/2 up to 10 V $R_{in} = 30 k\Omega$

Tolerance of controller's linearity: 0,5 %

Dead of controller: program adjustable within 1 - 10%

Factory's setup of input signal is described in the chapter “Adjusting of actuator”.

Version with Modbus interface:

- o Modbus, line specification: RS485, two-wire design, half duplex.
- o Modbus, Transmission Mode: RTU (8-bit binary data).
- Variants:
 - o Single Channel version with cable or component redundancy or with repeater (common address and communication parameters).
 - o Duo Channel version with cable or component redundancy or with repeater (common address and communication parameters).
- Address: 1 through 247
- Parity:
 - o Even (1 stop bit)
 - o Odd (1 stop bit)
 - o No (2 stop bits)
- Supported transmission rates:
 - o 300 bit/s
 - o 600 bit/s
 - o 1200 bit/s
 - o 2400 bit/s
 - o 4800 bit/s
 - o 9600 bit/s

- 19200 bit/s
- 38400 bit/s
- 57600 bit/s
- 115200 bit/s
- Signal delay (repeater):
 - max. 2.67 μ s
- Bit edge reduction/extension (repeater):
 - max. 1.67 μ s

Version with Profibus interface:

- Profibus, line specification: two-wire design, galvanic separated.
- Variants:
 - Single Channel version.
 - Duo Channel version (simple/redundancy).
- Address 1: 1126
- Address 2: 1126
- Redundancy:
 - Off (for single channel version)
 - Simple (for duo channel version)
- Supported transmission rates:
 - 9,6 kbit/s
 - 19,2 kbit/s
 - 93,75 kbit/s
 - 187,5 kbit/s
 - 500 kbit/s
 - 1500 kbit/s

Control by binary inputs 24 V DC:

- by feeding of 24 V DC to terminals **CLOSE** and **OPEN**.

Programming possibilities of binary inputs I1 and I2 (change is possible only through the programme of PC or using buttons local control)

- for the input **I1** : DISABLED; ESD; DBL (local releasing - not valid for EA without local control), STOP
 - for the input **I2** : DISABLED, ESD; DBL (local releasing - not valid for EA without local control), 2P resp. E2P (the EA can undergo control for the opening direction or closing with the controller ON and I2 input activated with 24 V DC voltage supplied to the terminals to OPEN or CLOSE).
- Factory's setup is described in the chapter "Adjusting of actuator".

Programmable FAILURE REACTION : OPEN, CLOSE, STOP, SAFE POSITION.

Factory's setup is described in the chapter "Adjusting of actuator".

Adjustable elements of electronics:

The EA is possible to adjust with or resetting to different parameters operating the control unit buttons, or with buttons on the local control (according to version), or once it is connected to the PC using the programme and the communication cable connected to the EA control unit communication connector and the EA cover removed.

Space heater (E1)

Space heater - supply voltage:corresponding with motor supply voltage (max. 250 V AC)
 Space heater power output: UMR 1PA cca 10 W/55°C
 UMR 2PA cca 40 W/55°C

Electronic board provides switching of heating element. It is possible to change switching temperatures of the switch from -40°C to $+70^{\circ}\text{C}$ with help of PC and particular software. Factory's setup for shut down of heating element (thermostat) is $+25^{\circ}\text{C}$.

Manual control:

- with manual handle on the upper cover of the EA. Turn the manual handle clockwise to move the output shaft of the EA in the direction "Z – closed".

Output part backlash: max. 5° (at 5 % of maximum switching torque load)

Grease: see chapter Maintenance - extent and periodicity.

2.2.1 Mechanical Connection

- with flanges (ISO 5210, DIN 3338, DIN 3338, Non-standard) resp. GOST R 55510-2013.

Main and connecting dimensions are given in the **dimensional drawings**.

2.2.2 Electric connection

To the terminal board (X, X1, X2, X3) for DMS 3 electronic control:

- 2 terminals (N, L) on the sourcing board for version 24 V AC/DC, with intersection of connection wire 0,05 - 1,5 mm² for solid wire and for flexible wire.
- 3 terminals (PE, N, L) on the sourcing board with intersection of connection wire 0,05 - 1,5 mm² for solid wire and for flexible wire. Max. terminal screw tightening torque 0,5 N.m.
- 3 terminals (2(L1), 3(L2), 4(L3) – for ES UMR1PA version with 3- phase electric motor)) with intersection of connection wire max. 0,08-2,5 mm² - screw-less terminal
- 5 terminals (PE, N, 2(L1), 3(L2) – for ES UMR2PA version with 3- phase electric motor)) with intersction of connection wire max. 0,08-2,5 mm² - screw-less terminal
- 2 terminals (5,6 - for version with wired 3- phase electric motor) with intersection of connection wire max. 0,08-2,5 mm² - screw-less terminal
- 2 terminals (OP, CL - for version with wired 3- phase electric motor) with intersection of connection wire max. 0,08-2,5 mm² - screw-less terminal
- 2 terminals (0 V, + 24V) - with intersection of connection wire max. 0,05 - 1,5 mm² for solid wire. Max. terminal screw tightening torque 0,19 N.m.
- 5 terminals (READY, R1, R2) with intersection of connection wire 0,05 – 1,5 mm² for solid wire and for flexible wire. Max. terminal screw tightening torque 0,5 N.m.
- 10 terminals (COM, CLOSE, OPEN, I1, I2, +IN,-IN,SH,+L,-L) with intersection of connection wire 0,05 – 1 mm² for solid wire and for flexible wire. Max. terminal screw tightening torque 0,19 N.m.
- 6 terminals (COM1, RE3, RE4, COM5, NO5, NC5) - for module additional relays with intersection of connection wire 0,05 – 1,5 mm² for solid wire and for flexible wire. Max. terminal screw tightening torque 0,5 N.m.

To the terminal board (X3) for DMS3 with MODBUS/Profibus protocol:

Terminal boards with spring connection are used, with cross-section of connection wire 0,08 to 2,5 mm²

- 3 terminals (PE, N, U) – supply voltage for version with single – phase electric motor
- 5 terminals (PE, N, U, V, W) – voltage for version with three – phase electric motor
- 2 terminals (21, 22) – voltage for the 24 V DC control
- 10 terminals (13,14,15,16,17) – terminals for the 24 V DC control (COM,CLOSE,OPEN, I1, I2)
- 6 terminals (1,2,3,4,5,6) – terminals single Channel interface of version Modbus//Profibus
- 6 terminals (7,8,9,10,11,12) - terminals redundant of version Modbus/Profibus (by version)
- 3 terminals (18,19,20) – module relay READY (by version)
- 5 terminals (18,19,20,23,24) – module additional relays (by version).

Cable glands for EA with the DMS 3 electronic control

Cable glands for the model without electric local control:

- 3-cable cable glands – 3xM20 - diameter of cable 8 to 14,5 mm

Cable glands for the model with electric local control:

- 2-cable cable glands – 2xM20 - diameter of cable 8 to 14,5mm

Wire stripping length of the wires for screwless terminals is from 8 to 9mm.

Attention: Thermic resistance incoming wires must be minimum +90°C.

Wire cross-section conversion table (mm ² – AWG)	
Wire cross-section	
mm ²	AWG
0,05	30
0,2	24
0,34	22
0,5	20
0,75	18
1,5	16
2,5	14
Tightening torque conversion table (N.m – lbs.-in)	
Tightening torque	
N.m	lbs.-in
0,2	2,7
0,3	4
0,5	7

Protective terminal:

Upon start-up in operation - at equipment installation:

- for safe use of the actuator it is necessary to connect the **outside** and **inside grounding terminal**. The position of the outside and inside grounding terminal can be seen in Fig. 1C and Fig. 1D and fig.1F. For EA version with separate terminal box (version with communication protocol Modbus / Profibus) , is the location of the external and internal protection terminal shown on Fig. 1E.

HP3 insulated eyelet crimping pliers should be used to crimp wire to the outside grounding terminal (fy CEMBRE).

- a power switch/circuit-breaker must be installed on the power supply cable, as close as possible to the device, easily accessible to the operator and identified as the actuator **disconnecting device**. Outside and inside, mutually interconnected and identified with a **protective grounding symbol**.

Product protection

We recommend to use fuses for protection of product.

Fuses:

Actuator power supply board is installed with power supply fuse (F3). Location of the fuse on the power supply board can be seen in Fig.1d.

EA's equipped with a contactless switching module (SSR) are protected with fuses (F4-1 and F4-2) on a holder (Fig. 1G).

Electric connection: - according to the wiring diagram stuck into the case of the EA.

Type	Order code	Voltage	Frequency (Hz)	Electric motor Power / Power input (W)	Max. current EA (A)	Fuse F3 value	Fuse value only for version with SSR) F4-1 F4-2 (6,3x32mm)
UMR 1PA 146	146.X- 0XXXX/YY	230 VAC	50	40/90	0,8	F 2,5 A / 250 V	-
	146.X- LXXXX/YY	220 VAC					
	146.X- TXXXX/YY	120 VAC	60				
	146.X- BXXXX/YY	110 VAC	60				
	146.X- 2XXXX/YY	3x400 VAC	50	40/110	0,42	F 2,5 A / 250 V	-
	146.X- NXXXX/YY	3x380 VAC					
UMR 2PA 147	147.X- 0XXXX/YY	230 VAC	50	60/120	0,86	F 2,5 A / 250 V	-
	147.X- LXXXX/YY	220 VAC					
	147.X- TXXXX/YY	120 VAC	60	70/125	1,5		
	147.X- BXXXX/YY	110 VAC	60	70/125	1,5		
		3x400 VAC	50	90/150	0,56	F 2,5 A / 250 V	-
	147.X- 2XXXX/YY	3x415 VAC					-
	147.X- EXXXX/YY						FF 3,15A/500V
		3x380 VAC	50	120/228	1,3	F 3,15 A / 250 V	-
	147.X- NXXXX/YY						-
	147.X- FXXXX/YY						FF 3,15A/500V
	147.X- 0XXXX/YY	230 VAC	60	150/228	2,5		
		220 VAC	60	150/228	2,5		
		120 VAC	50	180/300	0,82	F 2,5 A / 250 V	-
	147.X- 2XXXX/YY	3x400 VAC					-
	147.X- EXXXX/YY	3x415 VAC					FF 3,15A/500V
		3x380 VAC	50				-
	147.X- NXXXX/YY						-
	147.X- FXXXX/YY					FF 3,15A/500V	



Fig.1C

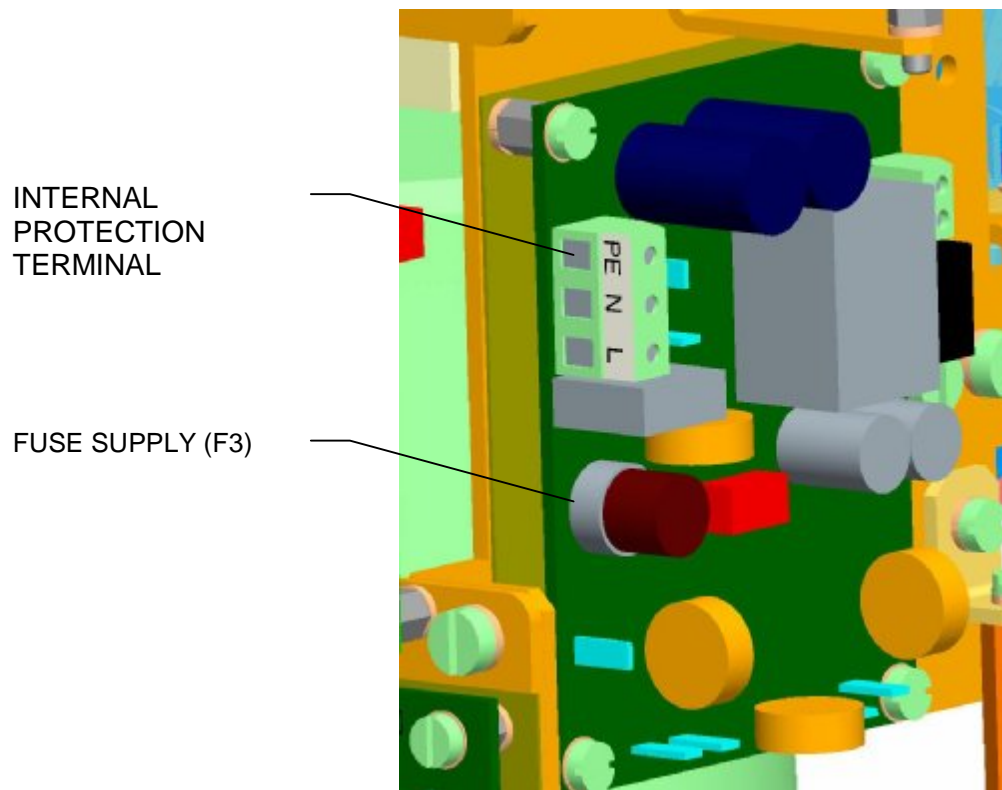

Fig.1D

INTERNAL PROTECTION TERMINAL FOR EA UMR XPA THREE PHASE VERSION

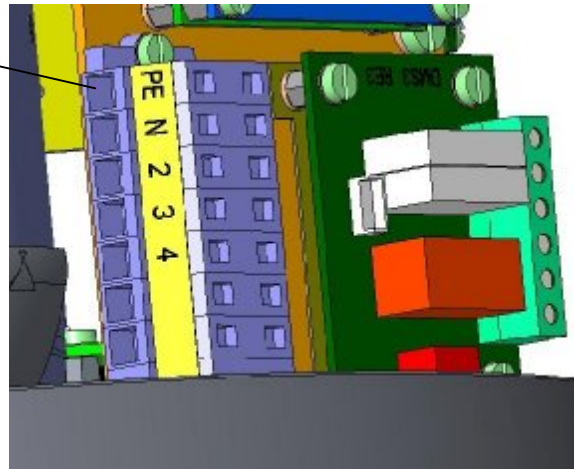
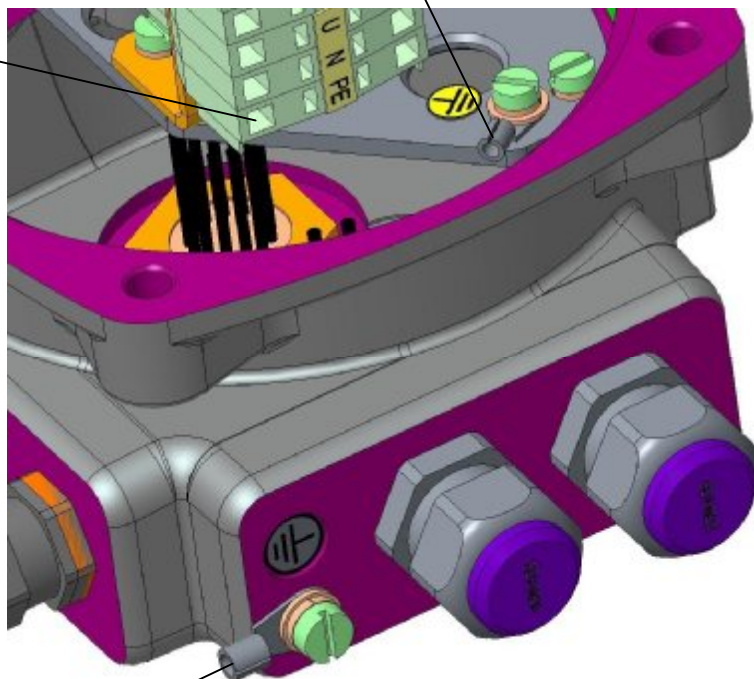

Fig.1F

INTERNAL PROTECTION TERMINAL - ALTERNATIVE IN CASE OF TERMINALS FULL OCCUPANCY

INTERNAL PROTECTION TERMINAL



EXTERNAL PROTECTION TERMINAL

Fig.1E

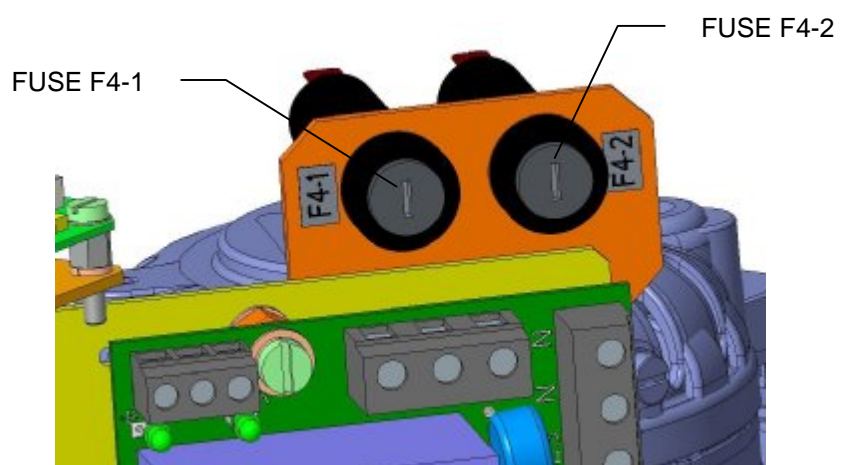

Fig.1G

3. Installation and dismantling of actuator



Abide by safety measures!

Note:

Check again if placement of EA reply to chapter "Operation conditions". In case that operation conditions are different from recommended, consultation with producer is needed.

Before starting of mounting the EA onto the valve:

- Check again whether the EA was not damaged during storing.
- Check whether the adjusted operation stroke and connecting dimensions of the actuator (see the nameplate) are in compliance with the valve parameters.
- In case of inconsonance, perform adjusting according to the part "Adjustment".

3.1 Installation

EA is by the producer adjusted to parameters according to the nameplate.
Before installation put the handwheel on.

3.1.1 Mechanical flange connection

- Defat the abutting areas of the connecting flange of the EA valve or the gear carefully;
- Lubricate the output shaft of the valve/gear with a grease not containing any acids;
- Set the EA to the limit position "closed", set the valve to the same position;
- Put the EA onto the valve with the output shaft reliably stalled in the valve coupling/gear;
- **Attention! Do not adjust EA on an armature forcibly because of damage of the gear!**
- Use the handwheel to turn the EA to fit the openings in the EA and valve flanges if needed;
- Check whether the connecting flange abuts with the valve/gear;
- Fix the flange with four screws (with mechanical strength min 8G) fixed the way the actuator can be moved. Tighten the screws equally in cross;
- At the end check the correctness of the fixture with the valve with rotating the handwheel.

3.1.2 Electric connection and checking of function

Follow up with connecting the EA with mains or master system.



1. Follow instructions in the part "Requirements for specialized...!"

2. While laying electrical line abide by the instructions for heavy current installations. Power supply cables must be of the type approved. Minimum thermal resistance of power supply cables and wires must be +90°C.

3. Cables to terminal boards or connectors lead through cable glands.

4. Before initiation ES into operation internal and external protection terminals are needed to be connected.

5. While fixing the cable it is needed to count with allowed bend radius to avoid damaging or deformation of the sealing element of the cable gland. The leads are to be fixed with the solid construction at most 150 mm from the cable glands.

6. Wires of input control signals to controller and output signals it is necessary to lead them separately with thrust wires or it is necessary to use shielded wires.

7. Reversation of the EA is sure, if the period between switching-off and switching-on of power supply for the reversed movement of the output part is minimally 50 ms.

8. The EA are delivered with cable glands, which in case of tight putting on the leads assure protection enclosure up to IP 68.

9. The face areas of the control part cover have to be before re-mounting clean, coated with grease without any acid (e.g. vaseline) and sealing not damaged to avoid joint corrosion.

Connecting with the master system:

EA can be controlled by according to version:

- analogue signals through the built-in position controller
- binary inputs 24 V DC
- with communication protocol Modbus/Profibus

EA is connected according to wiring diagram under the cover of EA.



In version UMR XPA it is necessary to do calibration in operation according by enclosure assure the optimal function.



Abide by instructions of valve producers, whether switching-off end positions is to be realised with position or torque!.

NOTES:

1. To connect the input control signals and output signals is needed to use shielded wires with steel wire braid (Galvanised Steel Wire Braid GSWB Ξ), for example cable type "Bruflex[®] HSLCH", 4x0, 5 (company Bruns Kabel).
2. Electrical installation of the actuator and its connection to switching, protection and safety devices can be performed by a person with competent qualification only. All the respective standards and electric wiring diagrams cited in the Manual must be kept.
3. The control of all the terminals must be realized after electrical connection of inlet cables. Junction terminals must not be stressed by the connected cables neither by traction nor by bending. Performance of the following measure is recommended in case aluminium wires are used: Immediately before the installation of the aluminium wire the oxidized layer on the wire must be removed and to prevent a new oxidation of the junction a neutral vaseline shall be applied.

Important note:

1) Please avoid (in a standard way) any electric connection of the actuator to the electric net during adjusting, repair and maintenance activities. Keeping this you avoid the potential injury caused by electric current or rotation of the actuator.

3.2 Dismantling**Attention!**

Before disassembly is necessary to disconnect electric supply of electric actuator!

Secure by prescribed way protection against connection of EA to the network and thus potential electrical accident!

- Disconnect the EA from mains.
- Disconnect the leads from the EA terminal boards and loosen the cables from cable glands. Pull out the connectors in case of the connector version.
- Loosen the fixing screws of the EA flange and coupling screws and disconnect the EA from the valve.
- While sending the EA to be repaired put it into a package solid enough to avoid damages of the EA during transportation.

4. Adjusting of actuator



Attention! See the Chapter 1.6 Instructions for staff training
Keep safety regulations! Follow the prescribed procedure to assure that the EA is not connected to mains when live not to cause any injury by electrical current!

EA are delivered adjusted onto parameters according to nameplate from Production plant.

Adjustment is made onto mechanical and electrical connected actuator. This chapter describes how to set up the EA to parameter values within a range applicable for the software. Location of adjustable parts of control board is on **Fig. 6 and Fig. 6a**.

Adjusting is possible:

- by operating the control unit buttons (see **Fig. 6 and Fig. 6a**);
- by operating the local control panel buttons (see **Fig. 7**) – only for the EA s equipped with local control;
- through the programme once the EA is connected to the PC using the communication cable.

For the specific adjustment procedure or individual parameters reset see individual appendixes **74 1053 02, 74 1076 02**.

For facilitating the simple setting of required operation parameters, the control unit is equipped with :

- four setting buttons: **MENU, P, O, C**
- six signal lamps according (LED diode) to **Fig. 6 and Fig. 6a**..

Status indication by means of LED diodes:

LED ERROR (red) – blinks red in case of failure eventually lights in the parameter setting mode

LED OPEN / MENU (green) – in the ON/OFF mode it lights with a control action for the **opening** direction eventually blinks with accessing the MENU mode

LED CLOSE / PAR (red) – in the ON/OFF mode it lights with a control action for the closing direction eventually blinks besides the chosen parameter in the menu and lights up at writing the parameter into the memory

- **LED I1 / SEL** (yellow) – permanent lights with active input I1, or flash in the mode of parameters set up.
- **LED I2** (yellow) – permanent lights with active input I2
- **LED POWER** (green) – it light on at leading the power supply.

Additional LED for version with MODBUS communication

- LED DEX1 (yellow) – permanent lights during Modbus single Channel communication
- LED DEX2 (yellow) – permanent lights during Modbus duo Channel communication.

LED for Profibus version

LED DEX1/ERR (yellow/red) - Profibus chanel 1

yellow - permanent lighting by active communication, chanel in DATA Exchange mode

red - permanent lighting by faulty communication, chanel is not in DATA Exchange mode

red - blinking by Fatal Error (necessary to restart an actuator - switch-off and afterthen switch on)

LED DEX2/ERR (yellow/red) - Profibus chanel 2

yellow - permanent lighting by active communication, chanel in DATA Exchange mode

red - permanent lighting by faulty communication, chanel is not in DATA Exchange mode

red - blinking by Fatal Error (necessary to restart an actuator - switch-off and afterthen switch on)

Electronics - programme selections option according to version:

- **relé R1; R2:RE1-RE5** : disabled; open position, close position, torque-open, torque – close, torque open or torque close, torque open or position open, torque close or position close, open, close, movement, movement flasher, to position, from position, warning, remote control, local control, control shut off, **relay READY**.
- **relay READY**: errors, errors or warnings, errors or no remote, errors or warnings or no remote.
- **output signal** (from EPV passive): 4 to 20 mA; 20 to 4 mA.
- **control (regulating)**: 2P, 3P, 3P/2P I2
- **input control signal** (N): 0/4/12 up to 20 mA, 4 up to 12 mA, resp. 0/2 up to 10 V.
- **input I1**: DISABLED, ESD, DBL (local releasing - not valid for EA without local control), STOP
- **input I2**: DISABLED; ESD; DBL (local releasing - not valid for this type of the EA), 2P resp. E2P (for control programme option 3P/2P I2, or in case of active communication through Modbus/Profibus protocol, allows control using the binary 24V DC inputs with I2 input activated).
- **FAILURE REACTION**: OPEN, CLOSE, STOP, SAFE POSITION

The identical functions cannot be set on **I1** & **I2** inputs in addition to the OFF state (e.g., if the ESD) function is set on **I1** input, it is not possible to select the ESD function on I2 input at the same time).

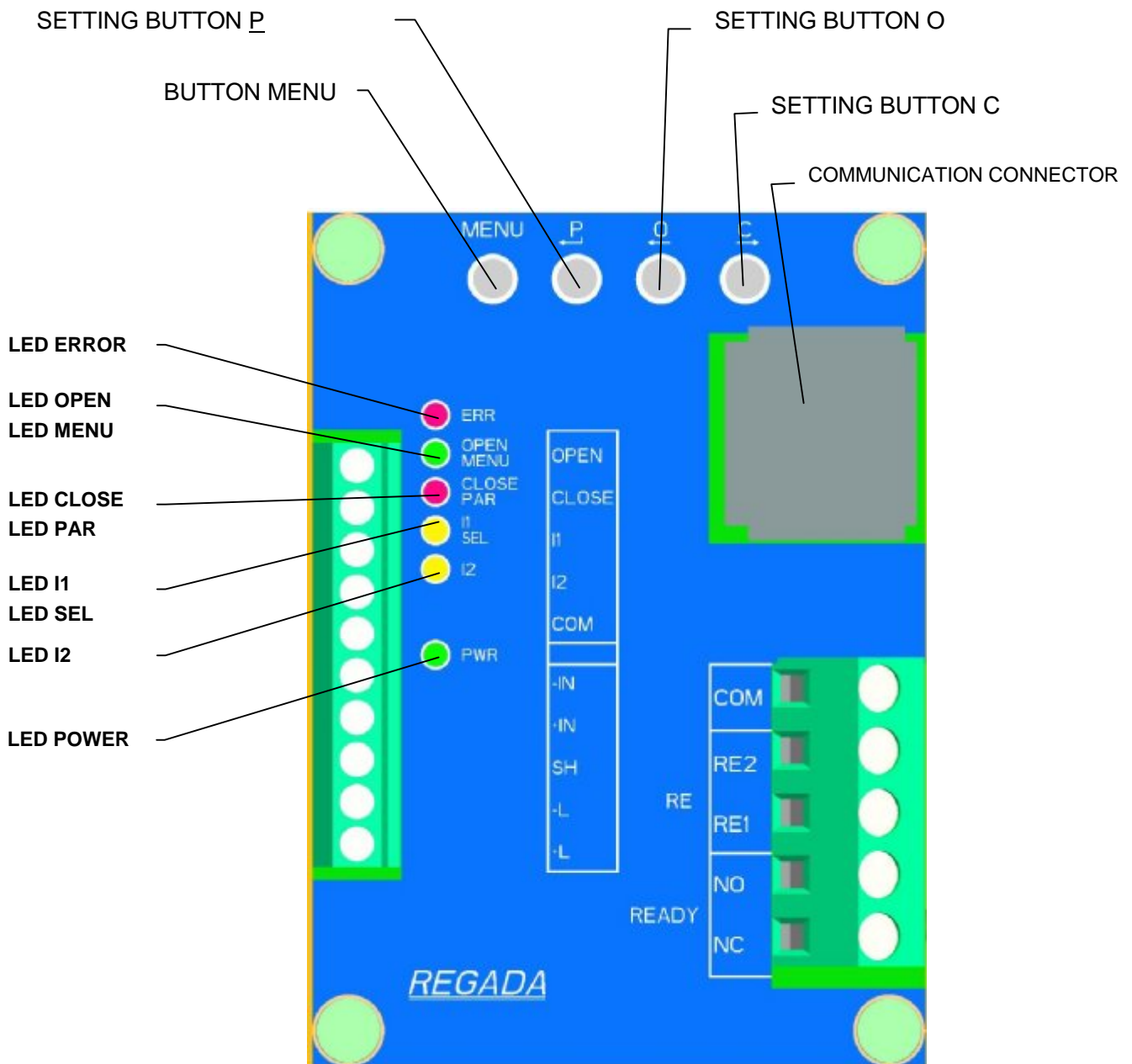

Fig. 6

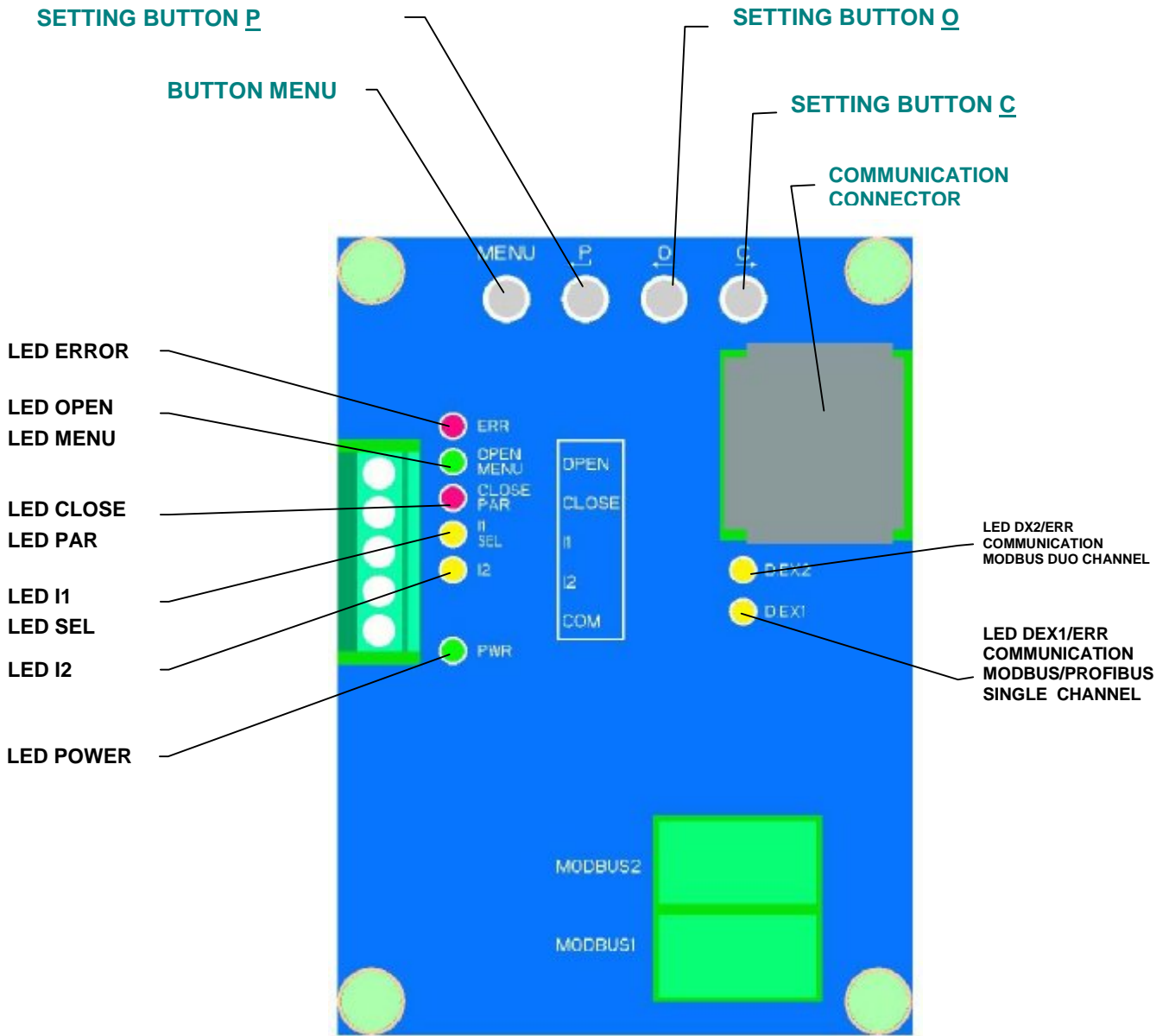

Fig.6a

4.1 EA control set-up options (regulating)

4.1.1 Control setting possibilities for EA´s with DMS3 electronic control

2P CONTROL

Setting-up: **2P** control + other functions, in addition to **STOP** on I1 terminal:

The EA moves either to the OPEN or CLOSE direction with **24V DC** voltage supplied to terminals **OPEN** or **CLOSE**. The EA stops if power supply is cut-off or the end position is reached.

2P PULSE CONTROL

Setting-up: **2P** control + **STOP** function on I1:

The EA moves either to the OPEN direction or closes with **24V DC** voltage pulse supplied on connectors **OPEN** or **CLOSE**. The EA stops – shutting off - once the 24V DC voltage is supplied on I1 connector (STOP) or the set end position is reached.

3P CONTROL (REGULATING)

Setting-up: **3P** control + other functions, in addition to STOP on I1 and other ones in addition to 2P on I2 input.

The EA moves either to the OPEN or CLOSE direction with 0/4/12 up to 20 mA, 4 up to 12 mA (0/2 up to 10V) **input control signal** supplied on terminals **+IN, -IN**. The EA stops once the required position is reached (corresponding with the input control signal supplied) or the set end position is reached.

Note: The ES fails to stop in case that the STOP function is selected on I1 input with 3P control mode and 24V DC voltage supplied on I1 terminal.

3P/2P switched over to I2

Setting-up: **3P/2P** control switched over to **I2** (**2P** function is automatically selected for **I2** input function in selecting this control option) + other functions in addition to STOP on I1:

The EA moves either to the OPEN or CLOSE direction with 0/4/12 up to 20 mA, 4 up to 12 mA (0/2 up to 10V) **input control signal** supplied on terminals **+IN, -IN**. The EA stops once the required position is reached (corresponding with the input control signal supplied) or the set end position is reached.

The EA stops to respond to signal **0/4/12 to 20 mA, 4 to 12 mA (0/2 to 10 V)** input control signal and rests in case of **I2 active input** (with 24V DC constantly ON or OFF – as per I2 function set-up to ACTIVE – or supplied on I2 connector). The EA is allowed to move either to the **OPEN** or **CLOSE** direction with **24V DC** voltage supplied to terminals **OPEN** or **CLOSE**. The EA stops if power supply is cut-off or the end position is reached. The EA stops to respond to the input control signal and fixes its position once the supply voltage on I2 is OFF.

3P/2P switched over to I2 (PULSE 2P)

Setting-up: **3P/2P control switched over to I2** (**2P** function is automatically selected for **I2** input function in selecting this control option) + other functions in addition to **STOP** on I1:

The EA moves either to the OPEN or CLOSE direction with **input control signal** 0/4/12 up to 20 mA, 4 up to 12 mA (0/2 up to 10V) supplied on connectors **+IN, -IN**. The EA stops once the required position is reached (corresponding with the input control signal supplied) or the set end position is reached.

The EA stops to respond to **0/4/12 to 20 mA, 4 to 12 mA (0/2 to 10 V)** input control signal and rests in case of **I2 active input** (with 24V DC constantly ON or OFF – as per I2 function set-up to ACTIVE – or supplied on I2 terminal). The EA is allowed to move either to the OPEN or CLOSE direction with **24 V DC** voltage pulse supplied connectors **OPEN** or **CLOSE**. The EA stops once the 24V DC voltage is supplied on I1 terminal (STOP) or the set end position is reached.

The EA stops to respond to the input control signal and fixes its position once the supply voltage on I2 is OFF.

4.1.2 Control setting possibilities for EA's with DMS3 electronic control with MODBUS/Profibus protocol

2P CONTROL (two position controller)

Setting: the two position controller is activated by setting the bit 3P=0 in the corresponding Modbus/Profibus register:

The EA moves in the direction of open or closed **when the bits are set as OPEN**, resp. **CLOSE in the corresponding Modbus/Profibus register**.

3P CONTROL (three position controller)

Setting: the three position controller is activated by setting the bit 3P=1 in the corresponding Modbus/Profibus register:

The EA moves in the direction of open or closed **in accordance with the requirements sent through the Modbus/Profibus interface**.

EMERGENCY CONTROL

Note: In cases where the EA is equipped with a local control, it is possible to activate the emergency control only if the local control block is set to remote control. The local control block has higher priority than the **ESD** or **E2P**.

- **ESD (Emergency Shutdown)** – is activated when the function parameter is set as **I1=ESD** and the I1 input is activated or when the function parameter is set as **I2=ESD** and the I2 input is activated. The EA takes up the position which corresponds to the settings of the **response to error parameter after input activation**. The **ESD emergency control has higher priority than the E2P control**.
- **E2P (Emergency 2P)** – is activated when the function parameter is set as **I2=E2P** and the I2 input is activated. The **E2P emergency control has lower priority than the ESD control**. Emergency 2P operates in two modes and uses the following inputs:
 - **Permanent signal** – the EA opens or closes only when a signal is present on the **OPEN, CLOSE inputs**.
 - **Impulse mode** – the EA opens or closes after supplying an impulse to the **OPEN, CLOSE inputs**. The EA is stopped after supplying an impulse to the **I1 input**. This mode is similar to the settings of the function **I1=STOP**.

4.2 Procedure for setting individual parameters and the register of errors and warnings

- is given in the separate attachment 74 1053 02 resp. 74 1076 02 of these operating instructions.
The factory default setting of individual programmes shown in Table 3 and Table 4, as long as otherwise specified by the customer:

Table 3

Factory default settings of individual parameters in version without local control; possibility to set-up by operating the control unite buttons.

For the individual parameters set-up see appendix 74 1053 02

MENU			NAME	FACTORY SETTING-UP	
DMS3	MODBUS	PROFIBUS			
1			TORQUE	100% of value shown on nameplate for OPEN & CLOSE direction.	
2			END LIMIT	- C = Position + O = Position - end position switching closed and open from position if valve type is not specified - C = Torque + O = Position - closed in end by thrust position and end position switching open from position for single-seat valves - C = Torque + O = Torque – switching in both end positions by thrust for double-seat valves	
3			TORQUE BLOCKING	- 2 sec. blocking time - 5% blocking position for OPEN & CLOSE direction	
4			RELAY READY	- errors (READY COM-NO relay contacts closed in error free conditions)	
5			RELAY R1..RE5	- position O for relay R1 - position C for relay R2 - from position 95% for relay RE3 - To position 5% for relay RE4 - disabled for RE5 relay	
6	-	-	CPT (output signal)	4 to 20 mA	
7	-	--	REGULATION – (according to specification)	2P	3P
			ANALOG INPUT	-	4 to 20 mA (2 to 10 V)
-	5	-	ADDRESS	2	
-	-	6	ADDRESS 1	2	
			ADDRESS 2	3	
-			BAUDRATE PARITY REDUNDANCY	115200 bit/s EVEN OFF (for single Channel version) COMPONENT (for duo Channel version)	
-	-	7	REDUNDANCY	OFF (for single Channel version) Single (for duo Channel version.)	
8			DEAD ZONE	-	3 %
9			FAILURE REACTION	STOP	

Other parameters set-up is possible to change only by using the PC software

TITLE	FACTORY SETTING-UP
DIRECTION OF ROTATION	clockwise
THERMOSTAT TEMPERATURE	25 °(space heater OFF temperature)
INTERNAL DEAD ZONE	2 % (only for 3P)
Safe position	0 %
FUNCTION I1	ESD
ACTIVE I1	high level
FUNCTION I2	DISABLED
ACTIVE I2	high level

THERMAL FUSE FAILURE	at this type of EA functionless
THERMAL FUSE RESET	at this type of EA functionless
CYCLE MODE	DISABLED
CYCLE RUNNING TIME	10 s
CYCLE PAUSE	50 s
CYCLE POSITION O1	0 %
CYCLE POSITION O2	100 %
CYCLE POSITION C1	0 %
CYCLE POSITION C2	100 %
O AND C TOLERANCE	1 %
CREATE BACKUP	START
RESTORE FROM BACKUP	START
RESTORE FACTORY SETUP	START
ACTIVE ERRORS	CLEAR
DIRECTION OF ROTATION	clockwise
REDUNDANCY	OFF
CONNECT TIME (Modbus)	3s

Table 4
Factory default settings of individual parameters in version with local control; possibility to set-up by operating the local control buttons. For the individual parameters set-up see appendix 74 1076 02.

MENU			NAME	FACTORY SETTING-UP	
DMS3	MODBUS	Profibus			
	1		JAZ/LANGUAGE	English (select language on LCD display)	
	2		POSITION O	work angle range set as per EA specification	
	3		POSITION C		
	4		REG. CALIBR.	START	
	5		END LIMIT	<p>- C = Position + O = Position - end position switching closed and open from position if valve type is not specified</p> <p>- C = Torque + O = Position - closed in end by thrust position and end position switching open from position for single-seat valves</p> <p>- C = Torque + O = Torque - switching in both end positions by thrust for double-seat valves</p>	
	6		TORQUE O	100% of value shown on nameplate	
	7		TORQUE C	100% of value shown on nameplate	
	8		BLOCK. TIME	2 s	
	9		BLOCK. POS. O	5 %	
	10		BLOCK. POS. C	5 %	
11	-	-	CPT (output signal)	4 to 20 mA	
12	-	-	REGULATION-(according to	2P	3P
13	-	-	ANALOG. INPUT	-	4 to 20 mA (2 to 10 V)
14	16	14	DEAD ZONE	-	3 %
15	17	15	INT. DEAD Z.	-	2 %
16	18	16	FAIL. REACT.	STOP	
17	19	17	SAFE POSIT.	0 %	
18	20	18	FUNCTION I1	ESD	
19	21	19	ACTIVE I1	high level	
20	22	20	FUNCTION I2	DISABLED	
21	23	21	ACTIVE I2	high level	
22	24	22	THERMO. FAIL. (THERMAL FUSE	at this type of EA functionless	
23	25	23	THERMO. RESET (THERMAL FUSE	at this type of EA functionless	
24	26	24	RELAY READY	errors	
25	27		RELAY 1	Position O (POSITION OPEN)	

26	28	26	RELAY 1 POS.	0 %
27	29	27	RELAY 2	Position C (POSITION CLOSE)
28	30	28	RELAY 2 POS.	0 %
29	31	29	RELAY 3	FROM POSITION
30	32	30	RELAY 3 POS.	95 %
		31	RELAY 4	TO POSITION
		32	RELAY 4 POS.	5 %
33	35	33	RELAY 5	DISABLED (OFF)
34	36	34	RELAY 5 POS.	0 %
35	37	35	CYCLE MODE	DISABLED
36	38	36	CYCLE RUN. T.	10 s
37	39	37	CYCLE PAUSE	50 s
38	40	38	OC TOLERANCE	1 %
39	41	39	INFORMATION	TORQUE
40	42	40	RESTORE BACK.	START
41	43	41	CREATE BACK.	START
42	44	42	RESTORE FACT.	START
43	45	43	ACTIVE ERR:	CLEAR
-	-	44	DIRECTION OF ROTATION	clockwise
-	11	-	ADDRESS	2
-	12	-	BAUDRATE	115200bit/s
-	13	-	PARITY	EVEN
-	14	-	REDUNDANCY	OFF (for single Channel version) COMPONENT (for duo Channel version)
-	15	-	CONNECT TIME	3s
-	-	11	ADDRESS 1	2
-	-	12	ADDRESS 2	3
-	-	13	REDUNDANCY	OFF

Other parameters set-up is possible to change only by using the PC software	
NAME	FACTORY SETTING-UP
DIRECTION OF ROTATION OF EA	clockwise
THERMOSTAT TEMPERATURE	25 °(space heater OFF temperature)
CYCLE POSITION O1	0 %
CYCLE POSITION O2	100 %
CYCLE POSITION C1	0 %
CYCLE POSITION C2	100 %
LCD CONTRAST	0

Warning 1: When the input control signal is set to the value 0 , 20 mA (0 to 10 V), or 20 , 0 mA (10 to 0 V) and the input control signal fails, then the EA keeps the position as with a 0 mA (0 V) input signal (EA doesn't recognise between input signal fail and 0 mA (0 V) input signal) - not his does not apply to EA 's equipped with a Modbus/Profibus protocol.

Warning 2: Auto-calibration process doesn't run if triggered in time when the EA is in error state, e.g. EA is overloaded (EA is switched -off from torque). In such case is necessary to resolve issue, e.g. the EA must be moved in a position in which is not switch-off from torque and to start the auto-calibration again.

Warning 3: Calibration process must be performed at any change of the operating angle value of more than 10%.

Warning 4: Operate adjusting button **P** on the control to activate the calibration process or start it from **MENU 4** in the version with local control (use the buttons on local control) or from the programme once the EA is connected to the PC. All calibration start methods have been equal.

Warning 5: In case that EA with supply voltage 3x400V AC after calibration start shows the error „rotation direction“ (error No. 7), it is necessary to stop EA by switching-off the supply voltage and change the phases sequence on the terminals 2 and 3 (change mutually phases wires) and after switching-on the supply voltage run n the calibration again.

Rotation direction definition of the electric actuator's output element:

Electric actuator is set by the producer in the following way: while looking at the output shaft of the actuator from the upper cover side, the output shaft moving in the direction "Close" is rotating clockwise. It means that the direction of rotation of the actuator is set as **clockwise**.

In case the direction of rotation shall be changed the parameter „Direction of rotation of the actuator“ must be adjusted as **anticlockwise**. This parameter can be adjusted through the PC only by use of the EHL Explorer SW. The PC must be connected to the actuator via communication cable and the window "Parameters" used for direction adjustment, *in some cases by local control buttons*.

4.3 Putting an EA into operation when the EA is set up and connected with the armature already in the production plant (starting the calibration)

If EA is delivered from manufacturing plant joined with valve, or with control device, **calibration** must be performed to ensure correct operation, under actual pipeline conditions.

The procedure is as follows:

- fit the given assembly into the specified technology complex
- connect the EA on the supply voltage electrically according to the wiring diagram and chapter Electric connection and checking of function.
- introduce the EA into an mid-position (see Note 2 presented above)
- switch on the supply voltage
- **start the EA calibration** by pressing the **P** button on the control unit **for 2 seconds as minimum** until LED ERROR (red), LED MENU (green) and LED PAR (red) light up – see also the procedure in the separate attachment **No.74 1053 02**
- release the **P** setting button
- after releasing the **P** button the calibration procedure starts – inertia measuring
- after the calibration procedure is finished, the EA is prepared for its operation and starts to response to control inputs
- if changes to some parameters would be necessary, proceed please according to the instructions given in the separate attachment **No. 74 1053 02**.

4.4 Putting an EA into operation when the stroke and parameter setting done by the producer suit to your needs

When an EA is delivered from the producer without armature and the setting of stroke (stroke end positions) and other parameters done by the producer suit Your needs, please proceed as follows:

- connect the EA with the armature to be controlled (**according to chapter 2**) and fit this assembly into the specified technology complex
- connect the EA electrically according to the wiring diagram and chapter Electrical connection and checking of function
- introduce the EA into an mid- position (see Note 2 presented above)
- switch on the supply voltage
- start the EA calibration by pressing the **P** button on the control unit **for 2 seconds as minimum** until LED ERROR (red), LED MENU (green) and LED PAR (red) light up – see also the procedure in the separate attachment No. 74 1053 02
- release the **P** setting button
- after releasing the **P** button the calibration procedure starts
- after the calibration procedure is finished, the EA is prepared for its operation and starts to response to control inputs
- if changes to some parameters would be necessary, proceed please according to the instructions given in the separate attachment No. 74 1053 02.

4.5 Putting an EA into operation when it is necessary to do a change to the stroke (setting new end positions), and the other parameter setting done by the producer suits to your needs

When an EA is delivered from the producer without armature, and the setting of other parameters done by the producer suit to your needs, and it is necessary to do a change to the EA stroke, proceed as follows:

- connect the EA with the armature to be controlled (according to chapter 2) and fit this assembly into the specified technology complex,

- connect the EA electrically according to the wiring diagram and chapter Electrical connection... ,turn on the power supply, without connection of the control signals fed into EA (The EA will report an error i.e. alarm No. 2 or No. 27 (missing input control signal - or Modbus/Profibus activity),
- set the ES (*using manual control**) to end position **closed** and push button **C** for at least **2s**, until LED ERROR (red), LED MENU (green) and LED PAR (red) come on – the **closed** end position is thus recorded in memory – see description in separate annex **No. 74 1053 02**,
- release the **C** setting button,
- set the ES (*using manual control**) to end position **opened** and push button **O** for at least **2s**, until LED ERROR (red), LED MENU (green) and LED PAR (red) come on – the **opened** end position is thus recorded in memory – see description in separate annex **No. 74 1053 02**,
- release the **O** setting button,
- **introduce** the EA into an mid osition (see *Note 2* presented above),
- by pressing the **P** pushbutton on the control unit for at least **2s** activate the EA calibration until LED ERROR (red), LED MENU (green) and LED PAR (red) come on – see also description of the procedure in separate annex **No. 74 1053 02**,
- release the adjustment pushbutton **P** - upon release of the **P** pushbutton, the calibration process is started,
- turn on the control signals, EA is ready for operation and responds to control inputs,
- if any of the parameters need to be changed, proceed according to the instructions in separate annex **No. 74 1053 02**,

* This applies to setting of EA to be controlled by 2P and 3P or 3P/2P switched by I1, at the same time with standard setting of menu 9 FAILURE REACTION: STOP!

If the input control signal is set to one of the ranges starting from 0 mA, it is necessary to change the range to a different one. If this is not the case and a control signal is not supplied, the servodrive output component will take up the position corresponding to 0 mA. After recording the new limit positions change the value of the input control signal and response to error to the required parameters.

Note: in cases where the sequence is implemented using a PC in the EHL Explorer programme or using local control, neither the change of response to error nor disconnection of the control signals is required.

4.6 Setting other parameters

If changes to some parameters would be necessary, proceed please according to the instructions given in the separate attachment **No 74 1053 02**.

4.7 Error messages from the control unit

The EA electronics makes possible to identify some failures of EA. The failure is signalled by flickering LED ERROR (red) on the control unit (**Fig.6 and 6a**). An error has also been indicated on the LED display. An error is indicated on the LCD display in the local control EA version.

The list of errors and warnings compiled by the producer is presented in **table 5** (chapter 5.4).

The list of errors and warnings and the way for identifying a given error as well are presented in the separate attachment **No 74 1053 02**.

A field serviceman is only entitled to change the errors and warnings set using the programme once the EA is connected to the PC.

5. Service and Maintenance

5.1 Service



1. In general it is supposed that the EA is serviced by a qualified person as required in the Chapter 1!
2. After the EA is put into operation it is necessary to check whether during manipulation its surface finishing was not damaged – the damages should be eliminated to prevent the surface against deterioration caused by corrosion!

- The EA **UMR XPA** requires just an insignificant service. The reliable operation is determined by the correct putting into operation.
- The service of the EA results from the operation conditions and generally consists in treating the information for subsequent performing of a required function. The EA can be controlled by remote control electrically or manually on the place of their installation. The manual control is available with a hand wheel.
- The service staff should arrange the required maintenance and prevent the actuator during operation against impacts of environment and climate what exceed the frame of allowed influences stated in the Chapter "Operation Conditions".
- It is necessary to avoid overheating of the EA surface, exceeding of parameters stated on the nameplate and abnormal vibrations of the EA.

Manual control:

- If the manual control is needed (adjustment, function checking, failures etc.) the staff can reset the regulated member using the handwheel. While rotating the handwheel clockwise the output element moves in the direction "CLOSING".

Electric local control: - additional equipment (Fig.7)

If necessary in the case of accession, function check and so on, it is possible to preset EA or change some parameters by local electric control with secured power feeding.

It is possible to control after removing of the padlock (1). Control mode selection is changed by sequential pressing of the button (2) **REMOTE-OFF-LOCAL** to "Remote" "Shut off", "Local", "Shut off", which is displayed on 2 rows LCD (6). Signalling motion and failure of the EA is also indicated by LEDs diode (7).

Mode "Shut off" – it is possible to change some parameters in this mode in particular menus.

Mode "Local" – it is possible to control EA by the local buttons in this mode - (3) **OPEN**, (5) **STOP**, (4) **CLOSE**.

Mode "REMOTE" – it is possible to control EA by the commands from superior remote system

Proceeding in setup of particular parameters in the mode "SHUT OFF" is described in the independent amendment No. 74 1076 02, which is delivered together with EA equipped by local electric control.

When you finish the work in the "REMOTE" mode put the padlock on the button (2) again. This measure would be received because of potential unauthorized person's intervention.

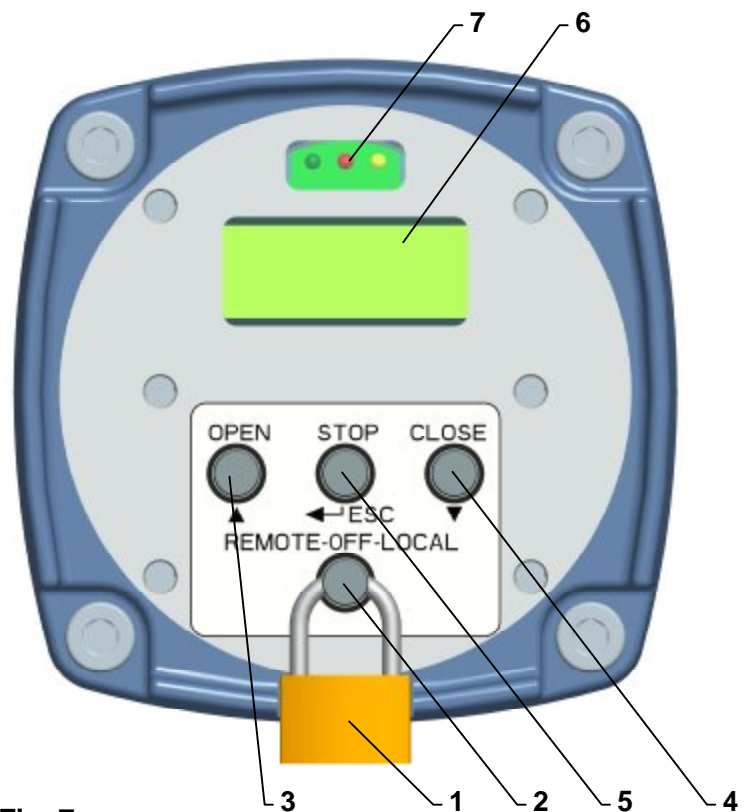

Fig. 7

Note: Modes of Local or Remote control is conditioned by program choices of inputs I1 and I2. In the case that inputs I1 or I2 are programmed for "Local releasing", it is only possible to control the EA by local control with active input I1 or I2.

5.2 Maintenance - extent and periodicity

During inspections and maintenance is needed to tighten all screws and nuts that affect the tightness and coverage. Similarly, once a year should be checked and if necessary tighten mounting screws of the terminal wires and assuring of the slip-on joints with wires.

The interval between two preventive inspections is four years.

The replacement of cover gaskets and gasket of an oil filling is needed in case of damage or after 6 years of the operation.

The grease in the supplied actuators is designed for the lifetime of the product. It is not necessary to change the grease during the operation of the actuator.

During inspection, replace the sealing O-ring (see Chapter 5.3) between the bottom and top cover - replace with original O-ring from manufacturer.

Lubrication:

- the gearbox and drive mechanism on the control board - grease:
 - in versions with temperatures -25°C till +55°C - grease μ HF 401/0, resp. GLEITMO585
 - in versions with temperatures -50°C till +40°C - grease ISOFLEX TOPAS AK 50
 - in versions for climate with temperatures -60°C till +40°C grease DISCOR R-EP 000.



Lubrication of the valve stem is independent on maintenance of the EA!

After every potential flooding of the product check, whether there is no water inside. After eventual water penetration, dry the product before repeated putting into operation and replace damaged sealings, resp. other parts of EA. identically check also tightness of cable bushings and replace them, if they are damaged.

- Every six months it is recommended to perform one check move in frame of adjusted operation stroke to verify reliability of functioning with setting back to the original position.
- If the audit rules do not determine else the inspection of EA is performed ones a year and tightening of all connecting and grounded screws have to be checked to avoid overheating.
- After 6 months from putting of EA into operation and once a year it is recommended to check tightening of fixing screws between the EA and the valve. (Tighten the screws with the cross system.)

- While connecting and disconnecting of the EA check the tightness of cable glands – those with damaged sealings should be replaced by new ones of the approved type!



Keep the EA clean and take care about removing impurities and dust. The cleaning has to be performed regularly according to the operation possibilities and requirements.

5.3 Troubleshooting

At failure of power supply the EA stops in the position where it was before the failure. If needed the EA can be set only with the manual control (the handwheel). After restoration of power the EA is prepared for operation.

In case of failure of any element of the EA it can be changed by a new one. Entrust the change to a service centre.

If your EA would fail, proceed please according to the instructions for the under guarantee and after-guarantee.

Note: If the EA requires dismantling follow the chapter "Dismantling".

The EA electronics makes possible to identify some failures of the electric actuator. The control unit blinking LED ERROR indicates the failure (**Fig. 6,6a**) or the error is displayed on the LED (**see Fig. 1,1A**), or the LCD display (**see Fig. 7**). The list of errors and warnings and the way for identifying a given error as well are presented in the separate attachment No 74 1053 02.

The list of errors and warnings compiled by the producer is presented in **table 5**. A change to the list of errors and warnings in the EA is only possible within a service intervention, through the program installed in a PC.

Table 5-setting error flags and warning flags as at the delivery		
PARAMETER	ERROR	WARNING
ESD		X
Analog Input – not valid for Modbus/Profibus protocol		X
Modbus/Profibus activity – only for Modbus/Profibus protocol		X
Wrong command	X	
Torque		X
Torque check		X
Torque calibration	X	
Regulator calibration		X
Stroke (turns sum)	X	
Wrong position	X	
Spin	X	
Spin direction	X	
RAM	X	
ROM	X	
EEPROM		X
Bus	X	
I2C	X	
Reset		X
Voltage +5V		X
Parameters	X	
Set mode		X
Relay		X
Temperature <		X
Temperature >		X
Phase	X	
Power frequency	X	
Thermal fuse	X	
Manual control	X	
Position module	X	
Position module type	X	
Position sensor 1	X	
Position sensor 2	X	
Position sensor 3	X	
Position sensor 4	X	
Torque module	X	
Torque module type	X	
Torque sensor	X	
LED module	X	
LED module type	X	
LCD module	X	
LCD module type	X	
Power Supply/Relay module	X	
Power Supply/Relay module type	X	
E2P	X	
Profibus Channel 1- only for version with Profibus	X	
Profibus Channel 2- only for version with Profibus	X	

Notes: **X** – the error or warning flag is activated.
 With the **error flag**, the EA takes the positron defined for the FAILURE REACTION function eventually stops (depending on the kind of the error), and it will not operate until the error is removed.
 With the **warning flag**, the EA continues in operation.
 The user is advised on error or warning through the READY relay (according to the relay setting), eventually through the program after connecting the EA with a PC.

Note 1: In some cases having the error removed the electric actuator must be restarted by switching-off the voltage supply to the electric actuator for about 3 sec.

For repairing eventually the electronics use the fuse – see Fig.1D (F3) for example SHURTER MSF 250, or a sub miniature SIBA 164550 xxx (see chapter 2.1.2), which is located on source board.



Taking the EA to pieces for repair purposes is allowed only by professionally qualified persons trained in the production plant or by a contracted service centre!

6. Accessories and Spare Parts

As accessories the **handwheel** is packed with the product.

6.1 List of the Spare Parts

Table 8: Spare Parts

Table 8			
Spare part			
Spare part	Order Nr.	Position	Figure
Electric motor; 40 W; 230V AC (3x400 V AC); 50 Hz; (UMR 1PA)	63 592 076	2	1
Electric motor; 40 W/110 VA; 3x400V AC; 50 Hz; (UMR 1PA)	63 592 054	2	1A
Electric motor; 40 W/110 VA; 3x400V AC; 50 Hz; (UMR 1PA)	63 592 054	2	1
Electric motor; 120 W/228VA; 230V AC; 50 Hz; (UMR 2PA)	63 592 394	2	1A
Electric motor; 180 W/300VA; 3x400V AC; 3x415 V AC; 50 Hz; (UMR 2PA)	63 592 330	2	1A
Capacitor 5 μ F (UMR 1PA)	63 540 001	2	1
Capacitor 8 μ F (UMR 2PA)	Electric motor components	2	1
DMS3 ZS switch – mode power supply for 230 V AC and 115 V AC	64 051 103	3	1, 1A
Position scanning unit DMS3 SM4	64 051 088	4	1, 1A
Torque scanning unit DMS3 ST	64 051 080	6	1, 1A
Control unit of the electronics DMS3 J1 (0/4/12 up to 20 mA, resp.4 up to 12 mA)	64 051 075	2	1, 1A
Control unit of the electronics DMS3 J3 (0/2 up to 10 V)	64 051 061	2	1, 1A
Control unit of the electronics DMS3 J2 (without input and output)	64 051 060	2	1, 1A
Control unit of the electronics MODBUS single Channel	64 051 051	2	1,1A
DMS3 M2 - Control unit MODBUS Duo Channel	64 051 052	2	1,1A
DMS3 P1 - Control unit PROFIBUS Single Channel	64 051 037	2	1,1A
DMS3 P2 - Control unit PROFIBUS Duo Channel	64 051 038	2	1,1A
DMS3 L2 LED display	64 051 081	7	1, 1A
DMS3 LCD display	64 051 082	6	7
DMS3 H3.4 local control sensor	64 051 084		
DMS3 RE3 Module of additional relays	64 051 065	8	1, 1A
Ringlet 105x3 MVQ (local control)	62 732 390	-	-
Ringlet 180x3 AS 568 B/BS 1806 (UMR 1PA)	62 732 155	-	-
Ringlet 202,79x3,53 AS 568 B/BS 1806 (UMR 2PA)	62 732 156	-	-
Steering ring 28 (UMR 1PA) – to temperature -25°C	STN 029295 62 732 255	-	-
Steering ring 28x35,6x4,2 (UMR 1PA) – to temperature -50°C	62 732 391	-	-
Ring 36x28 MVQ (UMR 1PA) – to temperature -50°C	STN 029280.9 62 732 338	-	-
Steering ring 40 (UMR 2PA) - to temperature -25°C	62 732 164	-	-
Steering ring 40x48,8x6,3 (UMR 2PA) – to temperature -50°C	62 732 158		
O-ring 44,12x2,62 (UMR 2PA) – to temperature -50°C	62 732 157		
Ring 50x40 MVQ (UMR 2PA) – to temperature -50°C	STN 029280.9 62 732 404	-	-

Warning: By supplying spare parts, the manufacturer is not responsible for damages caused by their disassembly and assembly. Installation, replacement of spare parts must be performed by authorized, qualified personnel.



The disassemble of EA for the purpose of repair is possible only for the manufacturer!

7. Enclosures

7.1 Wiring diagrams

Wiring diagrams UMR XPA for single phase supply

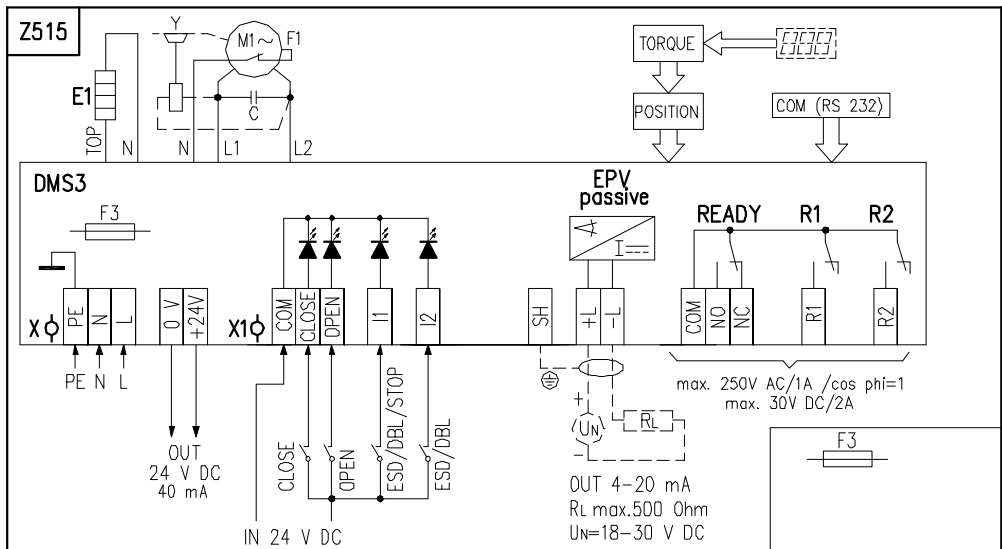
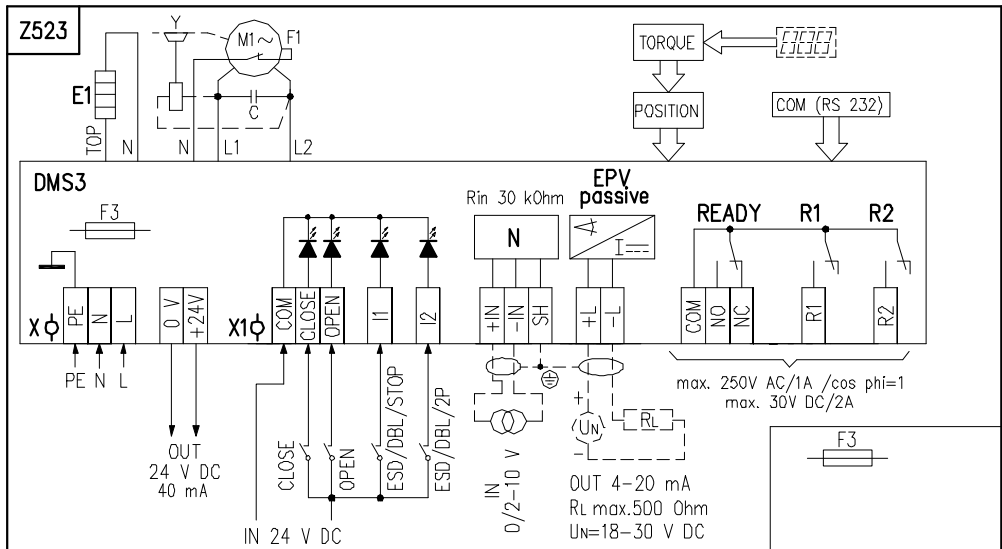
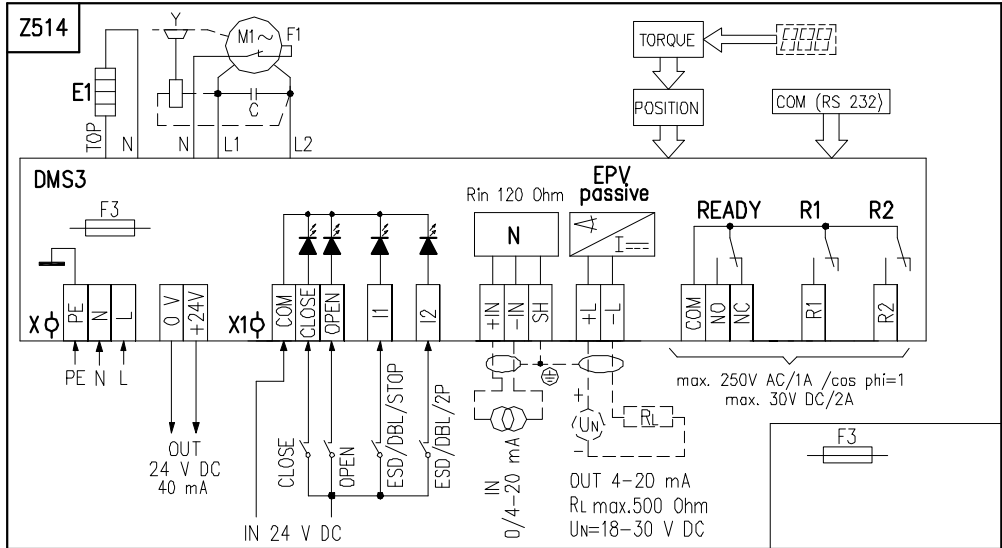

Wiring diagrams EA UMR 1PA for three phase supply

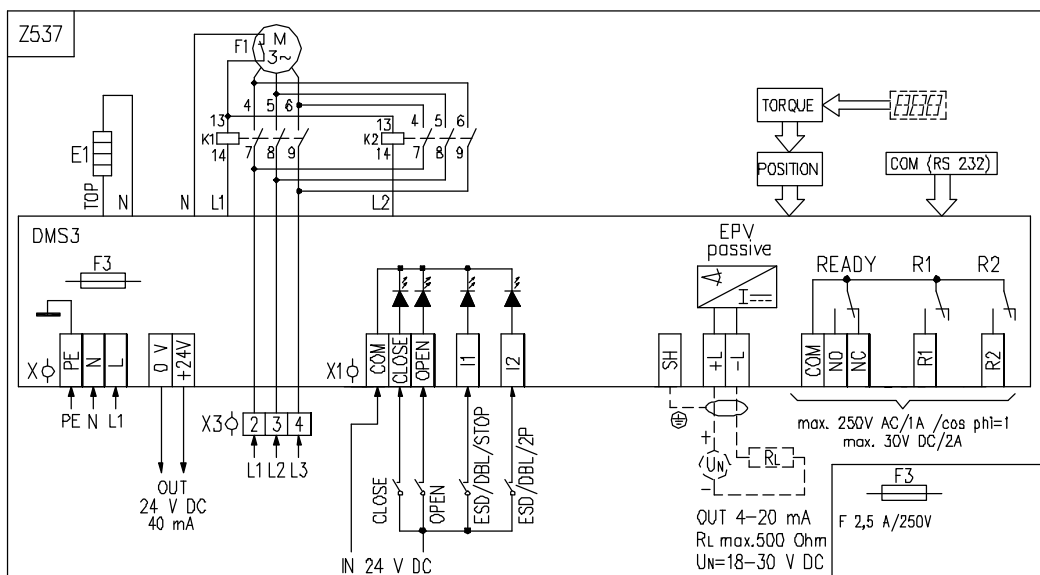
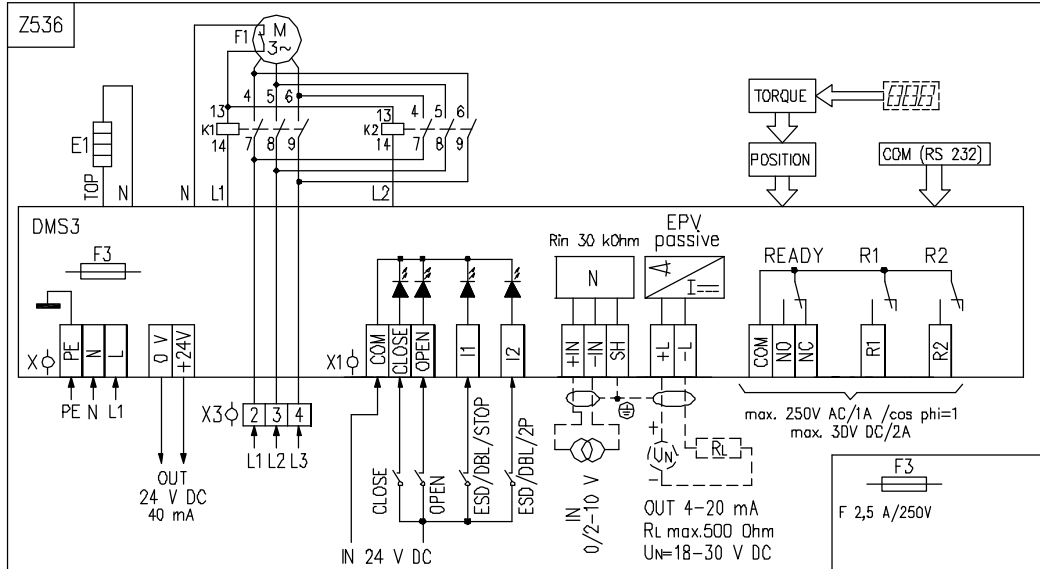
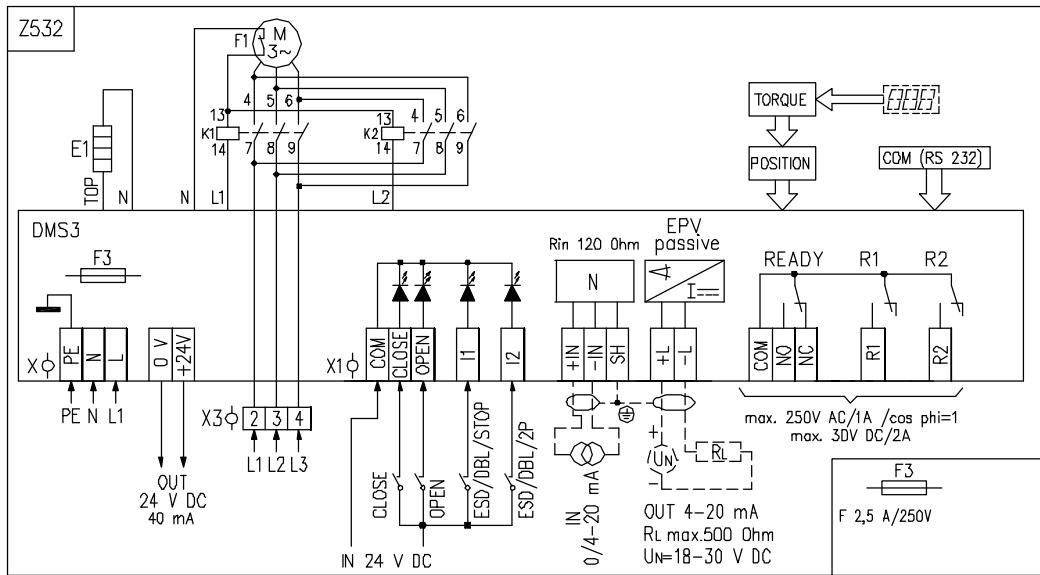

Wiring diagrams EA UMR 2PA for three phase supply, reverse contactors

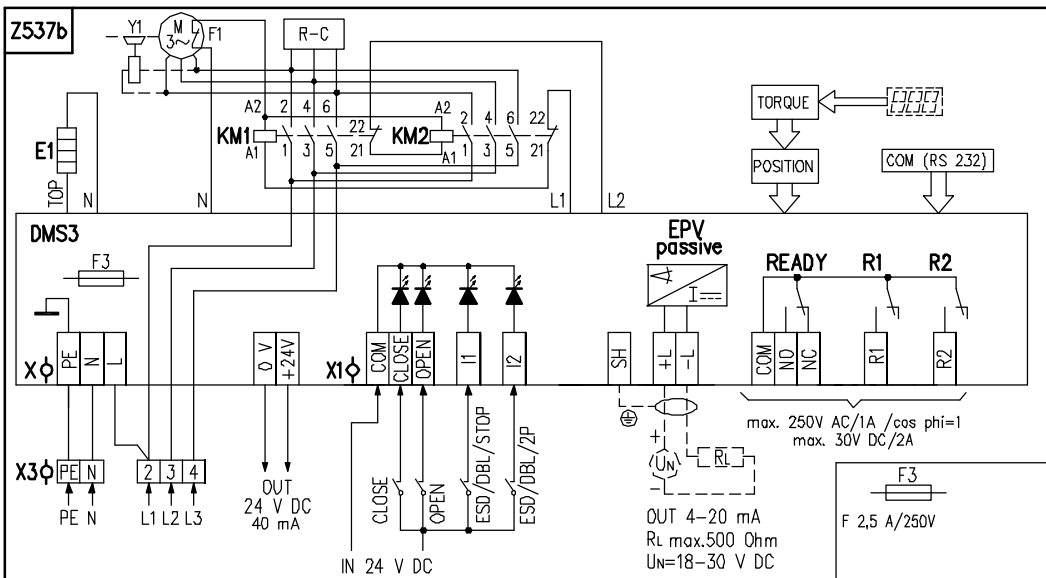
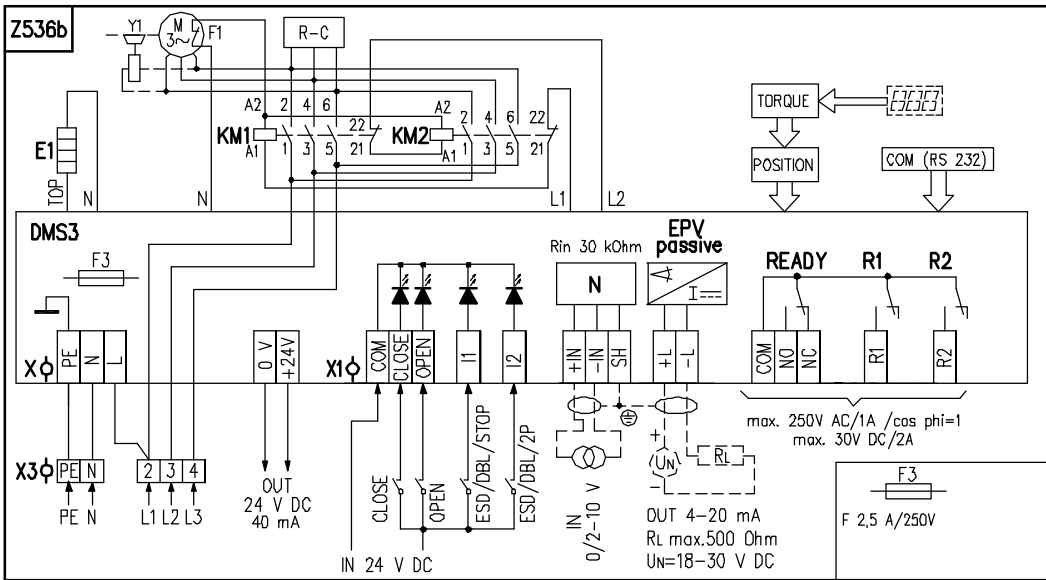
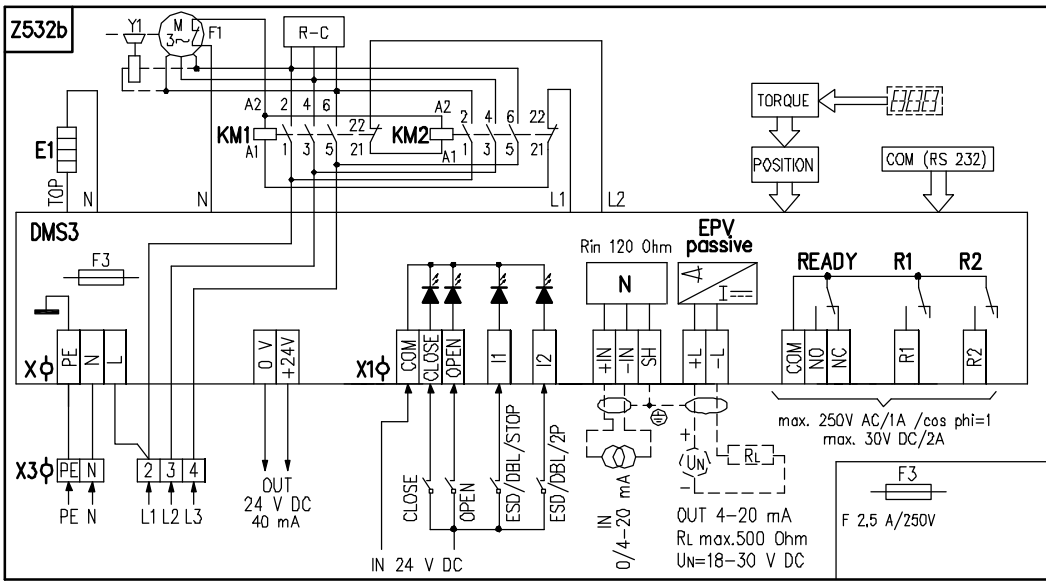

Wiring diagrams EA UMR 2PA – for three phase supply with-contactless switching

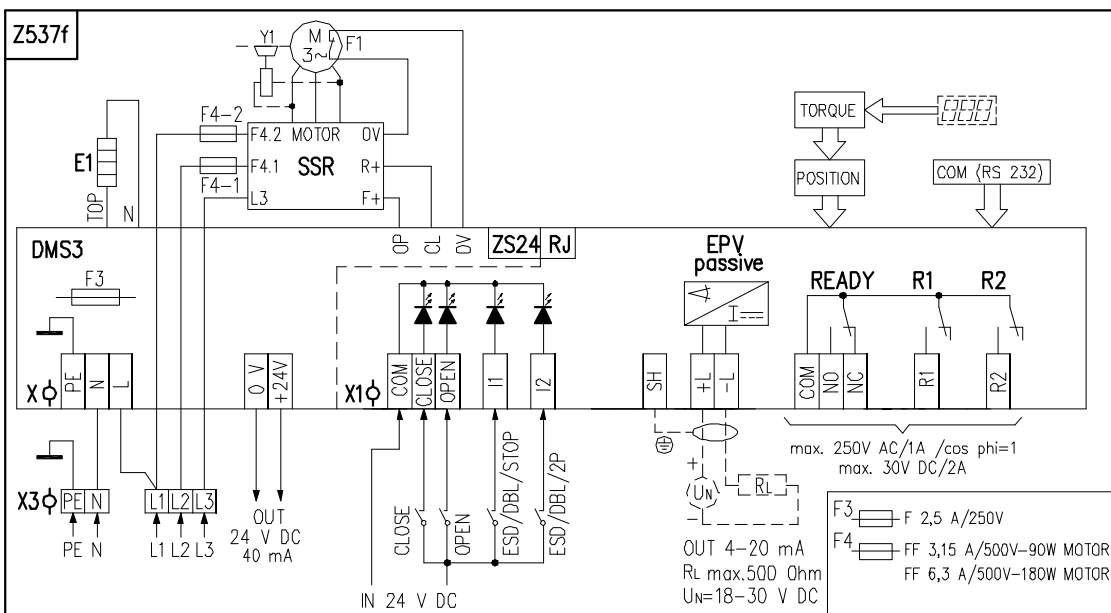
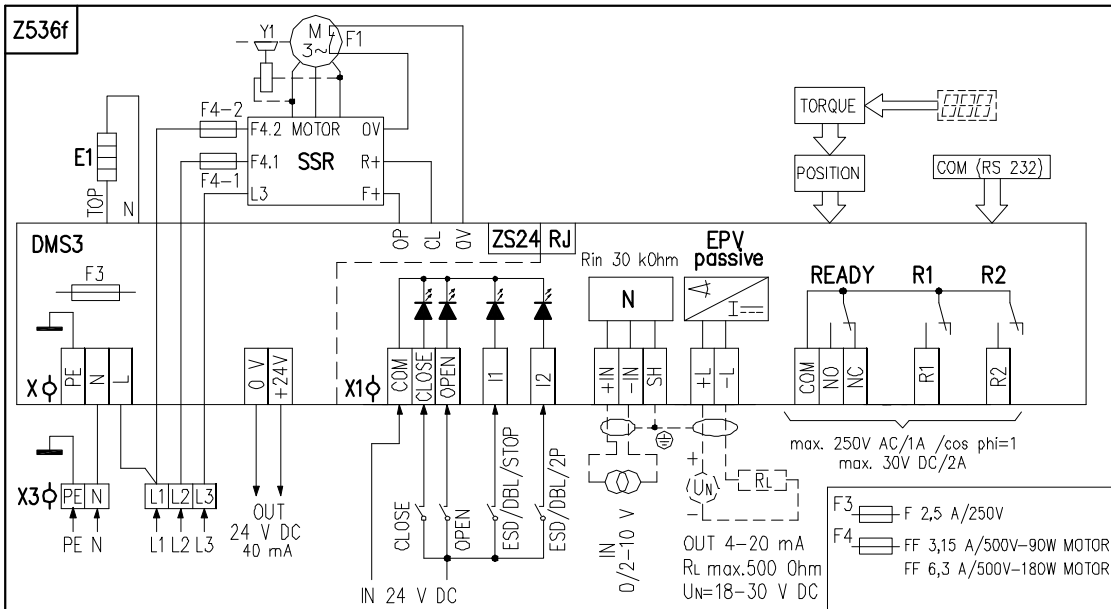
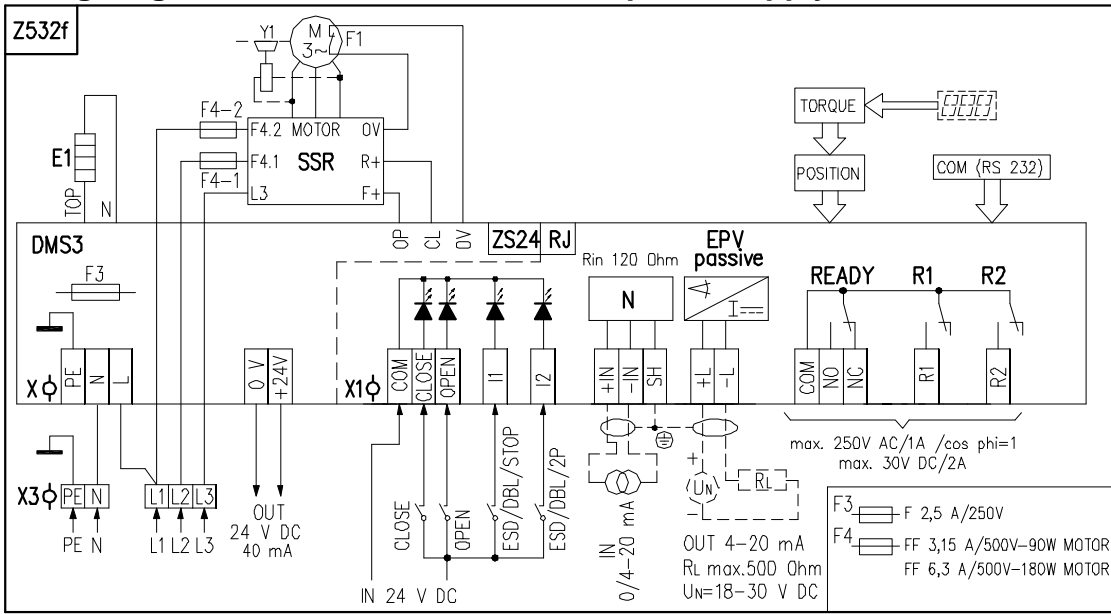

Wiring diagrams EA UMR 1PA – for 24 V AC/DC, UMR 2PA – for 24 V DC

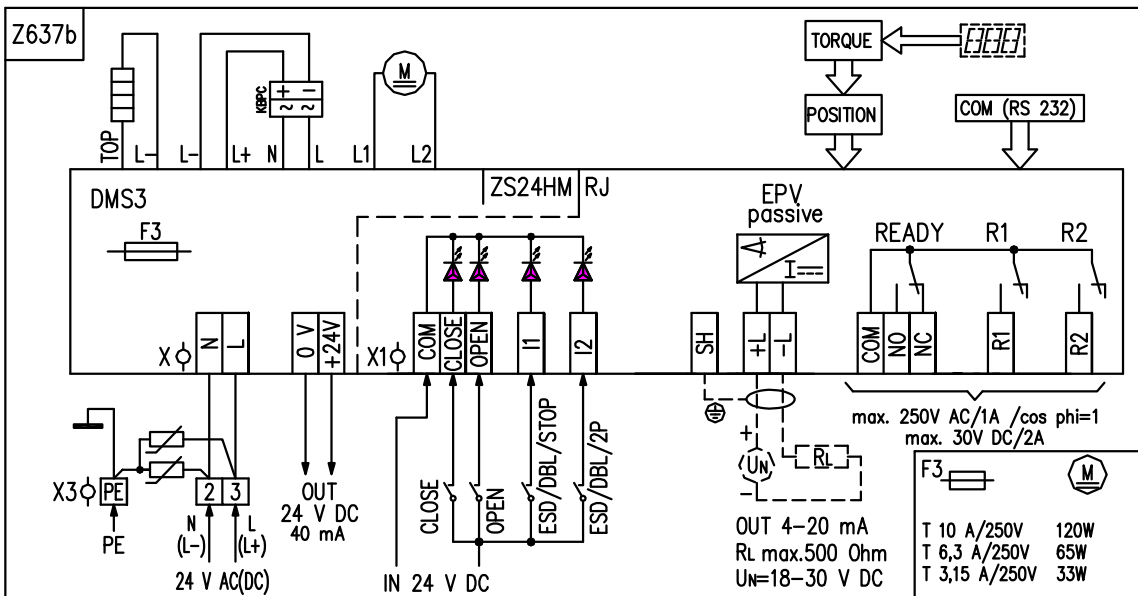
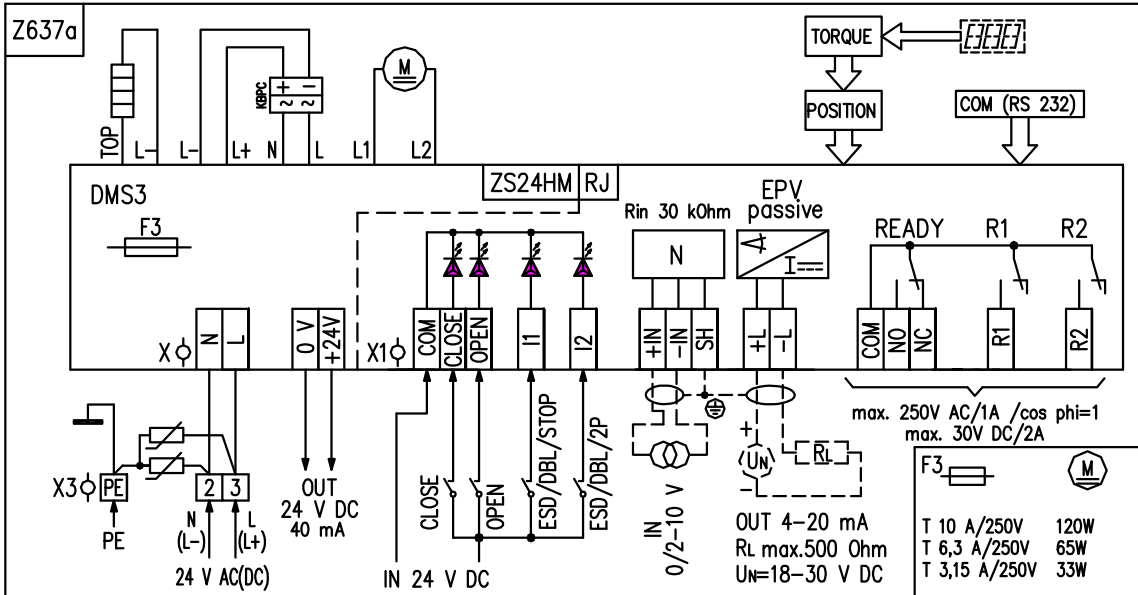
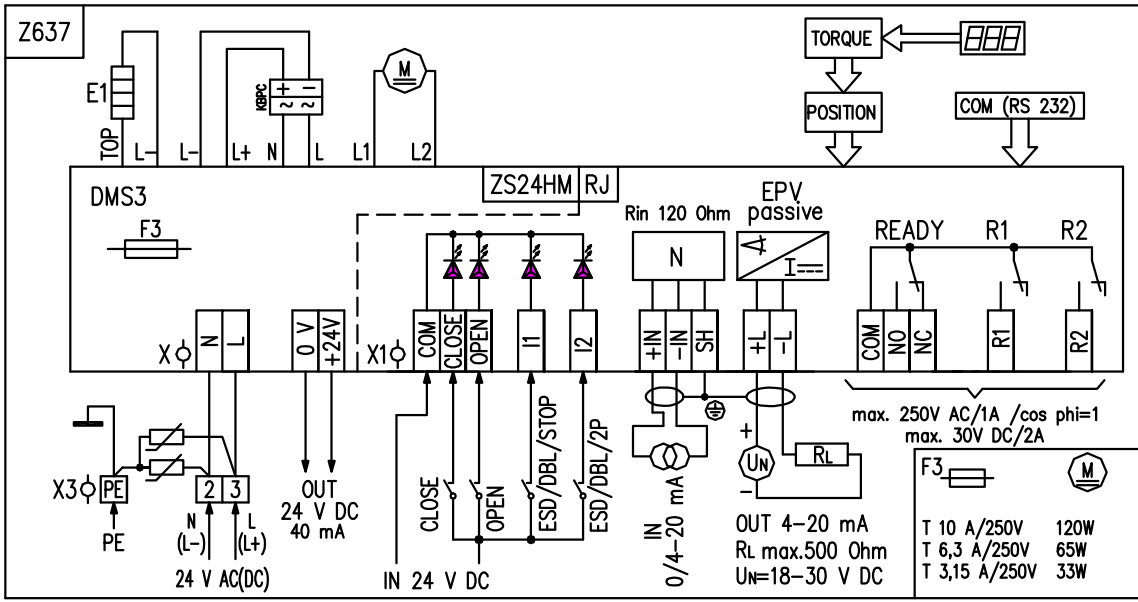

Wiring diagrams EA UMR XPA– single - phase supply – for ambient temperature -60°C do +40°

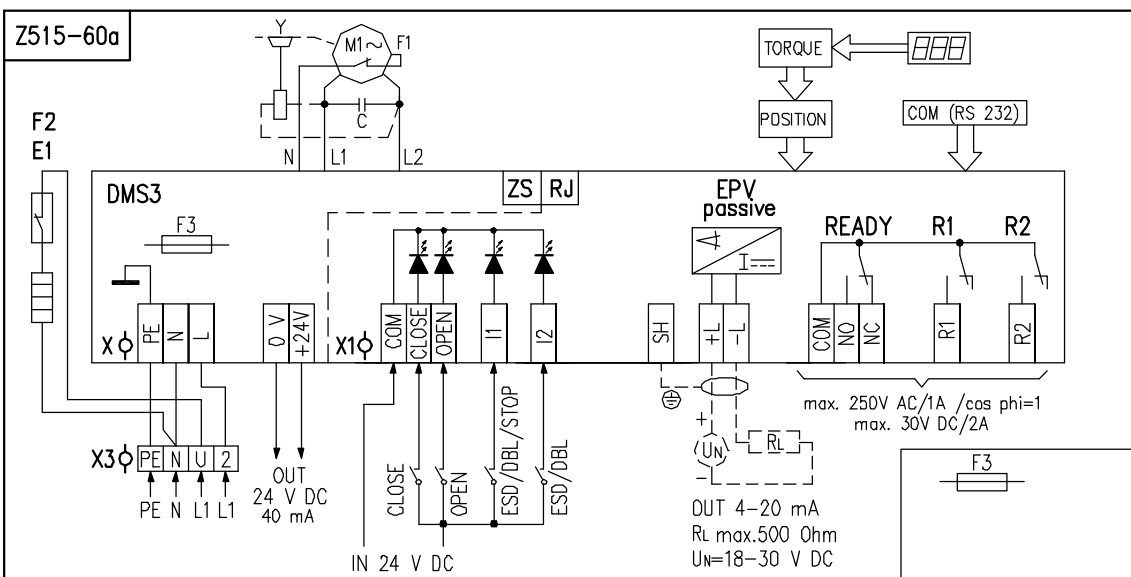
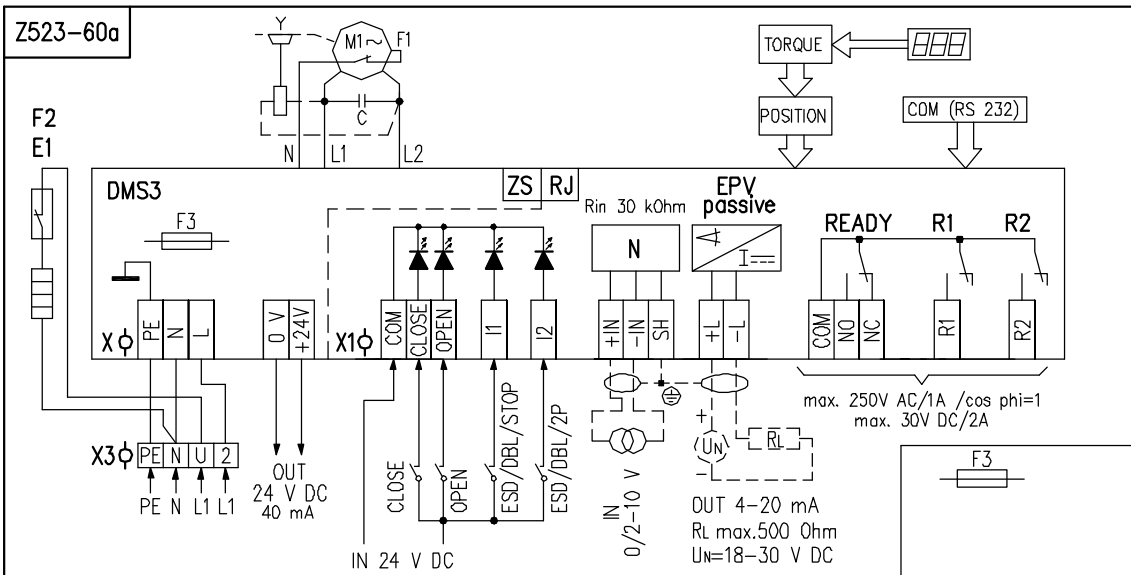
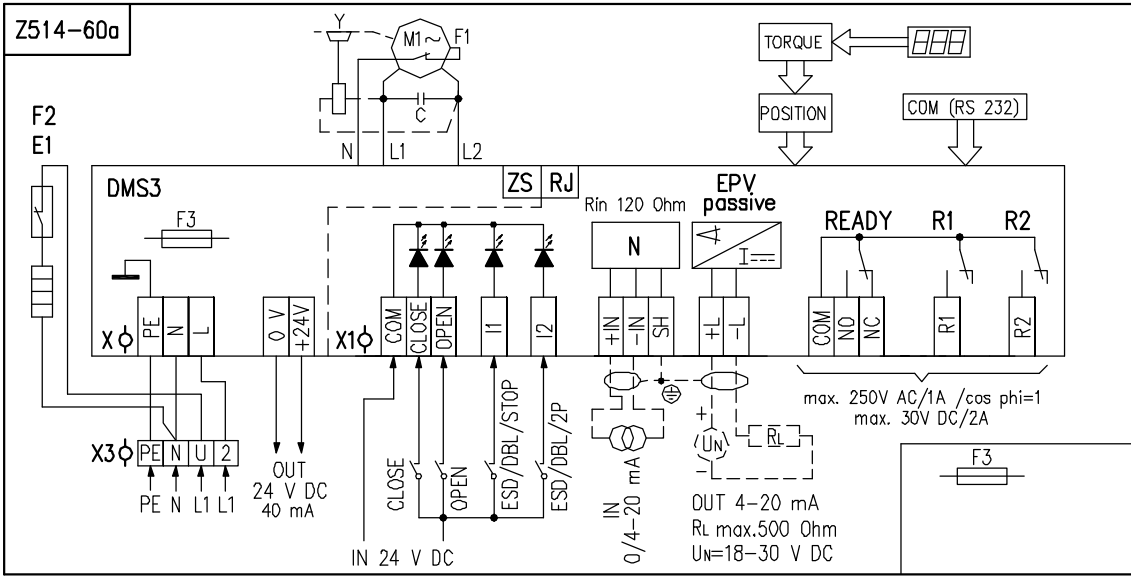

Wiring diagrams EA UMR 1PA- three - phase supply – for ambient temperature -60°C do +40°

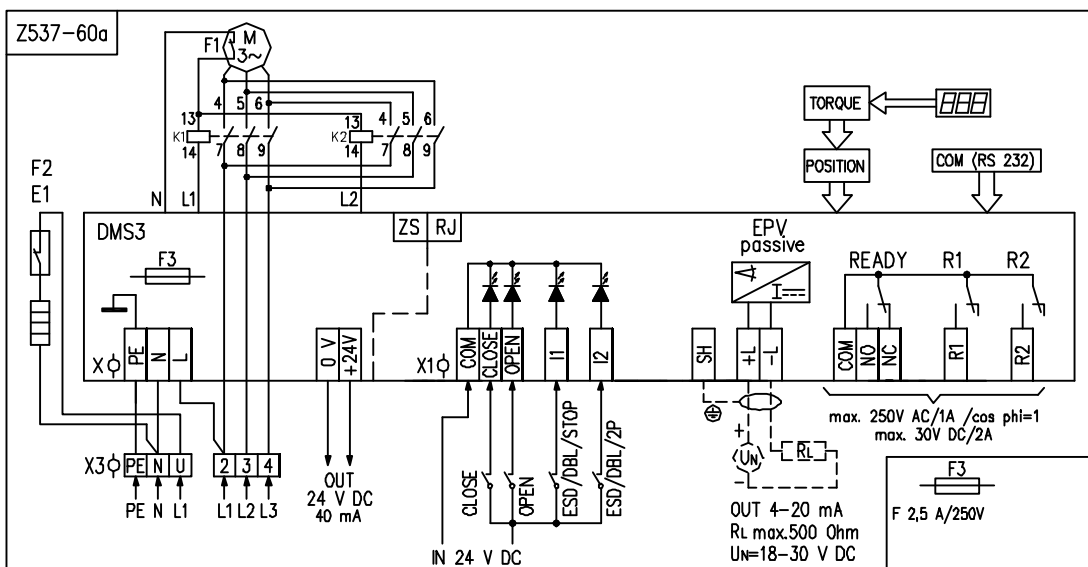
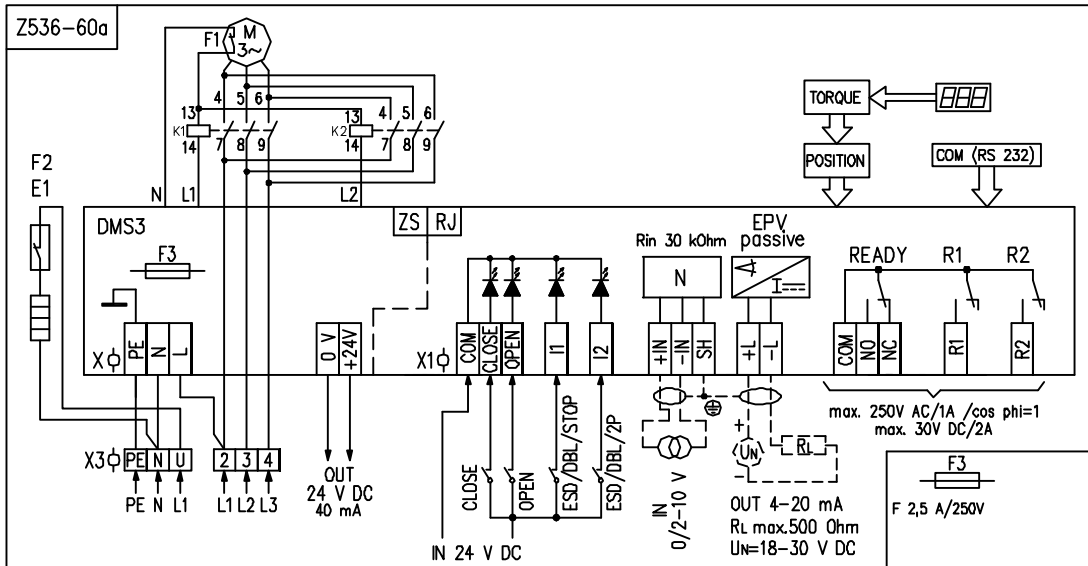
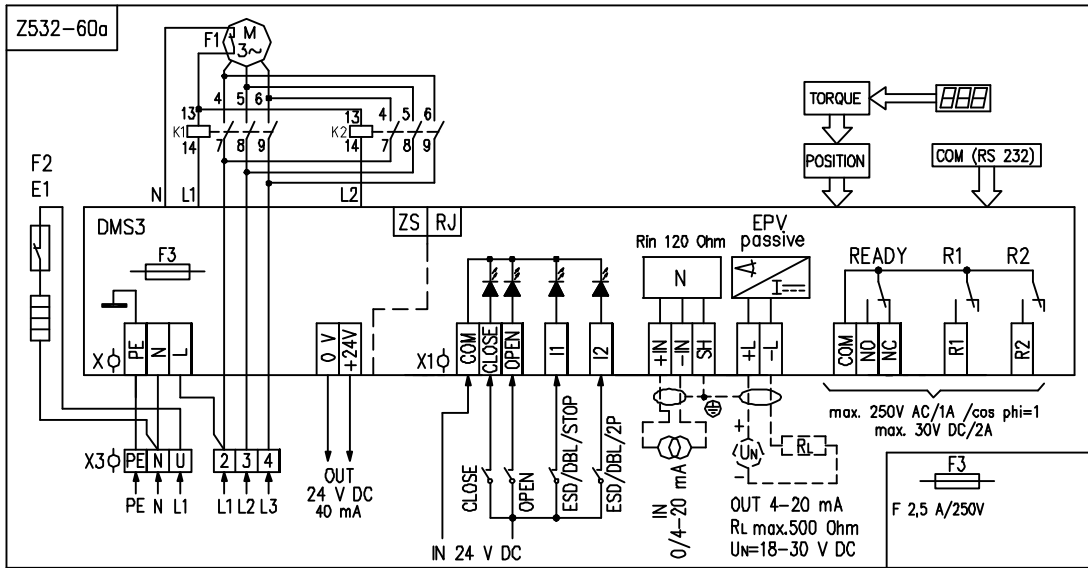

Wiring diagrams EA UMR 2PA– three - phase supply, reserve contactors – for ambient temperature -60°C do $+40^{\circ}$

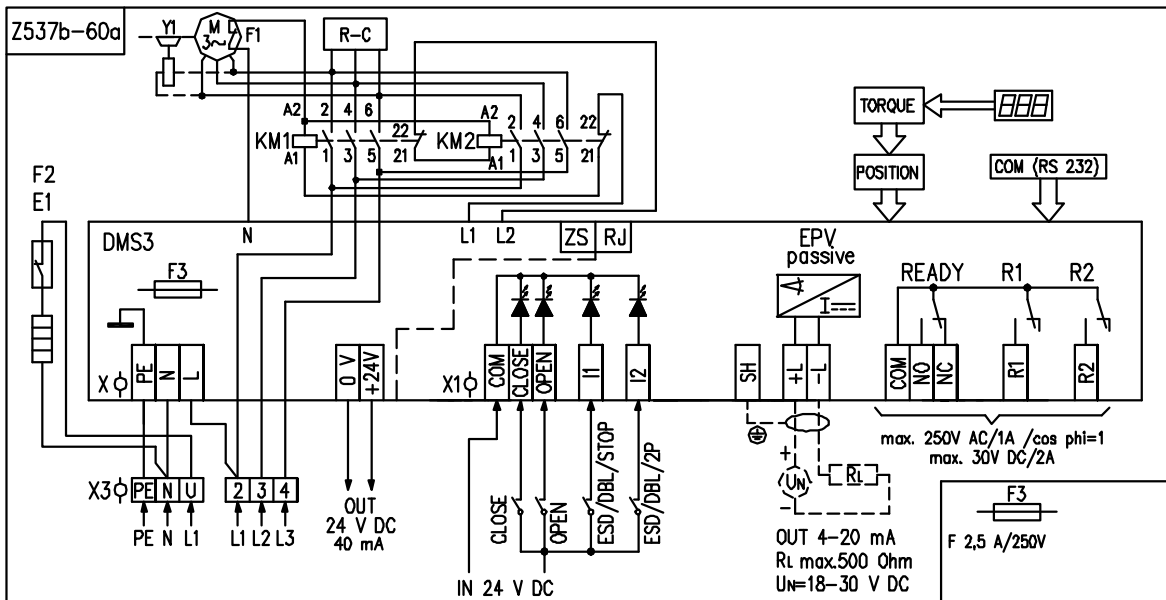
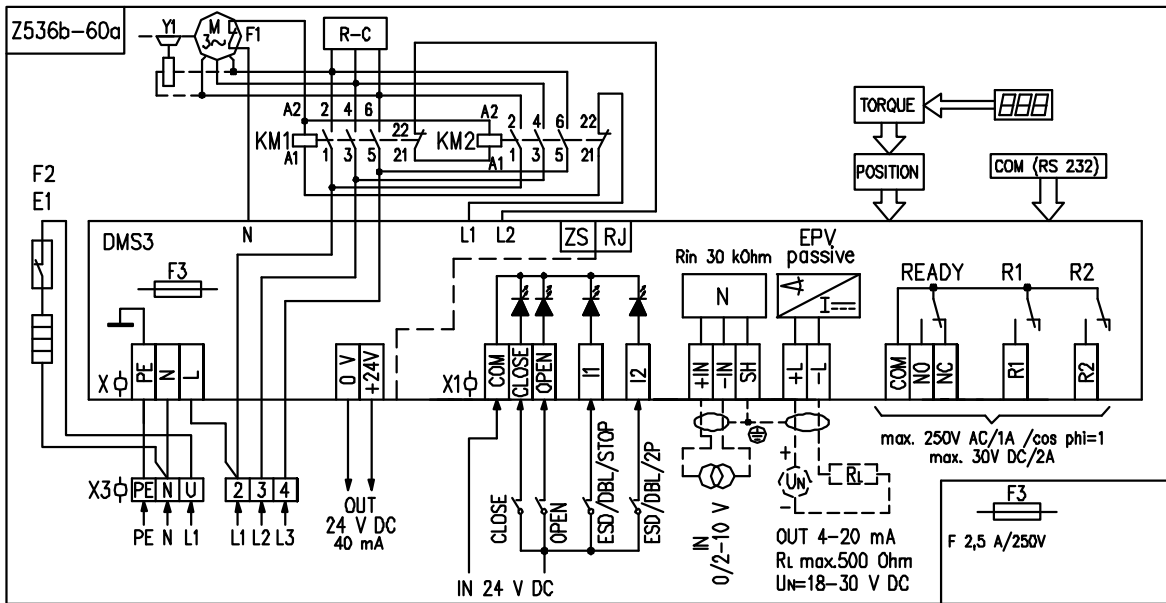
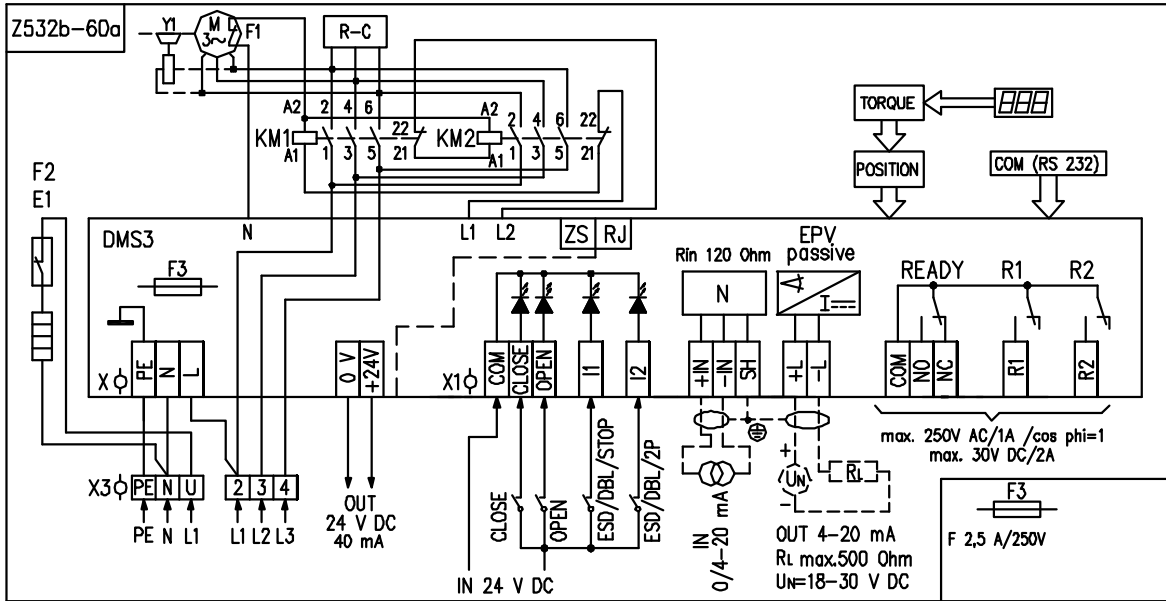

Wiring diagrams EA UMR 2PA – three - phase supply, with contactless switching – for ambient temperature -60°C do +40°

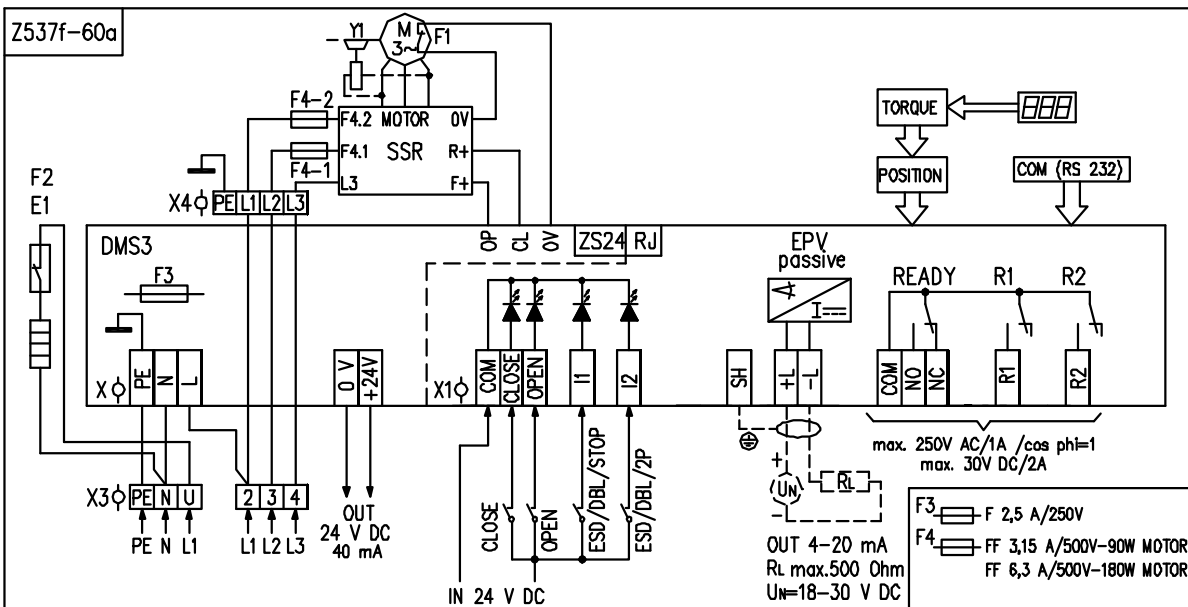
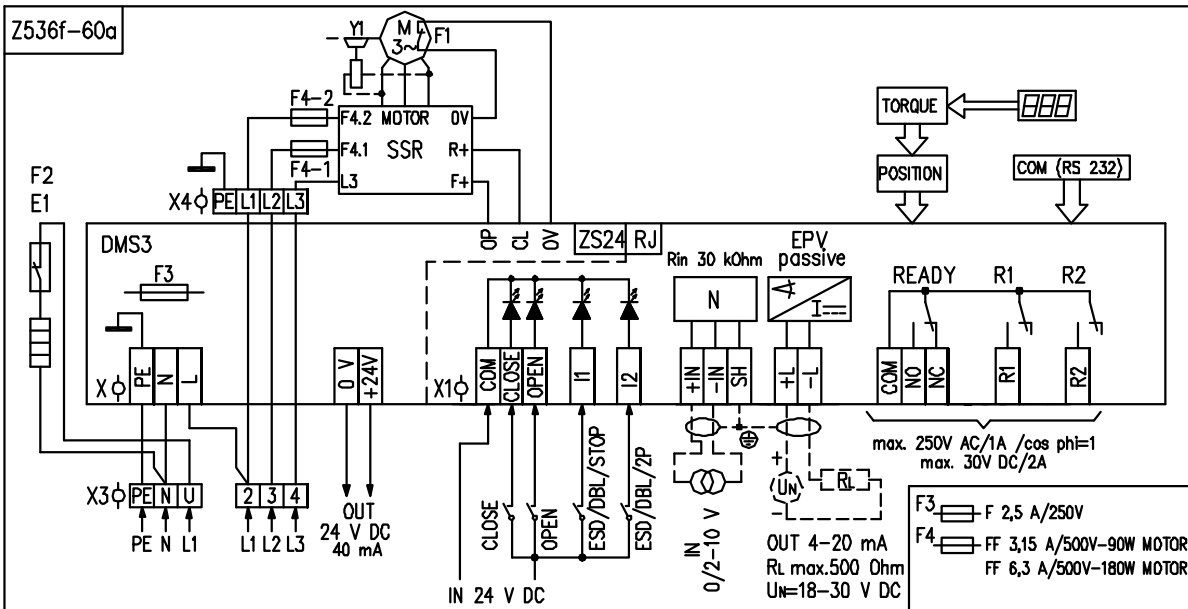
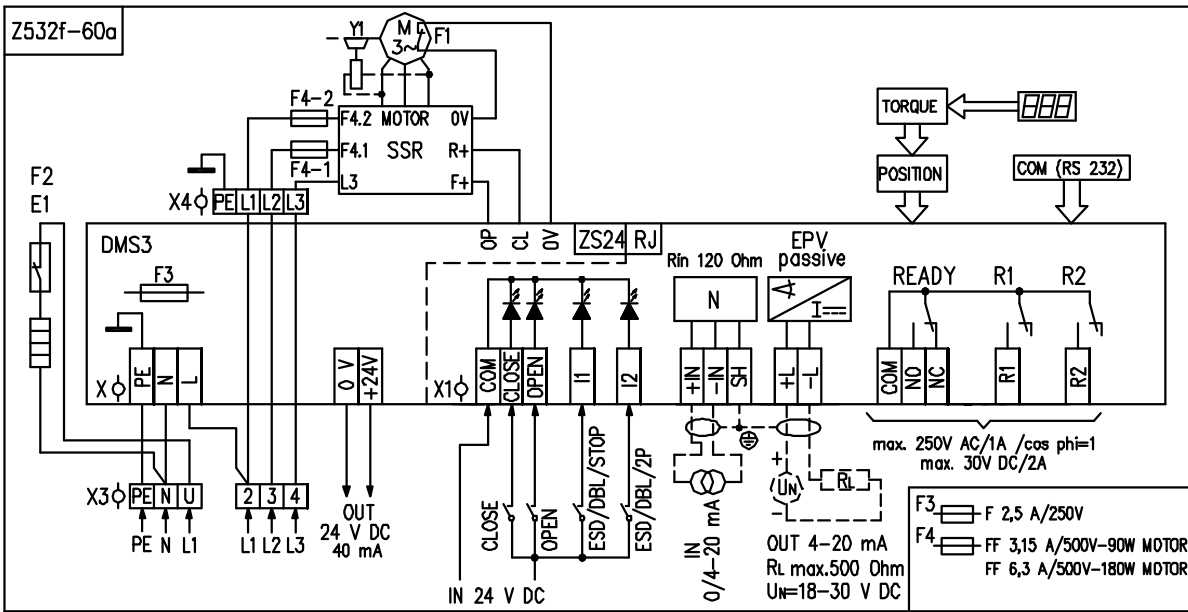

Wiring diagrams EA UMR 1PA – for 24V AC/DC, EA UMR 2PA - for 24V DC – for ambient temperature -60°C do +40°

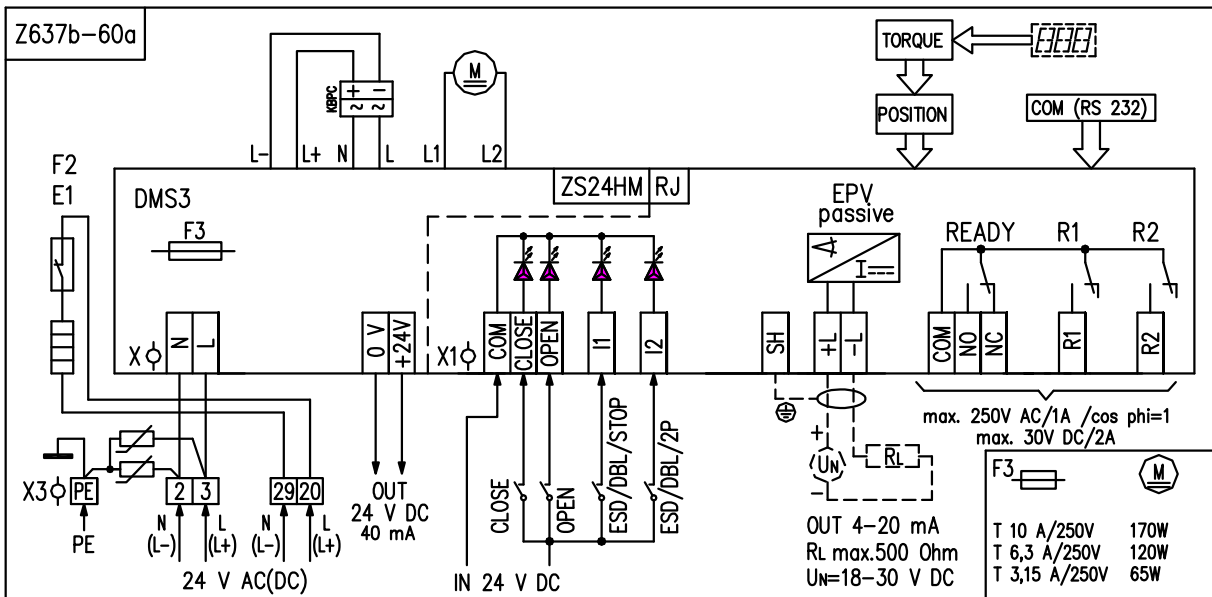
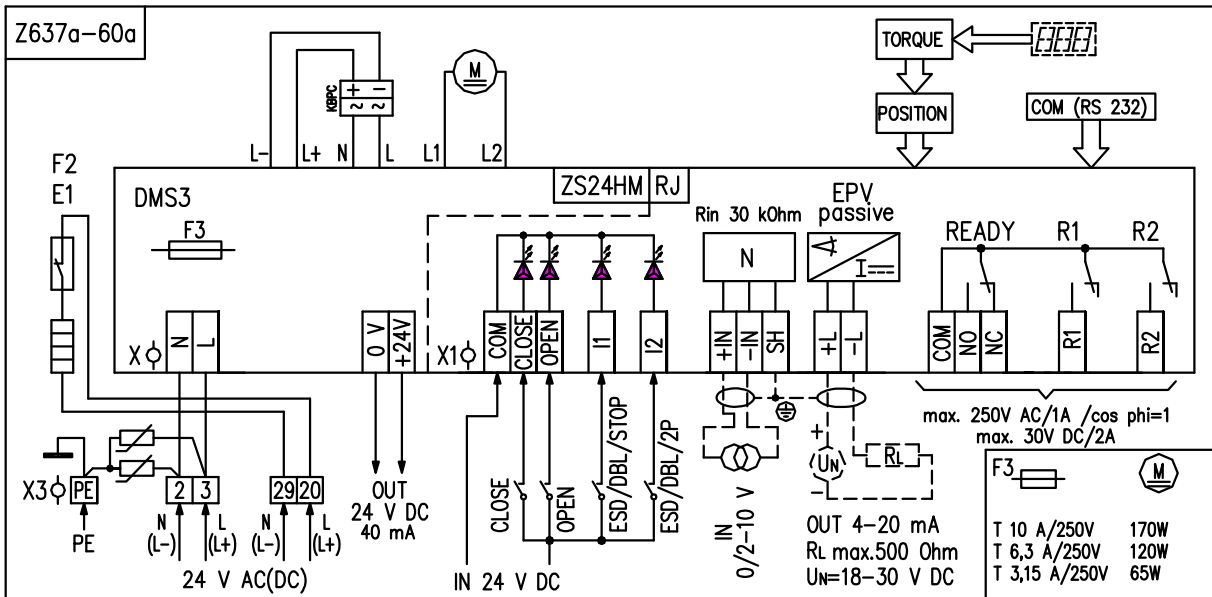
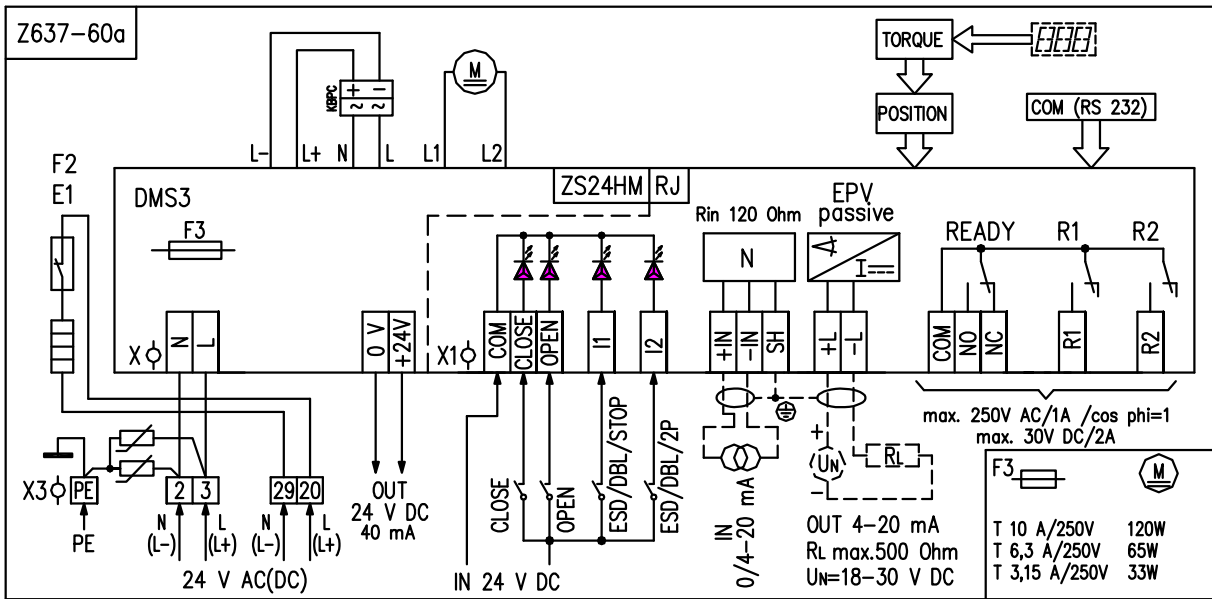

Wiring diagrams with of EA UMR XPA, electronic control with Modbus/Profibus protocol for single - phase supply

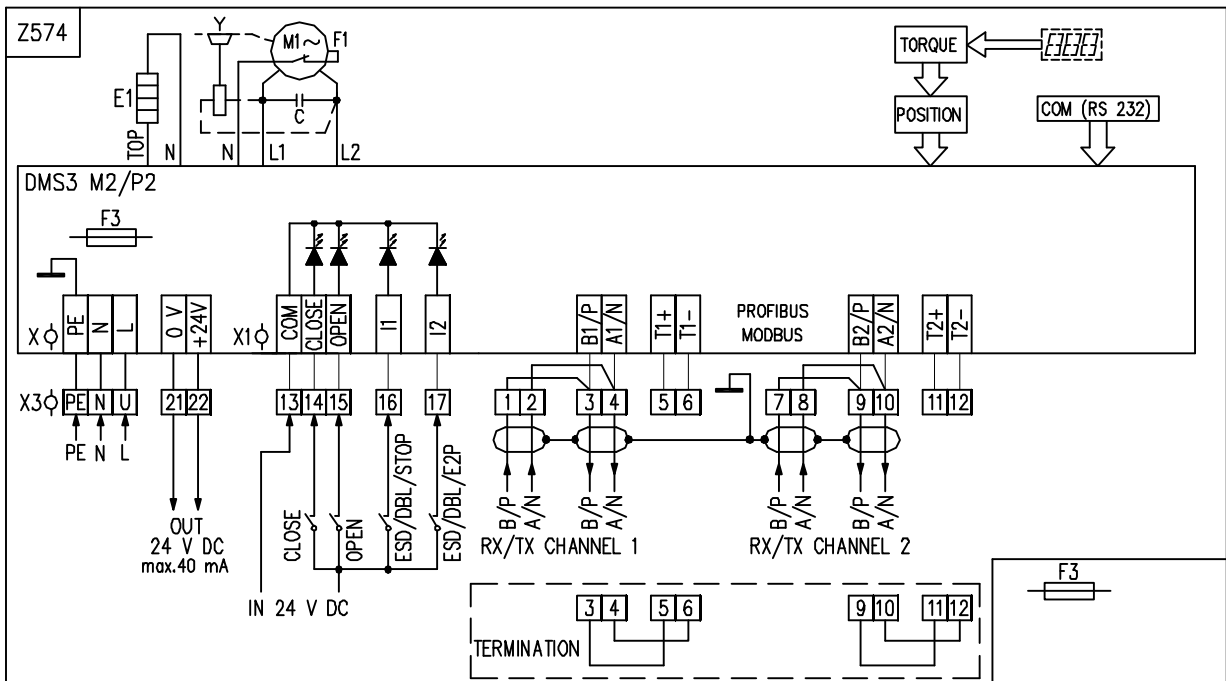
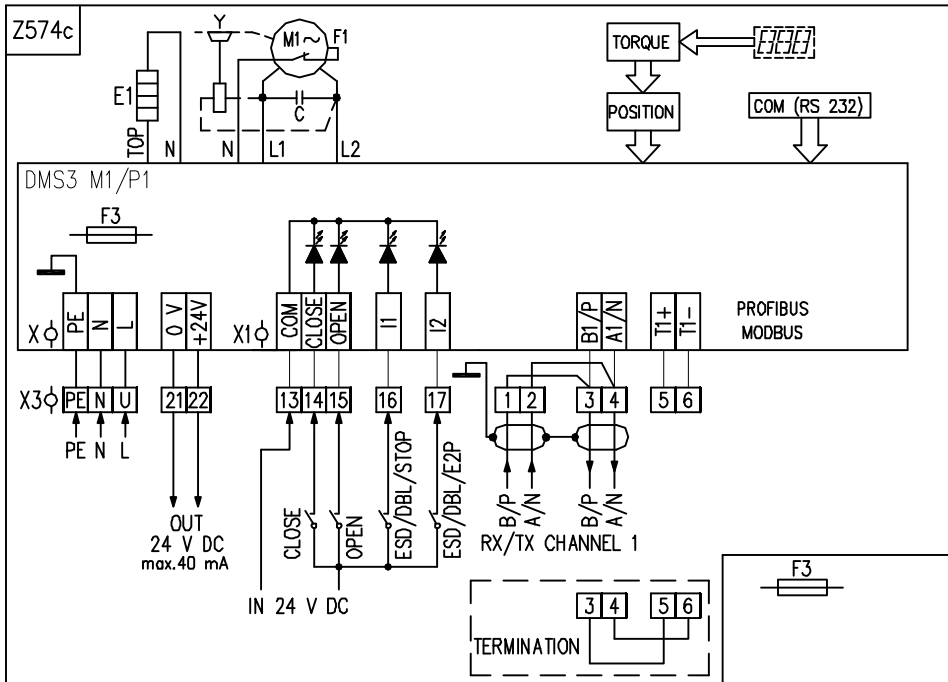

Wiring diagrams of EA UMR 1PA with DMS3 electronic control with Modbus/Profibus protocol for three - phase supply

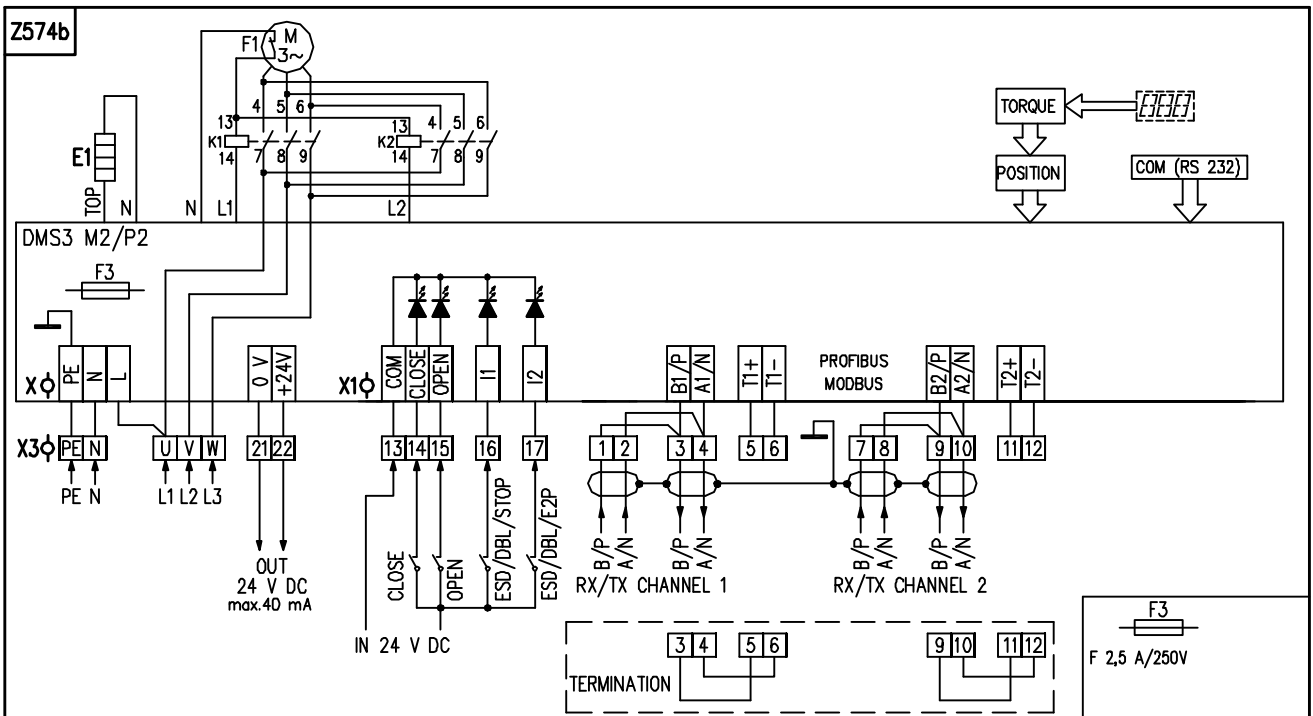
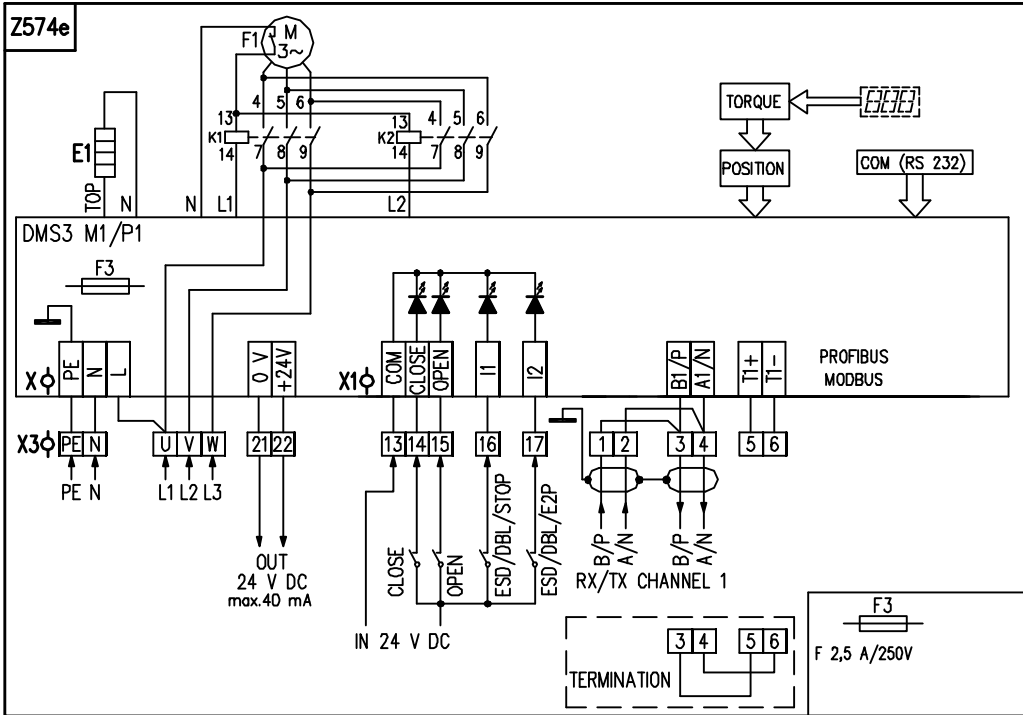

Wiring diagram of EA UMR 2PA with 3-phase electric motor, reverse contactors with communication protocol MODBUS / PROFIBUS

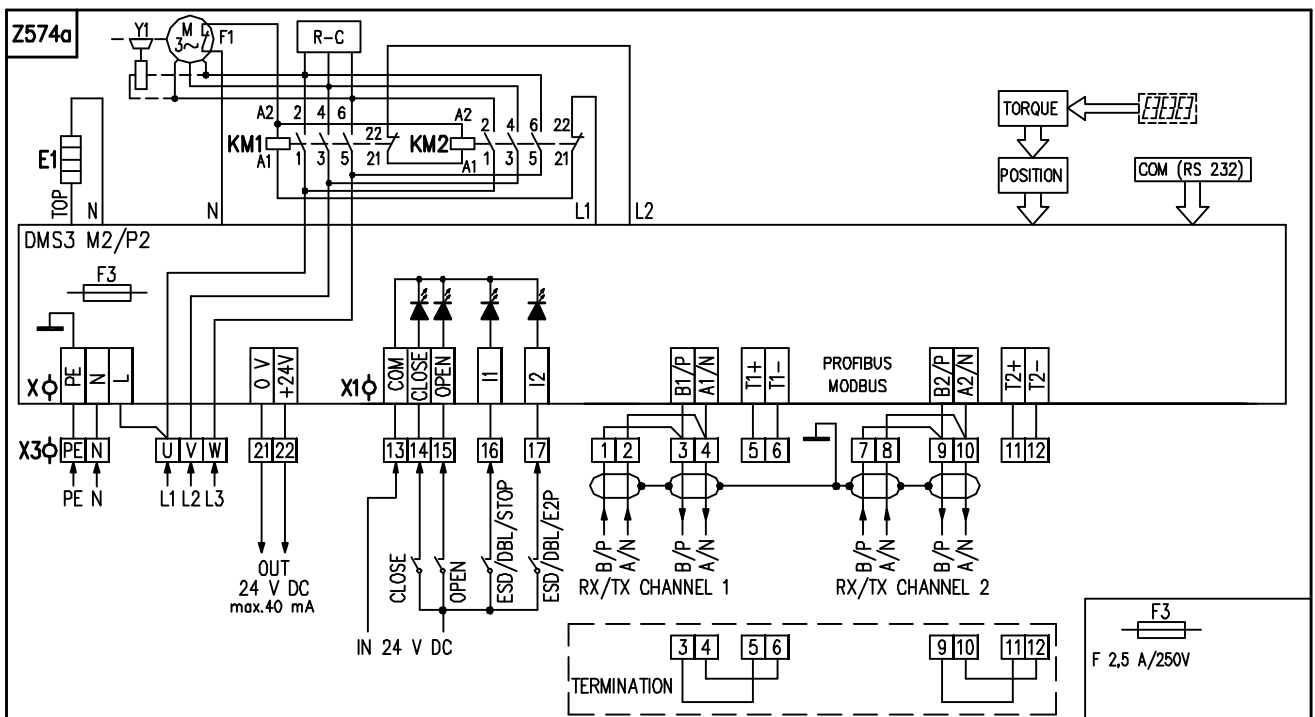
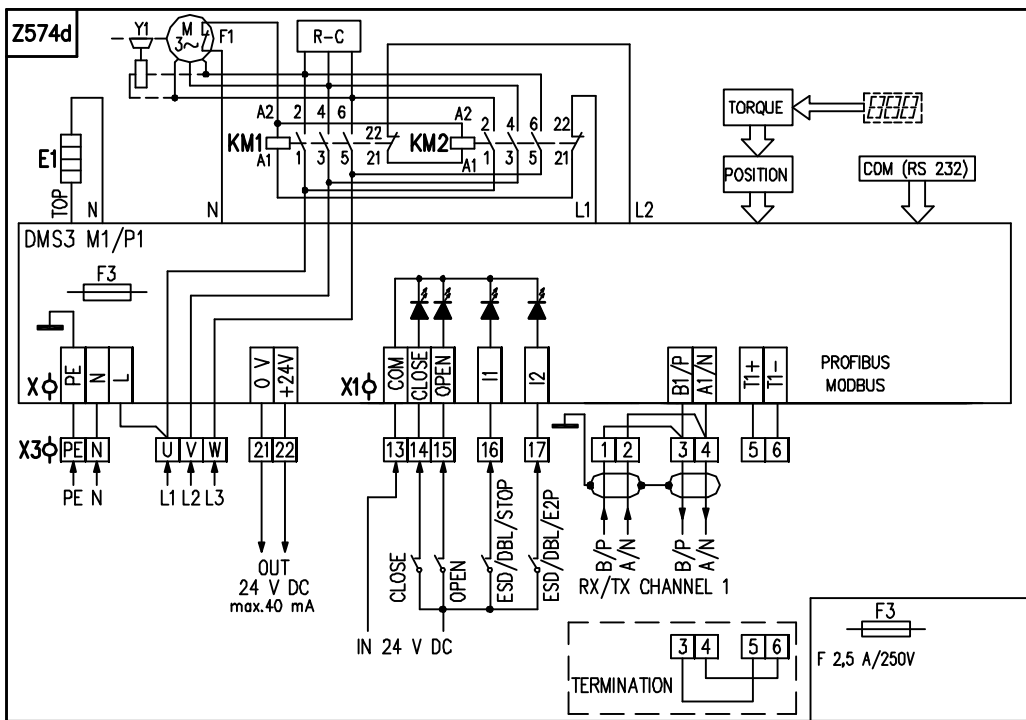

Wiring diagrams EA UMR 2PA with Modbus/Profibus protocol – for three phase supply, with-contactless switching

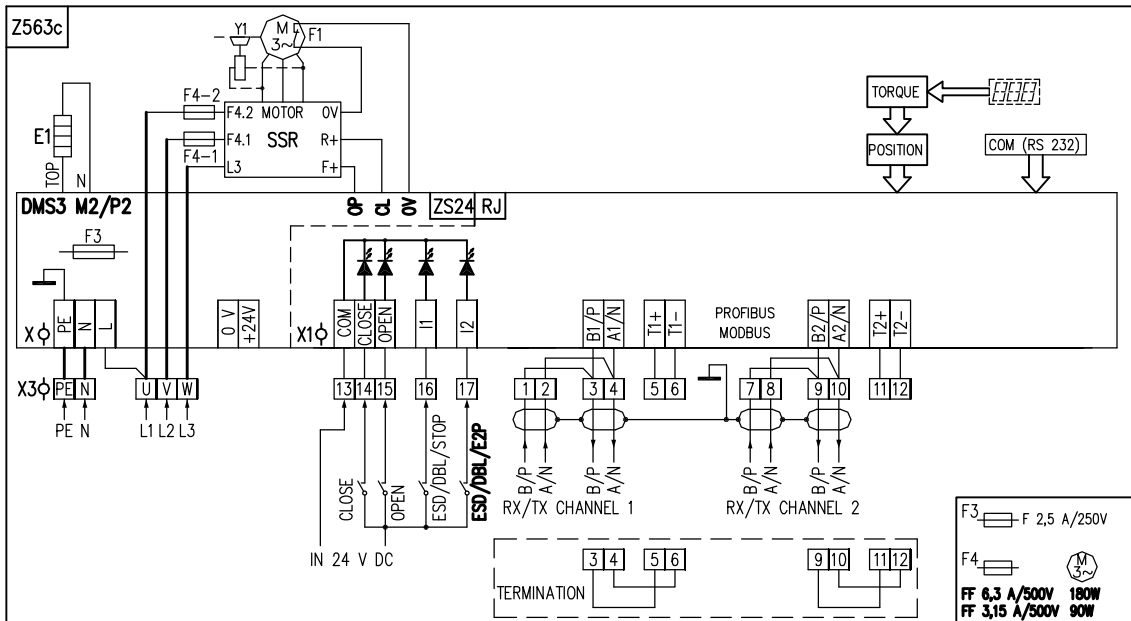
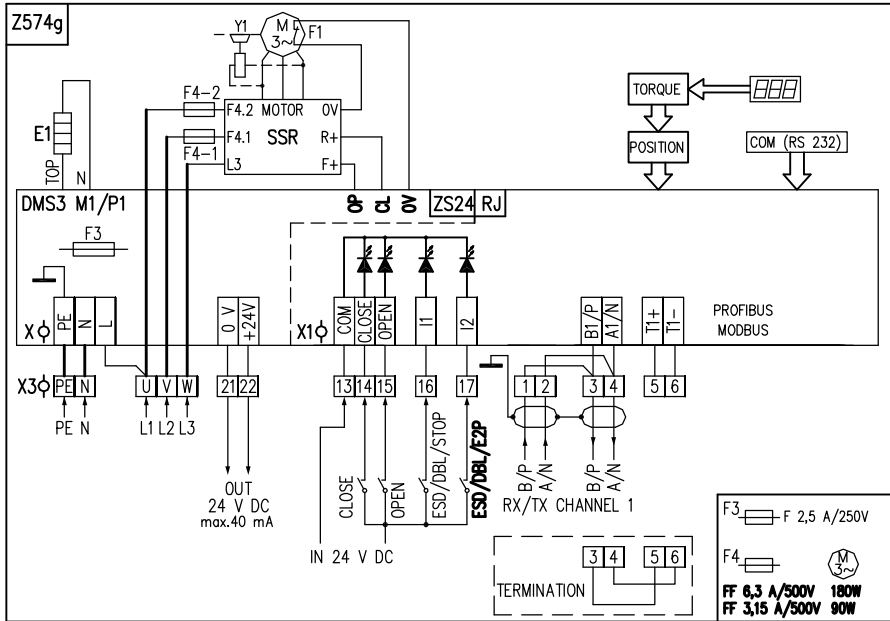

Wiring diagrams EA UMR 1PA– for 24V AC/DC, EA UMR 2PA - for 24V DC, electronic control with Modbus/Profibus

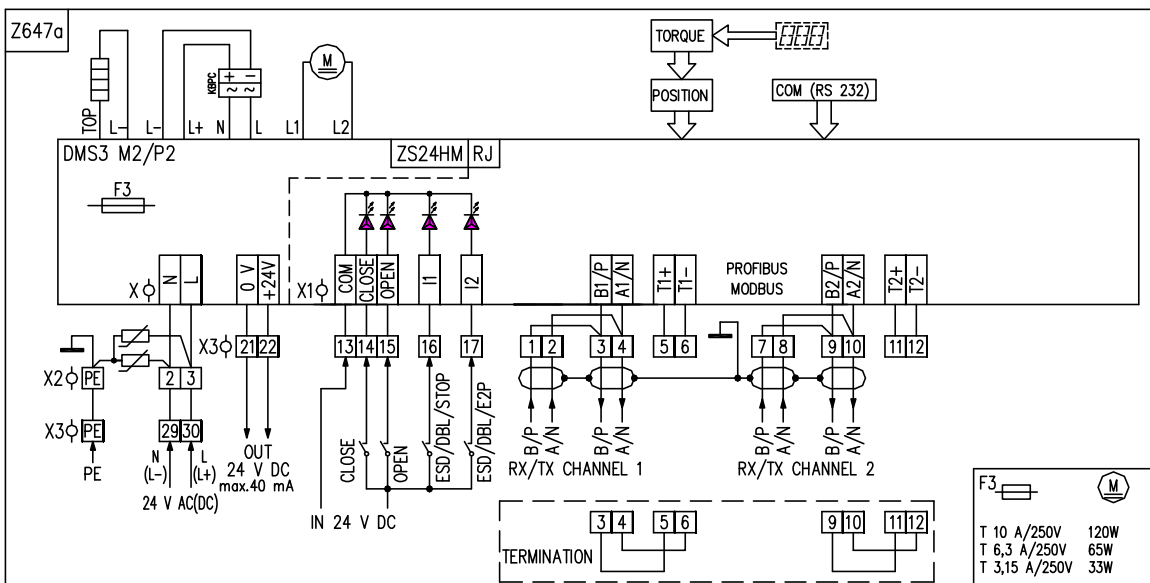
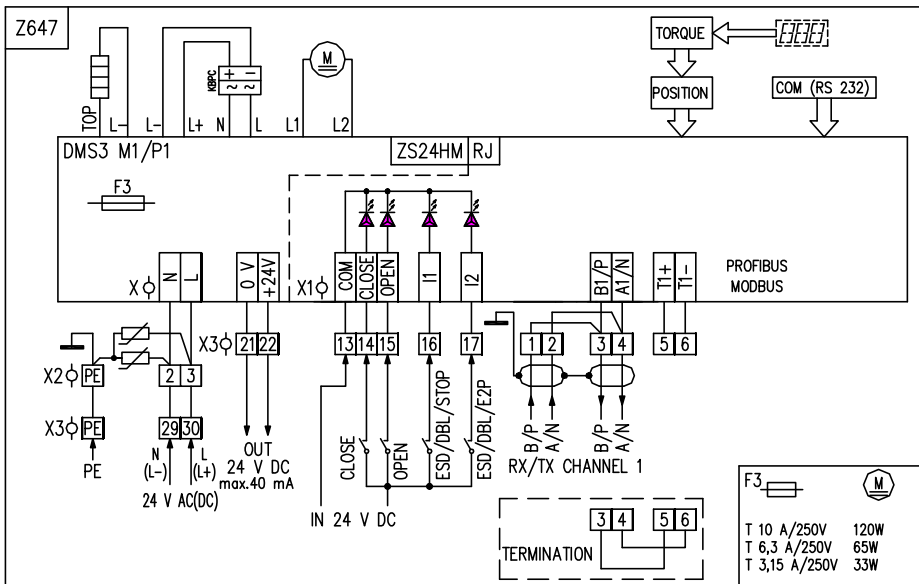

Wiring diagrams with of EA UMR XPA electronic control with Modbus/Profibus protocol for single - phase supply – for ambient temperature -60°C do +40°

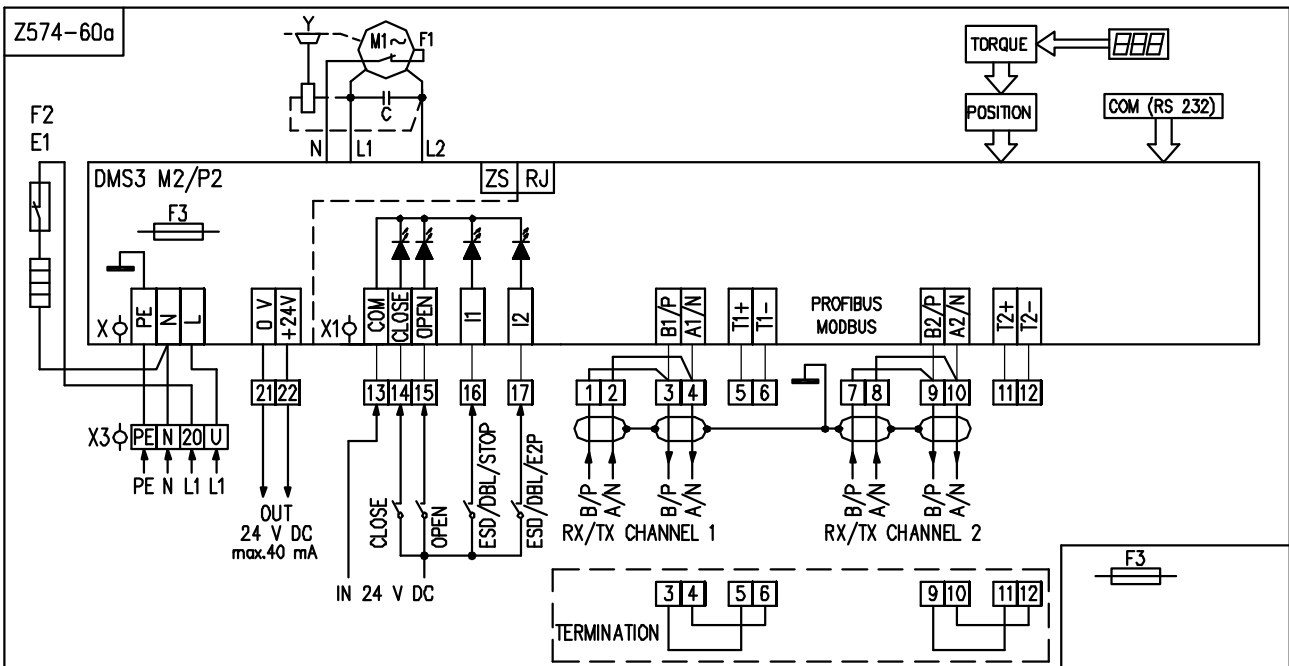
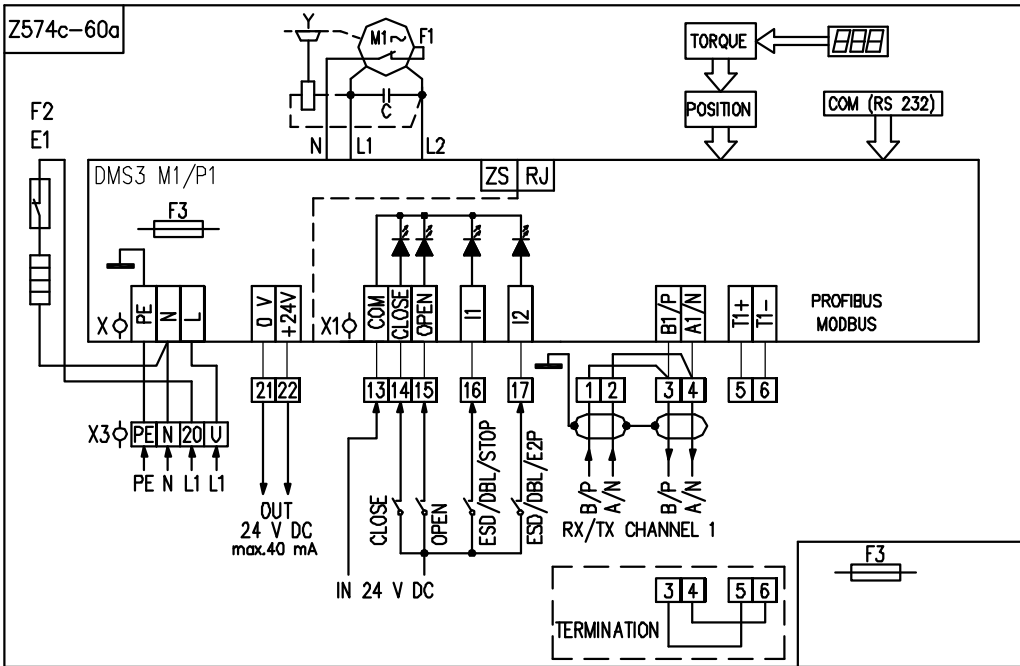

Wiring diagrams EA UMR 1PA – for 24 V AC/DC, UMR 2PA – for 24 V DC, electronic control with Modbus/Profibus protocol for single - phase supply – for ambient temperature - 60°C do +40°

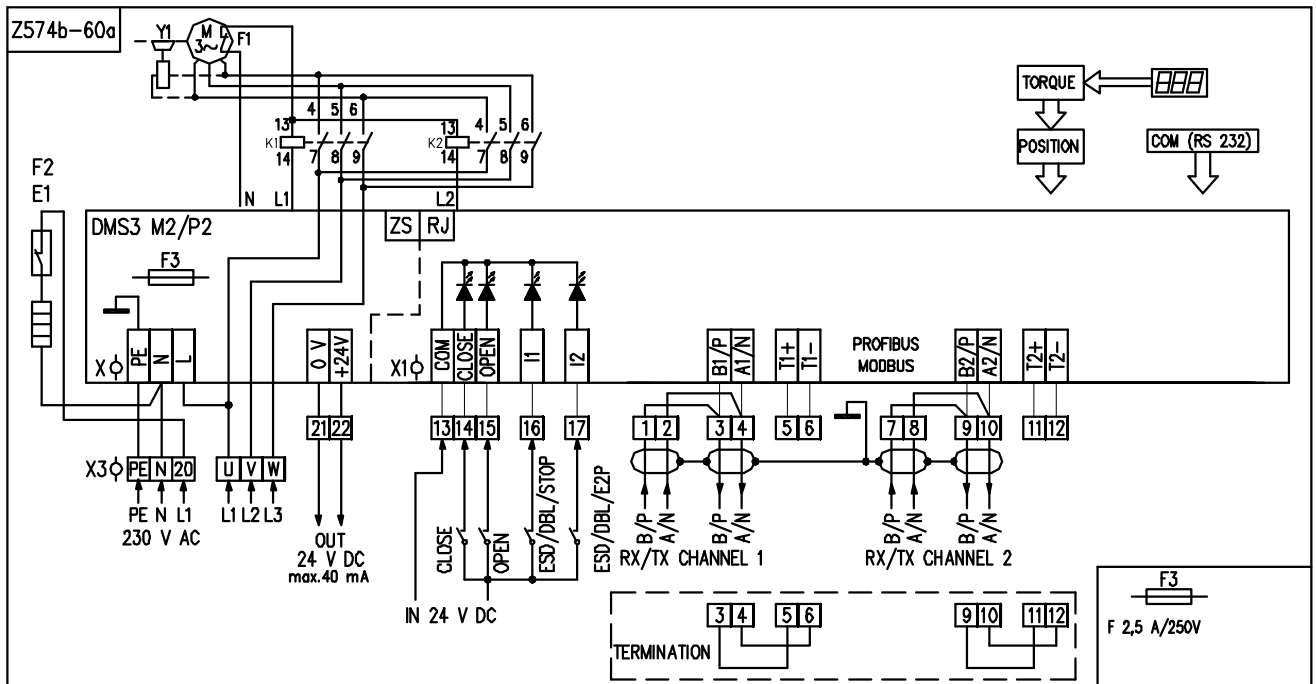
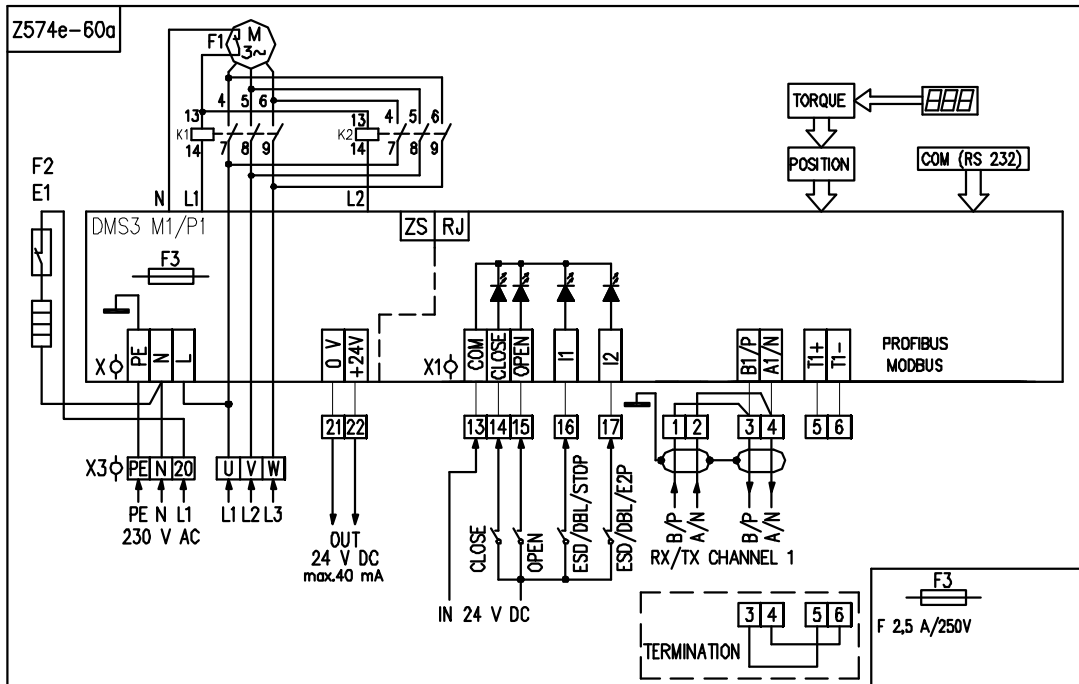

Wiring diagrams with of EA UMR 2PA electronic control with Modbus/Profibus protocol for single - phase supply – for ambient temperature -60°C do +40°

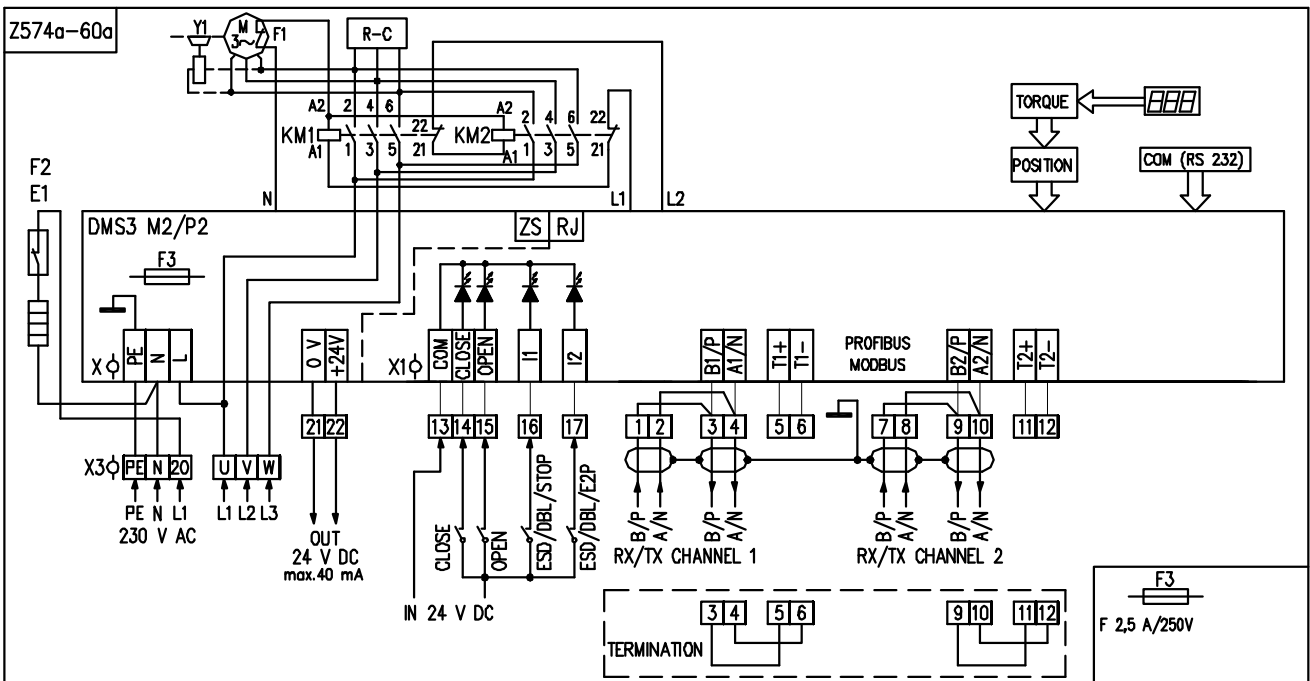
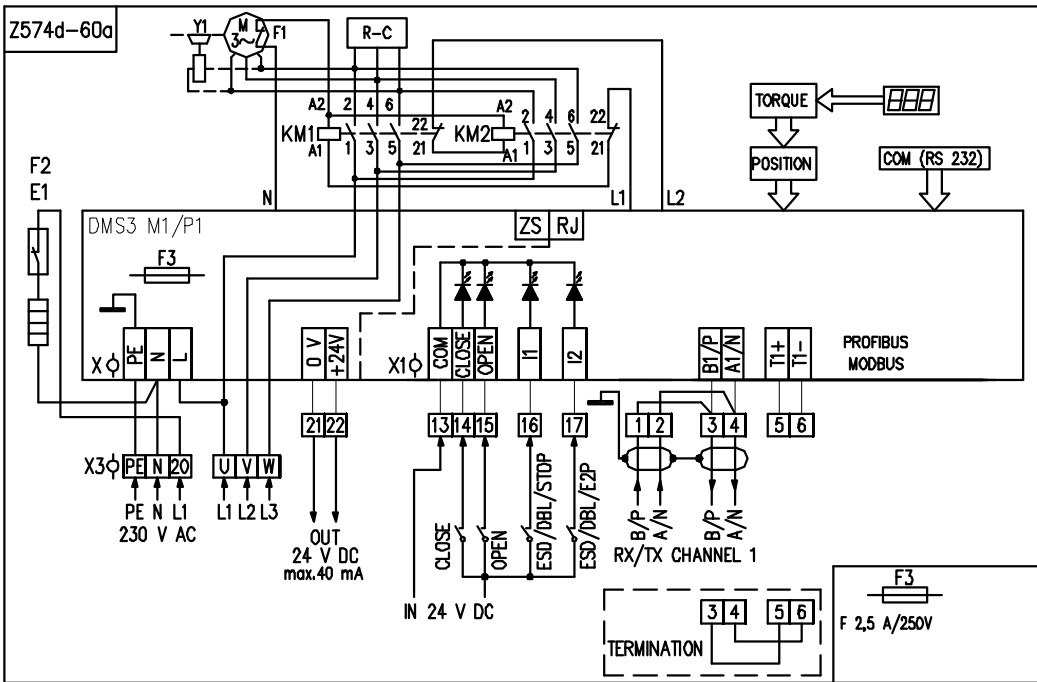

Wiring diagrams with of EA UMR 2PA electronic control with Modbus/Profibus protocol for three - phase supply – for ambient temperature -60°C do +40

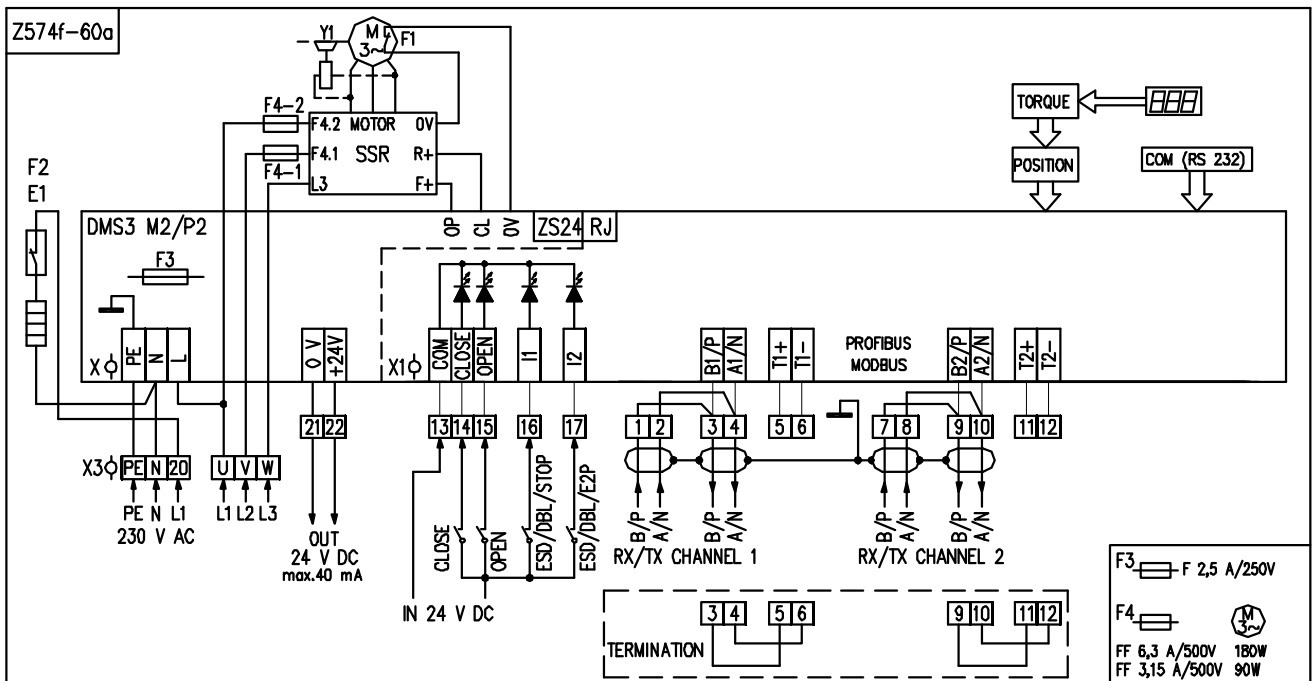
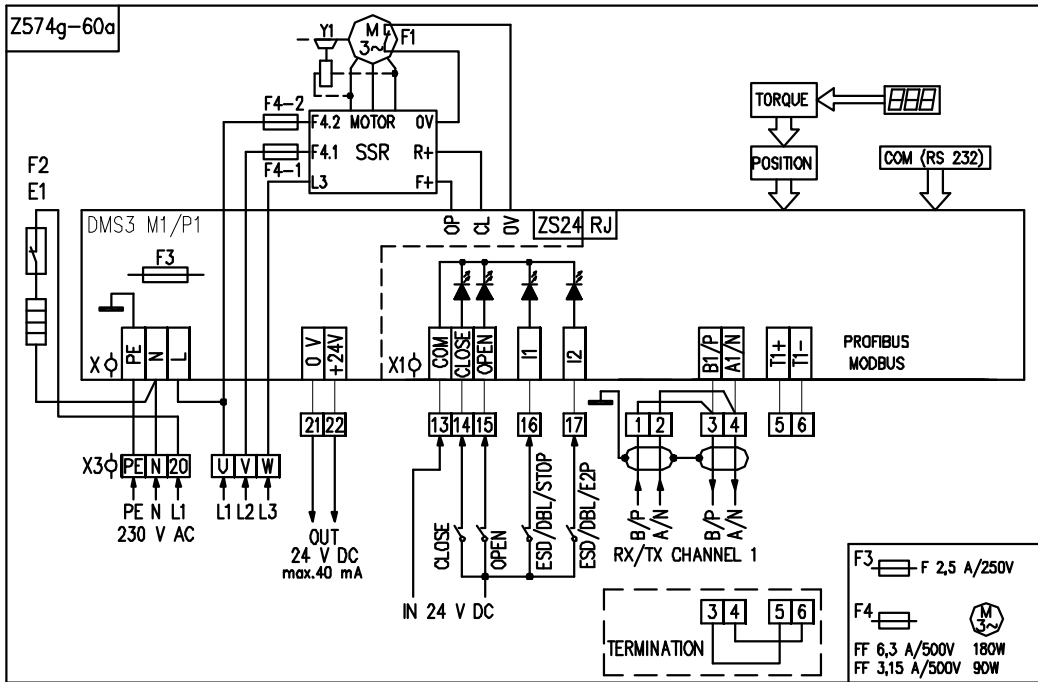

Wiring diagrams EA UMR 1PA– for 24V AC/DC, EA UMR 2PA - for 24V DC, electronic control with Modbus/Profibus – for ambient temperature -60°C do +40

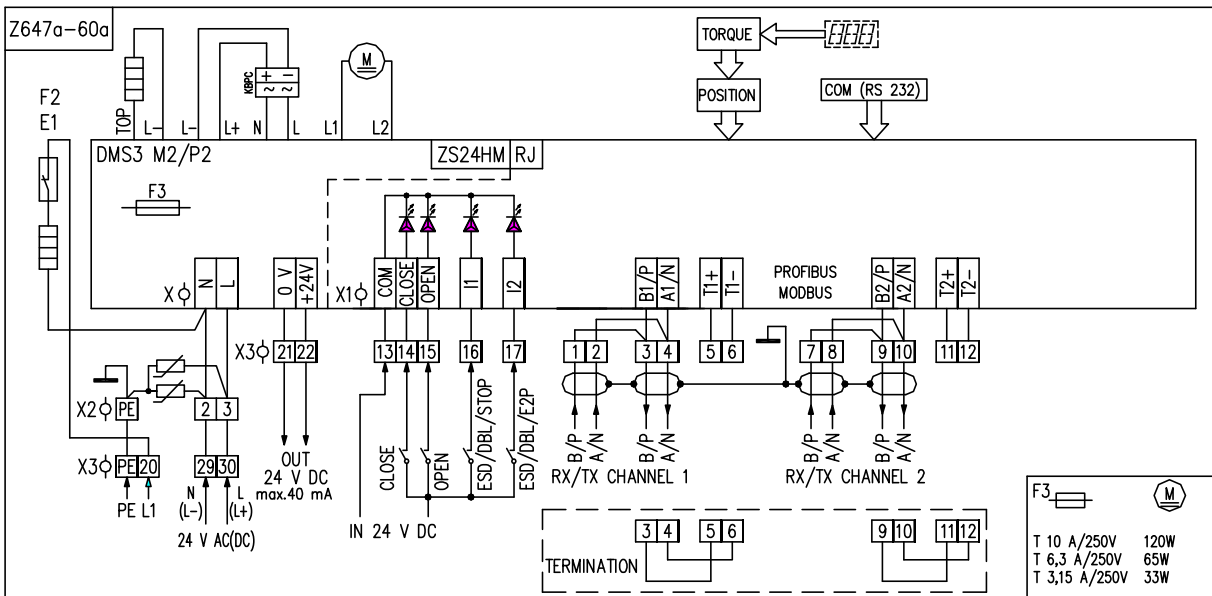
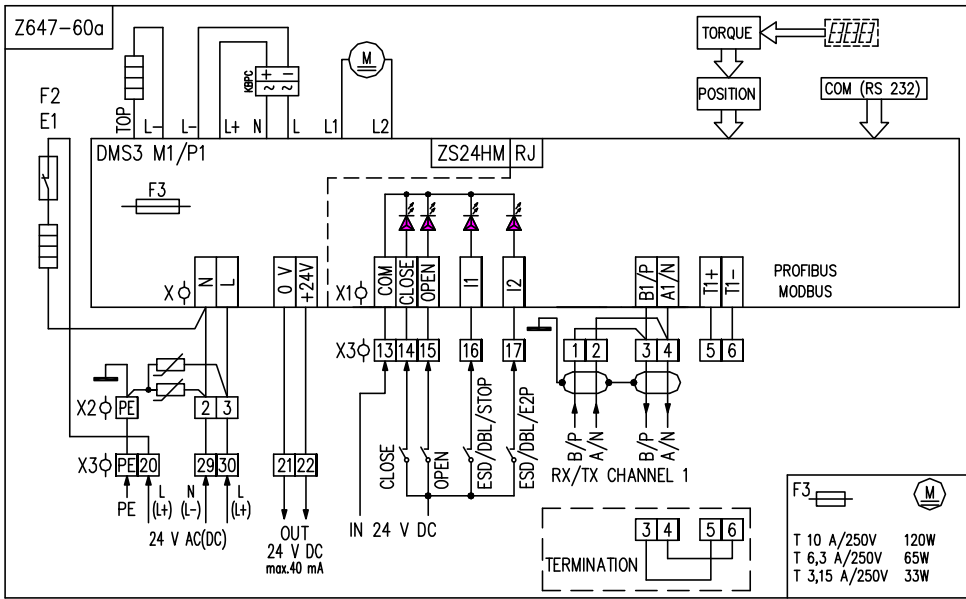

Wiring diagrams for additional relays and local control

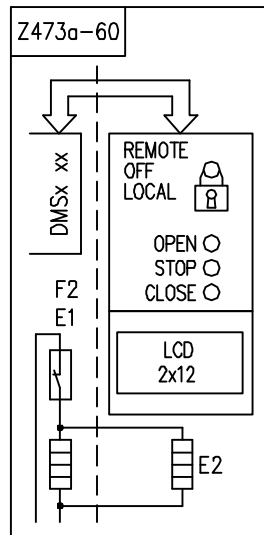
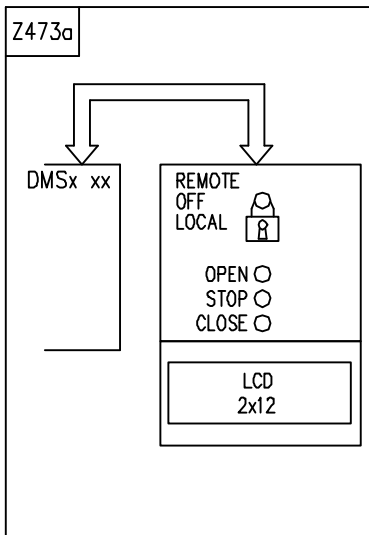
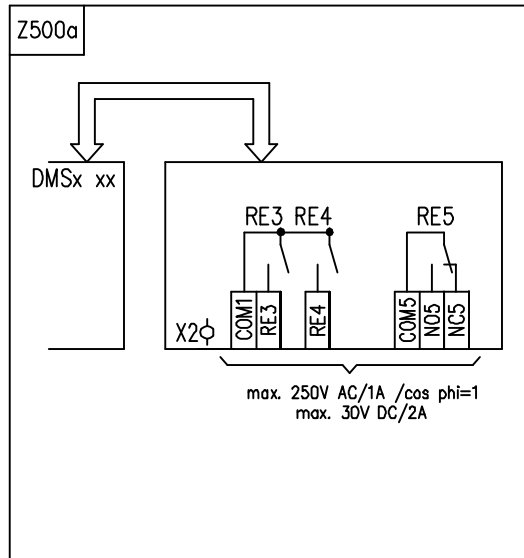
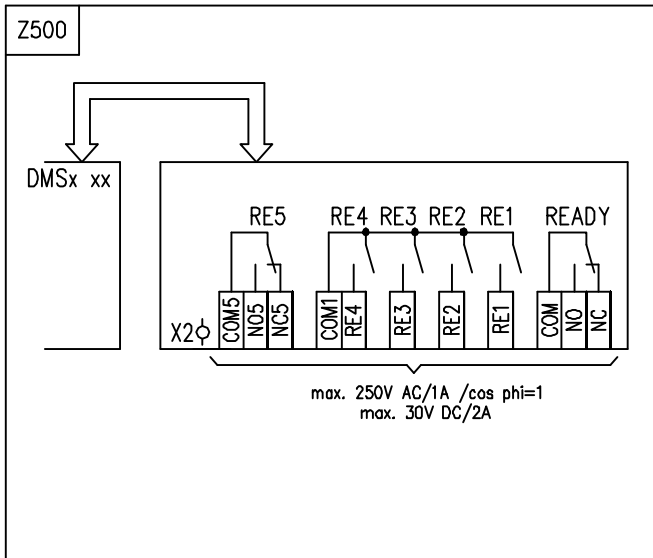

Wiring diagrams of customer versions

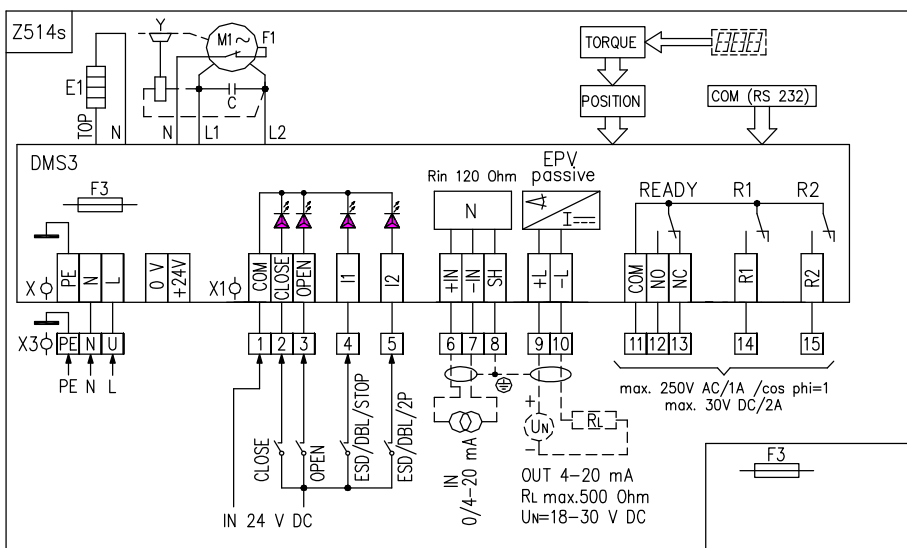
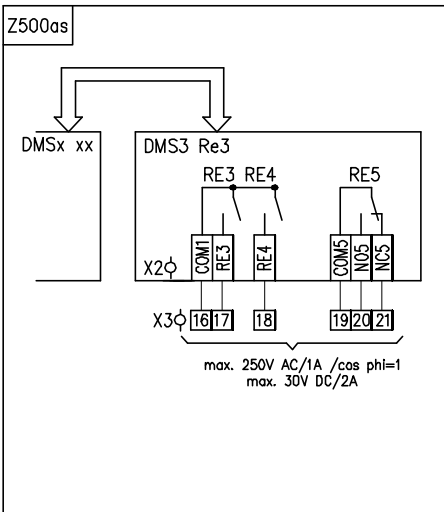
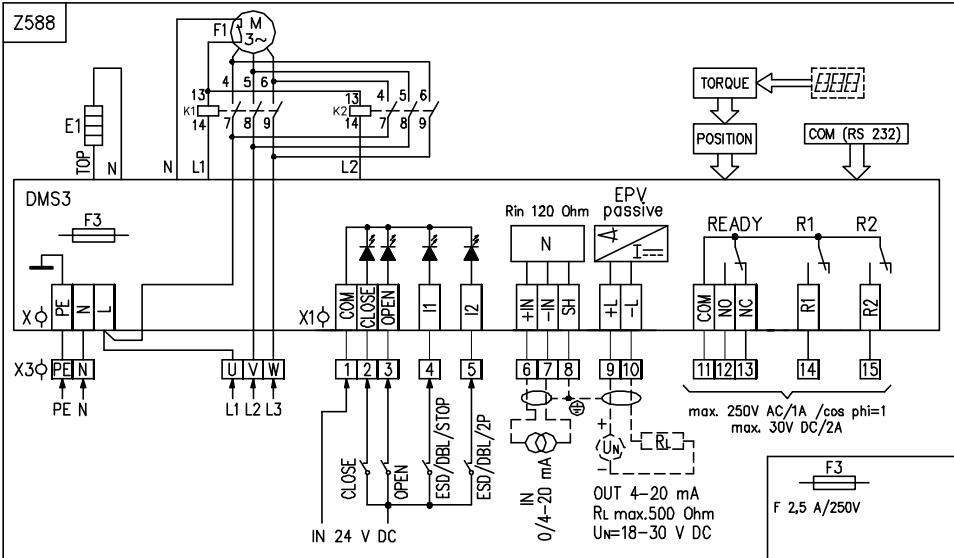

Legend:

Note: The legend to the wiring diagrams Zxxx (eg Z574c-60a) is identical with wiring diagrams with connection to connector ZKxxx (eg ZK574cc).

- Z473a.....wiring diagram of electric local control
 Z500.....wiring diagram module with 6 additional relays
 Z500a.....wiring diagram module with 3 additional relays
 Z500aswiring diagram module with 3 additional relays for terminal box with protection type "e"
 Z514.....wiring diagram of EA with 1-phase electric motor for the ON/OFF control or for analogue input 0/4/12 up to 20 mA, 4 up to 12 mA and output signal 4 - 20 mA
 Z514swiring diagram of EA with 1-phase electric motor for the ON/OFF control or for analogue input 0/4/12 up to 20 mA, 4 up to 12 mA and output signal 4 - 20 mA and with terminal box with protection type "e"
 Z515.....wiring diagram of EA with 1-phase electric motor for the ON/OFF control
 Z523.....wiring diagram of EA with 1-phase electric motor for the ON/OFF control or for analogue input 0/2 - 10 V and output signal 4 - 20 mA
 Z532.....wiring diagram of EA UMR 1PA with 3-phase electric motor for the ON/OFF control or for analogue input 0/4/12 to 20 mA, 4 to 12 mA and output signal 4 - 20 mA
 Z536.....wiring diagram of EA UMR 1PA with 3-phase electric motor for the ON/OFF control or for analogue input 0/2 - 10 V and output signal 4 - 20 mA
 Z537.....wiring diagram of EA UMR 1PA with 3-phase electric motor for the ON/OFF control
 Z532b.....wiring diagram of EA UMR 2PA with 3-phase electric motor with contactors for the ON/OFF control or for analogue input 0/4/12 to 20 mA, 4 to 12 mA and output signal 4 - 20 mA
 Z536b.....wiring diagram of EA UMR 2PA with 3-phase electric motor with contactors for the ON/OFF control or for analogue input 0/2 - 10 V and output signal 4 - 20 mA
 Z537b.....wiring diagram of EA UMR 2PA with 3-phase electric motor with contactors for the ON/OFF control
 Z532fwiring diagram of EA UMR 2PA with - 3-phase electric motor - for the ON/OFF control or for analogue input 0/4 - 20 mA and output signal 4 - 20 mA. Contactless switching of electric motor.
 Contactless switching of electric motor.
 Z536f.....wiring diagram of EA with - for the ON/OFF control or for analogue input 0/2 - 10 V and output signal 4 - 20 mA. Contactless switching of electric motor.
 Z537f.....wiring diagram of EA with - for 3-phase electric motor the ON/OFF control (2P). Contactless switching of electric motor
 Z637.....wiring diagram of EA with direct voltage for the ON/OFF control or for analogue input 0/4/12 to 20 mA or 4 to 12 mA and output signal 4 - 20 mA – 24 V AC/DC
 Z637awiring diagram of EA with direct voltage for the ON/OFF control or for analogue input 0/2 - 10 V and output signal 4 - 20 mA
 Z637bwiring diagram of EA with direct voltage for the ON/OFF control
 Z647.....wiring diagram of EA with direct voltage with communication protocol MODBUS / PROFIBUS – 1 channel – 24 V AC/DC
 Z647a.....wiring diagram of EA with direct voltage with communication protocol MODBUS / PROFIBUS – redundand – 24 V AC/DC
 Z574.....wiring diagram of EA UMR XPA with 1-phase electric motor with communication protocol MODBUS / PROFIBUS – redundand
 Z574a.....wiring diagram of EA of EA UMR XPA with 3-phase electric motor with reverse contactors with communication protocol MODBUS / PROFIBUS - redundand.
 Z574b.....wiring diagram of EA with 3-phase electric motor with communication protocol MODBUS / PROFIBUS – redundand
 Z574c.....wiring diagram of EA with 1-phase electric motor with communication protocol MODBUS / PROFIBUS - 1 channel
 Z574d.....wiring diagram of EA with 3-phase electric motor with reverse contactors with communication protocol MODBUS / PROFIBUS - 1 channel
 Z574e.....wiring diagram of EA with 3-phase electric motor with communication protocol MODBUS / PROFIBUS - 1 channel
 Z574g.....wiring diagram of EA UMR 2PA with 3-phase electric motor with communication protocol MODBUS / PROFIBUS - 1 channel. Contactless switching of electric motor
 Z588.....wiring diagram of EA with output 3-phase electric motor for ON / OFF control or for analog input signal 0/4/12 to 20 mA or 4 to 12 mA and output signal 4 - 20 mA for ES UMR 1PA and with terminal box with protection type "e".

Ccapacitor

COM(RS232) ...possibility for connecting the control unit to and PC

EPV passive ...electronic position transmitter is passive with output current signal

E1.....space heater

F1.....motor's thermal protection
 F3.....fuse of voltage supply source
 KM1, KM2coil of contactor
 K1,K2coil of relay

M.....single phase electric motor
 Ncontroller
 POSITION.....position scanning
 R_{in}input resistance
 R_L.....load resistance
 U_N.....voltage for EPV
 READY.....READY relay (free-programmable)
 R1 to RE5additional relays
 TORQUE.....thrust scanning
 DMS3electronic module
 DMS3 M1/P1 ...electronic module with interface Modbus/Profibus 1 Channel version
 DMS3 M2/P2 ...electronic module with interface Modbus/Profibus Redundant version

X.....voltage supply source terminal board with screw terminals
 X1.....terminal board with screw terminals on the control unit
 X2.....screw terminal box on the additional relays board
 X3.....screw, resp. terminal boards with spring connection (for Modbus/Profibus version)

Terminals for DMS3:

PE, N, L - terminals (0,05-1,5 mm²) of supply (24 V AC resp. 110/120 V AC, resp. 220/230 V AC, 50/60 Hz (according to the specification – voltage and frequency are stated on nameplate of EA)
 2, 3, 4 – terminals (0,08-2,5 mm²) of supply 3-phase motor 3x400 resp. 3x380 V AC resp. 3x415 V AC
 5,6 - terminals (0,08-2,5 mm²) wired motor/s thermal protection
 OP, CL - terminals (0,08 - 2,5 mm²) of the outputs of the direction rotations of the electric actuators (220/230 V AC)
 0 V, +24 V – terminals (0,05 - 1 mm²) of output voltage 24 V DC (40 mA)
 COM, CLOSE OPEN, I1, I2 – terminals (0,05 - 1 mm²) of control inputs 24 V /DC
 +IN, -IN, SH – terminals (0,05 - 1 mm²) of analogue input signal 0/4/12 up to 20 mA, resp.4 up to 12 mA
 +L, -L, SH – terminals (0,05 - 1 mm²) of output current signal (passive) 4-20 mA
 COM, NO, NC – terminals (0,05 - 1,5 mm²) relay READY
 COM, NO – terminals (0,05 – 1,5 mm²) relay R1,R2
 COM1, RE3, RE4 – terminals (0,05 - 1,5 mm²) relay RE3, RE4
 COM5, NO5, NC5 – terminals (0,05 – 1,5 mm²) relay RE5 (on the module of the additional relays)

Terminals for DMS3 24 V AC/DC:

2, 3 – terminals (0,08 - 2,5 mm²) of supply 24 V AC/DC
 0 V, +24 V – terminals (max. 1 mm²) of output voltage 24 V DC (40 mA)
 COM, CLOSE OPEN, I1, I2 – terminals (0,05 - 1 mm²) of control inputs 24 V DC
 +IN, -IN, SH – terminals (0,05 - 1 mm²) of analogue input signal 0/4/12 až 20 mA, resp.4 až 12 mA
 +L, -L, SH – terminals (0,05 - 1 mm²) of output current signal (passive) 4-20 mA
 COM, NO, NC, R1, R2 – terminals (0,05 - 1,5 mm²) READY relay, R1 and R2 relay on control unit
 COM5, NO5, NC5 – terminals (0,05 – 1,5 mm²) relay R1, R2 (on module of the additional relays)
 COM1, RE4, RE3, RE2, RE1 - terminals (0,05 – 1,5 mm²) of relay RE3, RE4 (on module of the additional relays)
 COM, NO, NC – terminals (0,05 – 1,5 mm²) relay RE5 (on module of the additional relays)

Terminals for DMS3 Modbus/Profibus:

- screwless terminals are in separately terminal box. cross-section of connection wire 0,08 - 2,5 mm²
 PE,N, U - terminals of supply voltage 230 V AC
 PE,N,U,V,W - terminals of supply voltage 3x400 V AC
 1,2,3,4,5,6 - terminals Single channel interface Modbus/Profibus
 7,8, 9,10, 11,12 – terminals Duo channel interface Modbus/Profibus
 21,22 – terminals of output voltage 24 V DC (40 mA)
 13,14,15,16,17 – terminals of control inputs 24 V DC

Note 1: On terminal N, L terminal power supply (X) feed supply voltage 230 V AC, or 120V AC by you - specified type of construction EA. For a version of EA with the supply voltage 3x400 or 3x380V, terminals N, L on terminal board of power supply (X) are fed by power supply 220 respectively 230 V AC.

Note 2: Three-phase electric motor in the electric actuators UMR 1PA do not have thermal protection of the electromotor F1 wired to terminals 5 and 6 (thermal protection of the electric motor is inbuilt).

Note 3: Program possibilities for **R1, R2, RE1, RE2, RE3, RE4, RE5** relays: DISABLED, open position, close position, torque-open, torque – close, torque open or torque close, torque open or position open, torque close or position close, open, close, movement, movement flasher, to position, from position, warning, remote control, local control, control shut off, relay READY.

Program possibilities for **READY** relay: errors, errors or warnings, errors or no remote, errors or warnings or no remote.

Program possibilities for output signal (from **EPV** passive): 4 to 20 mA, 20 to 4 mA.

Control programme options (regulating)(**this does not apply to EA's equipped with a Modbus/Profibus protocol**): 2P, 3P, 3P/2P switched over to I2

Program possibilities **for input control signal (N)**: 4 to 20 mA (2 to 10 V), 20 to 4 mA (10 to 2 V), 0 to 20 mA (0 to 10 V), 20 to 0 mA (10 to 0 V).

Program possibilities for setting Modbus communication protocol:

address – 1 to 247

baudrate [bit/s] – 1200, 2400, 4800, 9600, 19200, 38400, 57600, 115200

parity – even, odd, none

redundancy –off, cable, component, repeater

connect time [s] – 0,1 to 25,5s

Program possibilities - for Profibus protocol

Address 1 – 1 ... 126

Address 2 – 1126

Redundancy: - Off, Simple

Program possibilities **for inputs I1**: DISABLED, ESD, DBL (local releasing, remote releasing), STOP.

Program possibilities **for inputs I2**: DISABLED, ESD, DBL (local releasing, remote releasing), STOP

2P, resp. E2P (when controller is switch on)(for control programme option 3P/2P I2, resp. for active communication through Modbus/Profibus protocol) allows control using the binary 24V DC inputs with I2 input activated.

Program possibilities of FAILURE REACTION ESD: OPEN, CLOSE, STOP, SAFE POSITION.

The identical functions cannot be set on I1 &I2 inputs in addition to the disabled state (e.g., if the SAFE function is set on I1 input, it is not possible to select the ESD function on I2 input at the same time.

Relay **READY** on the control unit is doubled with relay **READY** on the power supply board.

Relay **R1** and relay **R2** on the control unit is doubled with relay **RE1** and relay **RE2** on the power supply board.

7.2 Dimensional drawings

Multi-turn actuators Unimact UMR XPA

P-2135

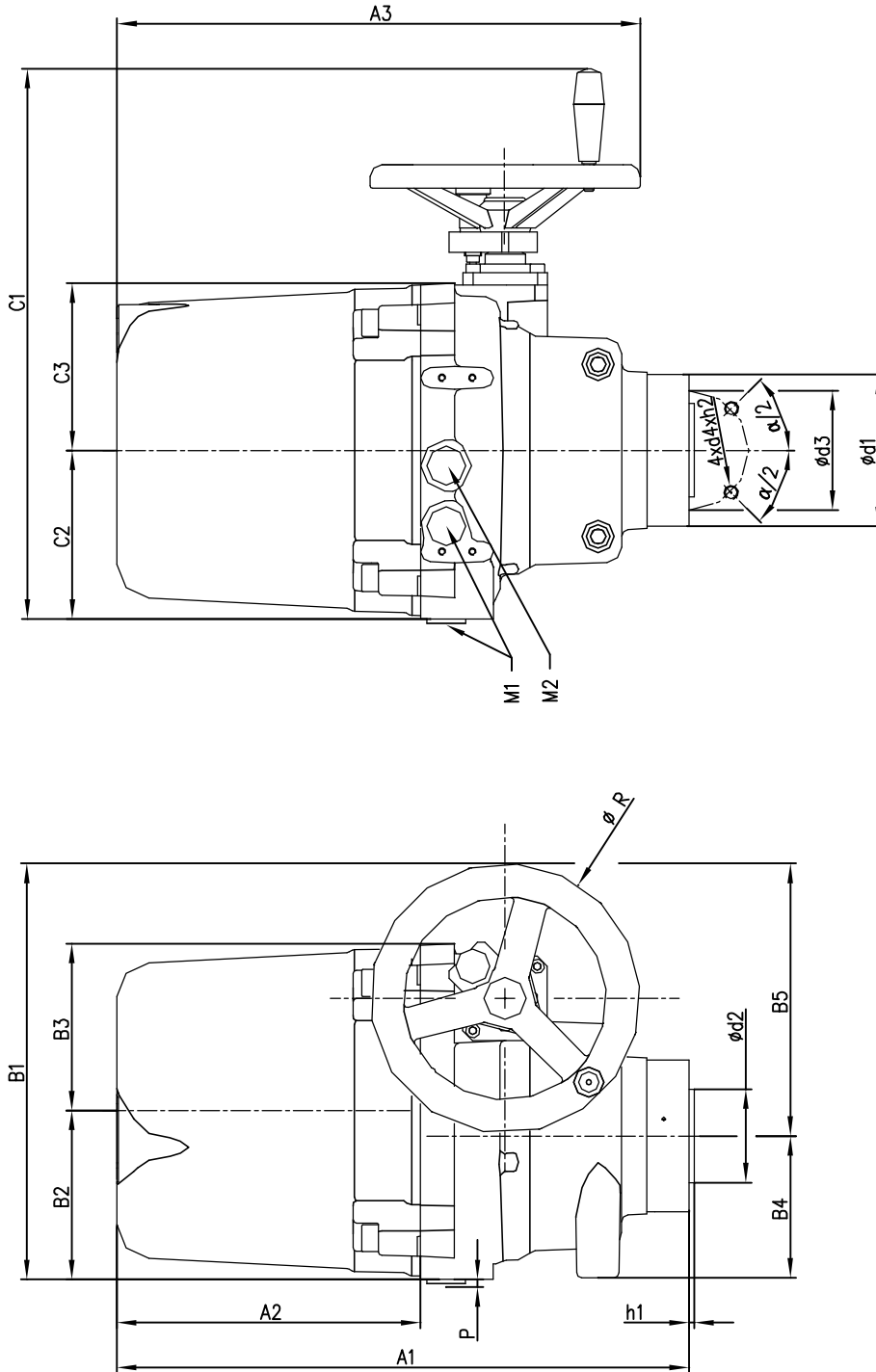

Главные размеры / Основные размеры / Main dimensions

	A1	A2	A3	B1	B2	B3	B4	B5	C1	C2	C3	M1	M2	P	R	α/2	d1	d2	d3	d4	h1	h2
UM 1	F05	180	310	247	100	99	84	162	326	100	98	M20x1.5	M20x1.5	4.5	160	45°	90	-	50	M6	-	20
	F07	339																	70	M8		16
UM 2	F07/F10	408	220	380	295	115	91	195	376	115	113	M20x1.5	M20x1.5	4.5	200	45°	120	-	70/102	M8/M10	-	16/20

P-2136

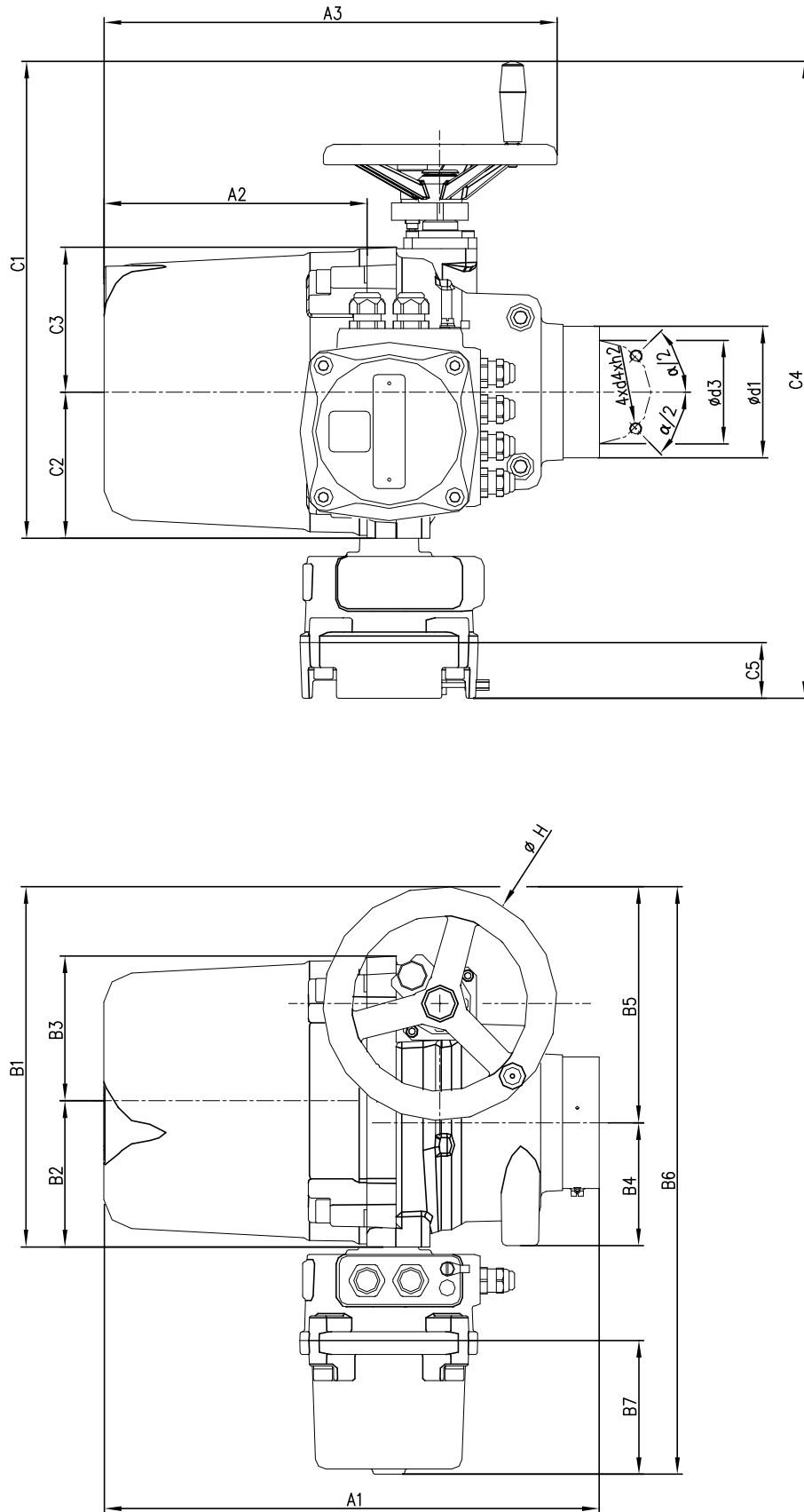

Главные размеры / Основные размеры / Main dimensions

	A1	A2	A3	B1	B2	B3	B4	B5	B6	B7	C1	C2	C3	C4	C5	alpha/2	d1	d3	d4	h2
UM 1	F05	180	310	247	100	99	84	162	402	92	326	100	98	436	38	45°	90	50	M6	20
	F07	339															70		M8	
UM 2	F07/F10	408	220	380	295	112	91	195	450	92	376	115	113	485	38	45°	120	70/102	M8/M10	16/20

ISO 5210, shape A

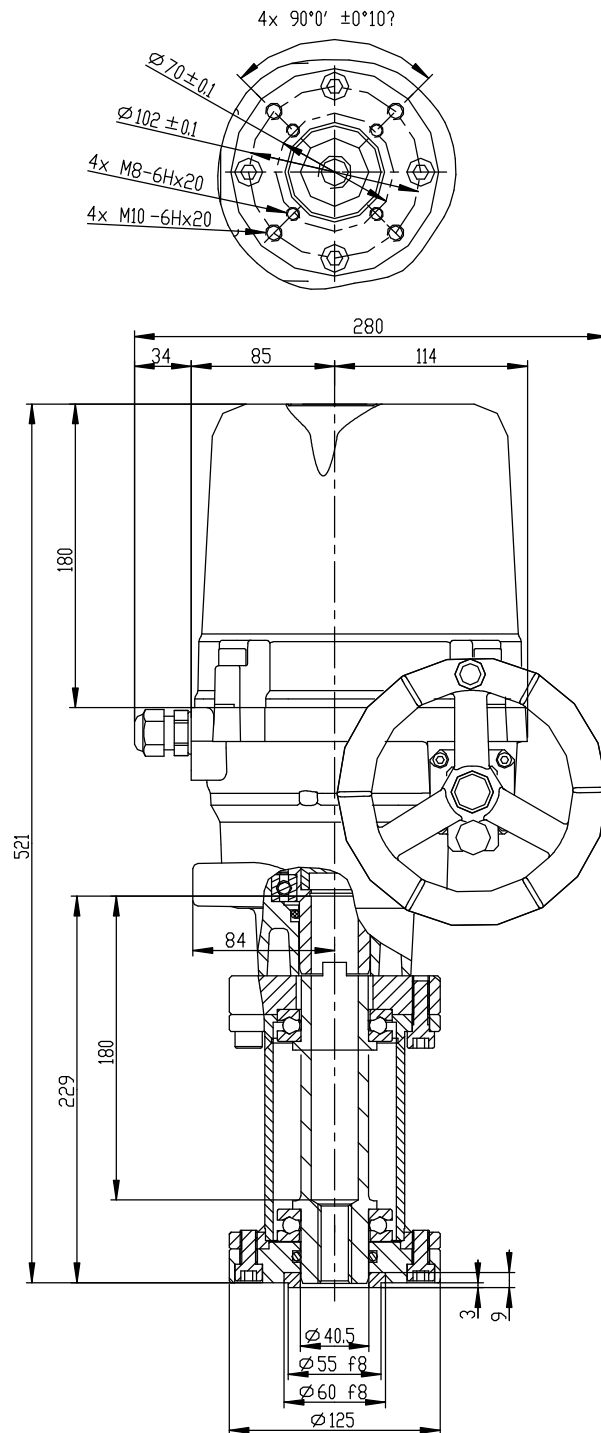

P-1500

7.3 Guarantee service check report

Service center:	
Date of repair:	Guarantee repair no.:
User of actuator:	Claim applied by:
Actuator type number:	Actuator production number:
Product claim fault:	Detected product fault:
Used spare parts:	
Remarks:	
Issued on a day:	Signature:

7.4 Post guarantee service check report

Service center:	
Date of repair:	
User of actuator:	Actuator operating place :
Actuator type number:	Actuator production number:
Detected product fault:	
Used spare parts:	
Remarks:	
Issued on a day:	Signature:

7.5 Commercial representation

Slovak Republic:

Regada, s.r.o.,
Strojnícka 7,
080 01 Prešov
Tel.: +421 (0)51 7480 460,
Fax: +421 (0)51 7732 096,
E-mail: regada@regada.sk