



INSTALLATION, SERVICE AND MAINTENANCE INSTRUCTIONS



***Electric linear actuators Rematic
with the DMS 3 electronic control STR 0.1PA***

TEST CERTIFICATE

ELECTRIC LINEAR THRUST ACTUATOR STR 0.1PA	
Type number 438.....	Power supply V Hz
Serial number	Max. load thrust N
Production year	Switch-off thrust N
Wiring diagram	Operating speed mm/min
.....	Set stroke mm
.....	Control
.....	Input operation signal
Warranty period months	Output signal
Serial number of electric motor	
Serial number of control unit	
Tests made by	Packed by
Date	Signature and stamp

COMPLETENESS CERTIFICATE

Used valve	
Assembled by: Firm	
Name.....	
Warranty period months	
Date	Signature and stamp.....

INSTALLATION CERTIFICATE

Location	
Installed by: Firm	
Name	
Warranty period..... months	
Date	Signature and stamp.....

Please read these instructions carefully before mounting and operating the actuator!

Preventive and safety-measures applied on the actuator can not offer required safety level till the actuator and its safety systems are not applied by required and described way and if installation and maintenance is not applied according to applicable instructions and rules!

Contents

1. General data	2
1.1 Purpose and applications	2
1.2 Safety instructions	2
1.3 Instructions for stuff training.....	2
1.4 Warning for safety use.....	3
1.5 Data specified on electric actuator.....	3
1.6 Guaranty Conditions	4
1.7 Under-guarantee and after-guarantee service.....	4
1.8 Operation conditions.....	4
1.9 Description.....	6
1.10 Basic specifications	8
1.11 Conservation, packing, transport, storing and unpacking	16
1.12 Assessment of the product and packaging and removal of contamination	16
2. Installation and dismantling of actuator	17
2.1 Installation	17
Abide by safety measures!	17
2.2 Dismantling.....	20
3. Adjusting of actuator	21
3.1 EA control set-up options (regulating)	25
3.2 Procedure for setting individual parameters and the register of errors and warnings ...	27
3.3 Putting an EA into operation when the EA is set up and connected with the armature already in the production plant (starting the calibration).....	31
3.4 Putting an EA into operation when the stroke and parameter setting done by the producer suit to your needs.....	31
3.5 Putting an EA into operation when it is necessary to do a change to the stroke (setting new end positions), and the other parameter setting done by the producer suits to your needs	31
3.6 Setting other parameters	32
3.7 Error messages from the control unit.....	32
4. Service and Maintenance.....	33
4.1 Service.....	33
4.2 Maintenance - extent and periodicity	34
4.3 Troubleshooting.....	35
5. Accessories and spare parts	38
5.1 Accessories	38
6. Enclosures	39
6.1 Wiring diagrams.....	39
6.2 Dimensional drawings.....	47
6.3 Guarantee service check report.....	56
6.4 Post guarantee service check report	57
6.5 Commercial representation.....	58

The Installation, Service and Maintenance Instructions are drawn up according to requirements of EC Executive Nr. 2006/42/EC "Uniform requirements for machines and devices from the point of view of safety and health care", to save life and health of users and to avoid material damages and exposure environment to danger.

1. General data

1.1 Purpose and applications

Electric linear actuators **Rematic** (hereinafter referred as EA only) with the DMS 3 electronic control of the **STR 0.1PA** type are set up by the program to be controlled on the 24 V DC voltage level; are set up by the program to be controlled by analogue input signal, potentially controlled through a interface with **Modbus/Profibus** communication protocol.

Electric linear actuators **STR 0.1PA** types are high-powered electric-mechanical products designed for direct installations onto controlled devices (regulating bodies - valves, etc.). EA of STR 0.1PA types are provided for remote control of closing bodies, or for automotive control of regulating bodies in both directions of their movement. They can be equipped with means of measuring and control of technological processes where an unified analogue direct current resp. voltage signal is an information bearer on their input and/or output (not valid for EA's with Modbus/Profibus protocol). They can be used in heating, energy, gas, air-conditioning and other technological systems, which they are suitable for, regarding their features. They are connected with the controlled devices with flanges according to ISO 5210 or using pillars and flanges.



1. *It is forbidden to use EA as a lifting mechanism!*

1.2 Safety instructions

Product characteristics from risk point of view



EA of STR 0.1PA types are reserved technical devices with higher rate of danger, with possibility of installation in areas specially danger regarding casualties caused by electric current.

Electric actuators are according to directive LVD 2014/35/EU and standard EN 61010-1+A1 in terms of valid certificate, assigned for installation category II (overvoltage category), pollution degree 2.

Product influence to environment

Electromagnetic compatibility (EMC): the product complies with the requirements of the Directive 2014/30/EU of the European Parliament and of the Council on the approximation of the laws the Member States relating to the electromagnetic compatibility and with the requirements of standards as well EN IEC 61000-6-4, EN IEC 61000-6-2, EN IEC 61000-3-2+A1 and EN 61000-3-3+A1, in the edition in terms of valid certificate.

Vibrations caused by the product: product influence is negligible.

Noise produced by the product: the maximum allowable noise level (A) of the product measured in a place of operation is 80 dB (A).

1.3 Instructions for staff training

Requirements for professional qualification of people performing installation, service and maintenance



The electrical connection of the actuator can only be carried out by a person in accordance with legislative requirements of the given country, depending on the required areas of location/use. Service can be performed only by workers professionally qualified and trained by the producer or contracted service centre.

1.4 Warning for safety use



1. Products are assigned for operation in environment consist of gas, steam and vapours, with temperature range: -25°C to $+55^{\circ}\text{C}$, with pressure range from 0.8 to 1.1 bar.
2. If the actuator is placed on device which regulate medium with higher temperature than $+55^{\circ}\text{C}$, protect the actuator by additional construction in order to maintain ambient temperature max. $+55^{\circ}\text{C}$ and also to stop temperature transmitting through junction component!
3. Cable glands blinds are assigned only for transport and storage period, i.e. for period till the actuator is builded into operation, than blinds must be replace by connecting cable.
4. In case of not using one of the cable gland, it has to be replaced with a suitable blinding plug.

Temperature at the point where the cables enter the actuator can reach max. 90°C . When choosing the connection cables for the actuator, it is therefore necessary to consider this temperature as well

Product protection:

There must be included suitable protective device into the power supply (circuit breaker or fuse) which serves at the same time as main switch.

EA STR 0.1PA is provided with its own short-circuit protection of 1-phase motor power supply circuits and space heater. There must be included suitable protective device into the power supply of 3-phase motor (circuit breaker or fuse) which serves as main switch as well. For protection, we recommend to use a fuse type "T" or a contactor type "C".

Type of equipment from a connection point of view: The equipment is designed for permanent connection.

1.5 Data specified on electric actuator

Nameplate:

REGADA	CE		IP		V	A	
⊕	TYP		Nº		⊕		
	kN	↔	kN		mm.min ⁻¹		mm

Warning plate:



Nameplate contains the basic data concerning identification, performance and electricity: indication of producer, type, serial number, load thrust and switching-off thrust, operating speed, protection code, operating stroke, supply voltage and current.

Graphic symbols on electric actuator

The graphic symbols used on electric actuator substitute the text messages. Some of them are in accordance with EN ISO 7010, ISO 7000 and IEC 60417 within valid edition.



Dangerous voltage

(EN ISO 7010-W012)



Stroke of the electric linear actuator



Switching-off thrust



Manual control

(0096 ISO 7000)



Protection terminal

(5019 IEC 60417)

1.6 Guaranty Conditions

The supplier is responsible for completeness of the delivery and guarantees proprieties of the product, stated by technical conditions (TC), or proprieties agreed upon on purchase contract.

The supplier is not responsible for product deteriorated properties caused by the customer during storing, non professional assembly, or non professional operation.

1.7 Under-guarantee and after-guarantee service

Under-guarantee service is performed by the service department of the production plant, or by a contracted service centre according to a written claim.

In case of occurring of any fault please let us know it and state:

- basic data from nameplate: type code and serial number
- type of fault - description of claimed fault (actuator employment, ambient parameters (temperature, humidity...), duty cycle including frequency of switching, type of switching-off (position or thrust), set switching-off thrust, contact to the company implementing the installation and electric connection
- it is recommended to place also Installation certificate.

It is recommended to have **after-guarantee service** performed by the service department of the production plant, or by a contracted service centre. Serviceman makes the record about service mission after warranty actions and sends it to the production company.

1.7.1 Lifetime of actuators

The lifetime of an electric actuator (EA) is at least 6 years.

EA used for closing mode (closing valves) comply with the requirements for at least **15,000 working cycles** (cycle C – O – C: for linear EA).

EA used for regulating/modulating operation (control valves) comply with the below stated numbers of **operating hours** at the total number of 1 million start-ups:

Switching frequency				
max. 1,200 [h ⁻¹]	1,000 [h ⁻¹]	500 [h ⁻¹]	250 [h ⁻¹]	125 [h ⁻¹]
Minimal lifetime expectancy – number of operating hours				
850	1,000	2,000	4,000	8,000

Time of **net operation** is min. 200 hours, max. 2,000 hours.

Lifetime at operating hours depends on loading and switching frequency.

Note : High switching frequency does not ensure better regulation. Setting of regulation parameters should be therefore made with the inevitably necessary switching frequency needed for the process in question.

1.8 Operation conditions

1.8.1 Product location and operation position

- The assembly and operation of electric actuators in standard make can be on covered places of industrial objects without the regulation of temperature, humidity and with protection against direct exposure of climate influence (e.g. direct sun shine).
- Electric actuators must be placed with access to the manual handle (5), Fig.4 and Fig.6, to the cover of control box, to control box, to cable glands, to local electric control.
- Installation and operation of actuators is possible in either position. Common position is the one with vertical position of exit part axis and control box above. Avoid to arrange the electric actuator under the armature if possible.

Warning:



Actuator installed on the open place must be protected against a direct climate effects by shelter, mainly from sunshine. In applications placed in an ambient of a relative moisture above 80%, in external ambient under shed, it is necessary to change the preset thermostat temperature +25°C to +70°C by a PC and program to prevent switching off the heating

resistor.

1.8.2 Operation Environment

According to valid standard IEC 60 721-2-1, there are delivered these versions of electric actuators:

- 1) Version „standard“ for type climate temperate
- 2) Version „tropical wet“ for type climate tropical wet
- 3) Version „tropical dry and dry“ for type climate tropical dry and dry
- 4) Version „marine“ for type climate marine

In accordance with IEC 60 364-1, IEC 60 364-5-51 and IEC 60 364-5-55 within valid edition the EA have to resist external effects and operate reliably:

In the conditions of the following types of environment:

- warm mild to very hot dry with temperature in range -25°C to $+55^{\circ}\text{C}$ **AA 7***
- in industrial environment:** at temperatures stated above
- with relative humidity 10 to 100 %, including the condensation of up to 0,029 kg water content per 1 kg of dry air at 27°C , at above stated temperature**AB 7***
- with height above sea level 2 000 m, with barometric pressure range 86 to 108 kPa**AC 1***
- with effect of salient water from all directions - (product in enclosure IP x5)**AD 5***
- a possibility of partial or complete immersion - (products with protection enclosure IP x7)**AD 7***
- with submersion – (product with enclosure IPx8)**AD 8***
- with strong dustiness – with a possibility of influences of inflammable, non-conducted and non-explosive dust; the middle layer of dust; the dust drop more than 350 but not more than 1000 mg/m^2 per day (products with protection enclosure of IP 6x)**AE 6***
- with atmospheric appearance of corrosive and spoiling materials (with high degree of corrosive aggressiveness of the atmosphere; the presence of the corrosive spoiling materials is significant**AF 2***
- with permanent exposure of big amount of corroding or contaminated chemicals and salt fog in execution for sea environment , for sewage water disposal plant and some chemical plant....**AF 4***
- with a possibility of influences of mechanical stress:
 - of mean sinusoid vibrations with frequency in range 10 to 150 Hz, with amplitude of shift 0,075 mm for $f < f_p$ and with amplitude of acceleration $9,8 \text{ m}/\text{s}^2$ for $f > f_p$; (contact frequency f_p is 57 to 62 Hz).....**AH 2***
 - of mean sinusoid vibrations with frequency in range 10 to 150 Hz, with amplitude of shift 0,15 mm for $f < f_p$ and with amplitude of acceleration $19,6 \text{ m}/\text{s}^2$ for $f > f_p$; (contact frequency f_p is 57 to 62 Hz) – applies for 4 pillars version**AH 2***
 - medium impacts, shakings and vibrations**AG 2***
- growing of plants and moulds**AK 2***
- with strong danger of presence of animals (insects, birds, small animals)**AL 2***
- with harmful effects of radiation:
 - of escaping stray current **AM 2-2***
with intensity of magnetic field (direct and alternating of power supply frequency) to $400 \text{ A}\cdot\text{m}^{-1}$
 - mean sunshine with intensity > 500 and $\leq 700 \text{ W}/\text{m}^2$ **AN 2***
- mean seismic effects with acceleration $> 300 \text{ Gal}$ $\leq 600 \text{ Gal}$ **AP 3***
- with indirect danger of storm activity**AQ 2***
- with fast moving of air and strong winds**AR 3 , AS 3***
- with frequent contact of the staff with earth potential (persons often touch conductive parts or they stand on the conductive basement)**BC 3***
- without occurrence of dangerous media in the object**BE 1***

* Marking in accordance with IEC 60364-1, IEC 60 364-5-51 and IEC 60 364-5-55 within valid edition

1.8.3 Power Supply and Operation Modes

Power supply:

Electric motor..... 110/120 V AC, 220/230/240 V AC, 3x400 /3x380 $\pm 10\%$ V AC resp.24 V AC $\pm 10\%$
 Controlbinary inputs 24 V DC $\pm 10\%$
input control signal 0/4/12 up to 20 mA, 4 up to 12 mA resp. 20 up to 0/4/12 mA, 12 up to 4 mA,
 or 0/2 up to 10 V, resp. 10 up to 0/2 V

Electronic positional transmitter (EPV) without power supply (passive)	18 up to 30 V DC $\pm 10\%$
communication protocol (by version)	Modbus (either single Channel or duo Channel)
.....	Profibus (either single Channel or duo Channel)
Frequency of power supply	50/60* Hz $\pm 2\%$

* At frequency of 60 Hz operating speed is increased by 1.2 times.

Duty cycle - according to EN 60034-1,8 (IEC 60034-1, 8):

EA STR 0.1PA are designed - **for remote control:**

- short-time operation S2-10 min
- intermitted operation S4-25%, 6 up to 90 cycles per hour

- **for automatic regulation:**

- intermitted operation S4-25%, 90 up to 1200 cycles per hour.

Note: The operation modes consist of the loading type, load factor and connection/switching frequency.

Warning: Non-compliance with operating mode may result in inactivation of the EA as a result of failure of the integrated thermal fuse (protection) of the electric motor.

1.9 Description

The **STR 0.1PA** electric actuator is controlled according to version

- by 24 V DC voltage fed to the electric actuator's terminals according to the wiring diagram, resp.
- input control signal by 0/4/12 to 20 mA, 4 to 12 mA (0/2 to 10 V) and provides for moving the output part of the EA automatically to a position corresponding to the value of the input signal) and other functions as well
- through Modbus reso. Profibus communication interface.

The electric actuator consists of these main parts (Fig. 1):

The electric actuator is driven by an **electric motor (1)** supplied and controlled from the **source board (3)** and **control unit (2)** of the DMS 3 electronics.

Position of output element of EA is scanned by **contactless absolute sensor**. Thrust is scanned with thrust switches S1 and S2.

Depending on the version, the DMS3 electronic circuit board may include an **electronic position transmitter (EPV)** without power supply (passive) with output signal 4 through 20 mA.

Space heater (5) is placed at the control board.

In case of power cut or damage of switches the actuator can be controlled by **manual handle** according to instructions stated in chapter 4. Service and Maintenance.

Basic modules of DMS3 electronic control system for STR 0.1PA:

Control unit (2) – main part of system DMS3 – it contains microprocessor, 6 signal LED and 4 buttons for simple adjustment and control of EA, connectors for connection of thrust scanner and sourcing board and communication connector (connection to PC for adjustment and diagnostic), according to version 2 free programmable relays R1 and R2,, 1 relay READY and terminals for electric connection.

Sourcing board for single-phase version **(3)** – secures power supply of electronic and provides an output voltage of 24 V DC, 40 mA for the user, it contains user terminal board, switching circuits, connector for connection with control unit.

Position scanning unit (4) – secures contactless magnetic position scanning of output element.

Thrust unit (6) - ensures switching off of the EA when the set switching off thrust is reached.

Switching unit for 3-phase electric motors - reversing relay

LED display (7) – shows instant position of EA output member and reports and displays potential errors, which would occur when EA is operated. Signalling motion and failure of the EA is also indicated by LEDs diode. LED display is used only pro type of construction EA without local control.

Manual control - it consists of a manual handle on the top cover of the actuator

Terminal box (Fig. 2B) is as standard equipment for EA with communication protocol Modbus / Profibus.

Other accessories – as optional accessories:

- Module 3, or 6 additional relays (according to version) (8).
- local electric control module equipped with 2-line LCD display (fig. 7).

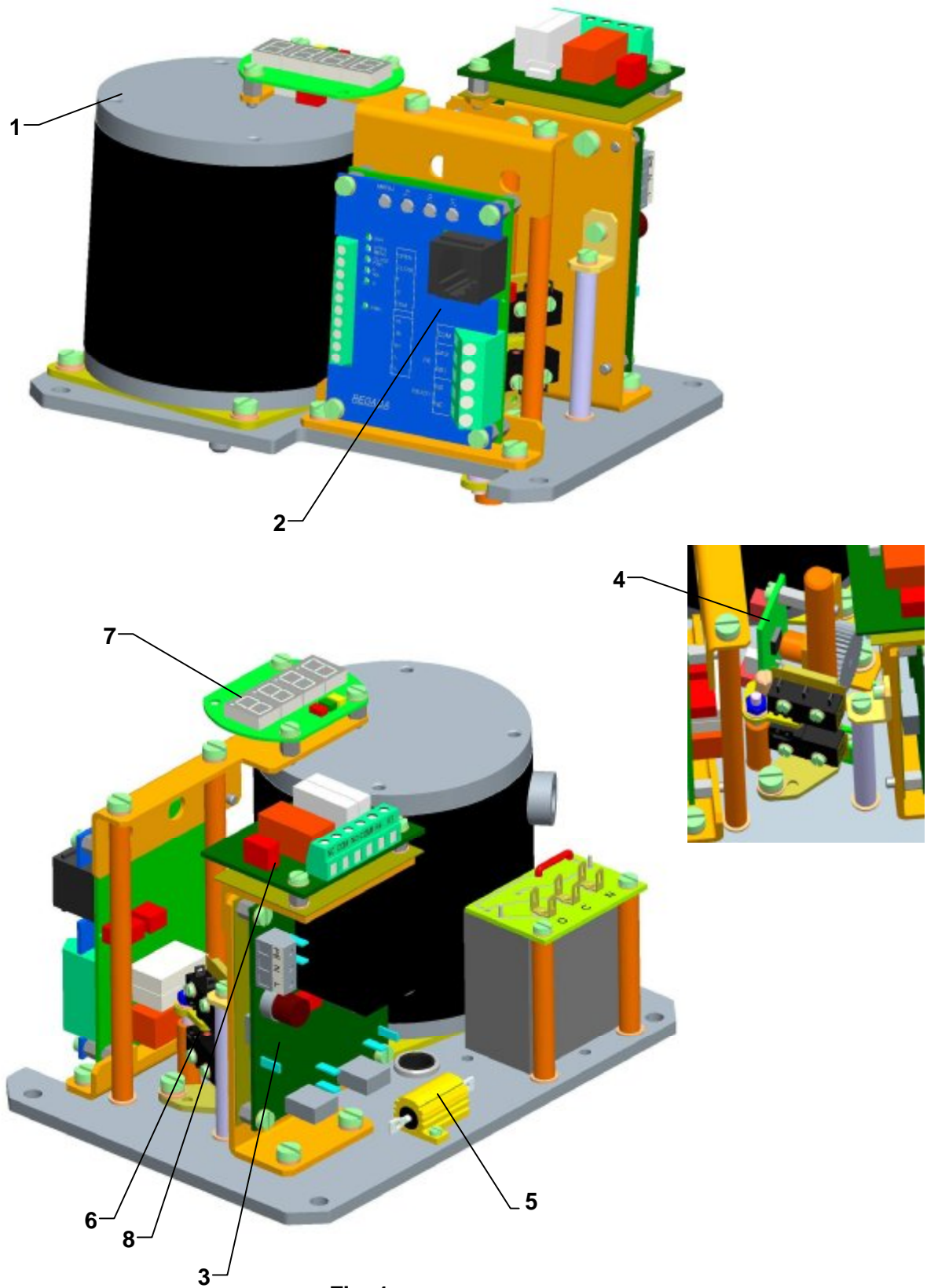

1.10 Basic specifications

Basic EA specifications:

Max. load thrust [N], operating speed [mm/min], operating stroke [mm], switching-off thrust [N], and electric motor parameters are given in Table 1.

Table 1: Basic EA Specifications

Type/type number	Operating speed ±10[%] ¹⁾		Operating stroke	Max. load thrust (regulation mode)	Max. load thrust (remote control)	Switching-off thrust ±10 [%]	Weight	Electric motor					
								Supply voltage nominal voltage/ frequency		Nominal			Capacitor capacity.
										power	revolutions	current for	
	mm/min			[N]	[N]	[N]	[kg]		[V/Hz]	[W]	[1/min]	[A]	[µF/V]
	50 Hz	60 Hz											
1	2	3	4	5	6	7	8	9	10	11	12	13	14
STR 0.1PA, type number 438	10	12	10 - 50	2600	3200	3600	5,5-8,5 - in accordance with version of mechanical connection	Single-phase	24/50-60 120/60 220/50 230/50 240/60	15/18 18 15 15 18	2750/3350 3350 2750 2750 3350	2,1 0,44 0,28 0,28 0,22	150/63 6/250 1,5 2,2/350 1,5 2,2/350 1,5/400
	16	19											
	25	30											
	32	38											
	40	48											
	63 ²⁾	75											
	10	12		3200	4000	4600							
	16	19											
	25	30											
	32	38											
	40	48											
	63 ²⁾	75											
	10	12	4000	5000	5800								
	16	19											
	25	30											
	32	38											
	40	48											
	63 ²⁾	75											
	10	12	5000	6300	7200								
	16	19											
25	30												
32	38												
40	48												
63 ²⁾	75												
10	12	10 - 50	2600	3200	3600	5,7-8,7 - in accordance with version of mechanical connection	Three-phase	3x400/3x380	15	2680	0,10	-	
16	19												
25	30												
32	38												
40	48												
63 ²⁾	75												
10	12		3200	4000	4600								
16	19												
25	30												
32	38												
40	48												
63 ²⁾	75												
10	12	4000	5000	5800									
16	19												
25	30												
32	38												
40	48												
63 ²⁾	75												
10	12	5000	6300	7200									
16	19												
25	30												
32	38												
40	48												
63 ²⁾	75												

- 1) Anomaly of operating speed: - 15% at temperature under - 10°C
- 2) For automotive regulation the operating speed 63mm/min is not recommended
- 3) The total current of EA is the sum of the electronics current (0.15 A) and the electric motor current according to the EA version

Other specifications:

Protection enclosure of EA:..... **IP 67, IP 68** EN 60 529 (IEC 60 529)

According to definition for EA, enclosure IP68 fulfills following requirements:

- water column max. 10m
- time of continuous submersion in water max. 96 hours.

Mechanical ruggedness:

sinusoid vibrations see Chapter 1.7.2
 resistance by drops..... 300 drops with acceleration of 5 m.s⁻²
 seismic resistance 6 degrees of Richter's scale
 Self-locking: declared in range 0% to 100% of rated thrust
 Motor's thermal protection: through the Thermik 01.135.5 thermo-contact

Electric control:

remote control - movement of output part of the electric actuator is controlled :

- by binary inputs 24 V DC, or
- by unified input signal 0/4/12 to 20 mA, 4 to 12 mA resp. 20 to 0/4/12 mA, 12 to 4 mA (0/2 to 10 V resp. 10 to 0/2 V), according to version
- potentially controlled through a interface with Modbus/Profibus communication protocol

Power supply of electronics:

- Power supply Z2, resp. ZS is used for single phase versions and feeds the electronic modules built in EA.
- It provides the 24V DC, 40 mA output voltage (according to version).

Power sources contain a protective fuse with parameters according to chapter 1.9.2 Troubleshooting.

Position scanning:

- contactless absolute magnetic.

End positions adjustment:

End position relays are adjusted to the specified stroke with accuracy of ± 0.5 mm.

It is possible to set up (with buttons situated on the control unit, resp. with buttons situated on the local control, resp. program after connecting the EA with PC) the shutting off in end positions as follows:

- Z = Torque + O = Torque
- Z = Torque + O = Position
- Z = Position + O = Torque
- Z = Position + O = Position

Notes:

C = Torque - shutting off at end limit - thrust „Closed“

O = Torque - shutting off at end limit - thrust „Opened“

C = Position - shutting off at end limit - position „Closed“

O = Position - shutting off at end limit - position „Opened“

Factory's setup of shutting off in end positions is described in the chapter "Adjusting of actuator".

Thrust scanning: - using thrust switches S1 and S2.

Thrust switches adjustment:

Thrust switches switch-off in the interval stated in the Specification table and they cannot be adjusted by user.

Thrust blocking:

The switching-off from thrust can be blocked within a certain range of the stroke starting from a stroke end position (max..5%), for time agreed on, in range of 0 to 20 sec..

Output relay (according to version) :

- 3x relays (standard) (standard for DMS3 without version Modbus/Profibus) (**READY, R1, R2**) max. 250 V AC/1 A/cos phi=1; max. 30 V DC/2A
- 3x additional relays (options) (**RE3, RE4, RE5**) max. 250 V AC/1 A/cos phi=1; max. 30 V DC/2A
- 6x additional relays (options) (**RE1, RE2, RE3, RE4, RE5, READY**) max. 250 V AC/1 A/cos phi=1; max. 30 V DC/2A
- relays **READY, R1, R2, RE1, RE2, RE3, RE4 a RE5** are free programmable (their function can be changed with buttons on the control unit, with buttons on the electric local control, or through a PC with the program).

READY relay: - programme selections option – error indication, error or warning, error or not remote, error or warning or not remote. READY relay factory set is shown in the “Adjusting of actuator” Chapter. Relay READY on the control unit and supply unit are doubled (it is not possible to set different functions on these units).

R1 and R2, RE1, RE2, RE3, RE4 a RE5 relay: - programme selections option – disabled, Position O (position open), Position C (position close), Torque O (torque open), Torque C (torque close), Torque O or Torque C, Torque O or Position O, Torque C or Position C, opens, closes, movement, movement – flasher, to position, from position, warning, control – remote, control – local, (not valid for EA without local control), control OFF, relay READY.

Relay R1 is doubled with relay RE1 and relay R2 is doubled with relay RE2 (it is not possible to set different functions on these units).

RE3, RE4, RE5 relays are independent. Factory setting up of the individual relays is shown in the “Adjusting of actuator” Chapter.

Transmitter (output signal (not valid for Modbus/Profibus version)

Electronic position transmitter (EPV) passive (for single phase versions)- 2-wire connection
(without inbuilt power supply)

Current signal	4 ÷ 20, resp. 20 ÷ 4 mA (DC)
Voltage at connection of EPV passive	18 up to 30 V DC
Load resistance	max. $R_L = 500 \Omega$
Tolerance of value of output signal of electronic transmitter in end positions:	$\pm 0,5 \%^{1)}$
Tolerance of linearity of transmitter.....	$\pm 1 [\%]^{1)}$
Hysteresis of transmitter	max. 1 $[\%]^{1)}$

1) from nominal value of transmitter referred to output values

Galvanic separation..... output signal is galvanically separated from input control signal

Program possibilities of output signal : 4 ÷ 20 mA, 20 ÷ 4 mA. Factory's setup of output signal is described in the chapter “Adjusting of actuator”.

Electronic controller (N) (not valid for Modbus/Profibus version) – actuation by input control signal

Input control signals - analogue:	0 - 20 mA (0 – 10 V according to version)
.....	4 - 20 mA(2 – 10 V according to version)
.....	12 - 20 mA
.....	4 - 12 mA
.....	20 - 0 mA(10 – 0 V according to version)
.....	20 - 4 mA(10 – 2 V according to version)
.....	20 - 12 mA

.....	12 - 4 mA
Input resistor for signal 0/4/12 up to 20 mA. 4 up to 12 mA:.....	Rin = 120 Ω
Input resistor for signal 0/2 up to 10 V.....	Rin = 30 kΩ
Tolerance of controller's linearity:	0,5 %
Dead of controller:	program adjustable within 1 - 10%

Factory's setup of input signal is described in the chapter "Adjusting of actuator".

Version with Modbus interface:

- Modbus, line specification: RS485, two-wire design, half duplex.
- Modbus, Transmission Mode: RTU (8-bit binary data).
- Variants:
 - Single Channel version with cable or component redundancy or with repeater (common address and communication parameters).
 - Duo Channel version with cable or component redundancy or with repeater (common address and communication parameters).
- Address: 1 through 247
- Parity:
 - Even (1 stop bit)
 - Odd (1 stop bit)
 - No (2 stop bits)
- Supported transmission rates:
 - 300 bit/s
 - 600 bit/s
 - 1200 bit/s
 - 2400 bit/s
 - 4800 bit/s
 - 9600 bit/s
 - 19200 bit/s
 - 38400 bit/s
 - 57600 bit/s
 - 115200 bit/s
- Signal delay (repeater):
 - max. 2.67 μs
- Bit edge reduction/extension (repeater):
 - max. 1.67 μs

Version with Profibus interface:

- Profibus, line specification: two-wire design, galvanic separated.
- Variants:
 - Single Channel version.
 - Duo Channel version (simple/redundancy).
- Address 1: 1126
- Address 2: 1126
- Redundancy:
 - Off (for single channel version)
 - Simple (for duo channel version)
- Supported transmission rates:
 - 9,6 kbit/s
 - 19,2 kbit/s
 - 93,75 kbit/s
 - 187,5 kbit/s
 - 500 kbit/s
 - 1500 kbit/s

Control by binary inputs 24 V DC:

- by feeding of 24 V DC to terminals CLOSE and OPEN.

Programming possibilities of binary inputs I1 and I2 (change is possible only through the programme of PC or using buttons local control)

- for the input I1 : DISABLED; ESD; DBL (local releasing - not valid for EA without local control), STOP

- for the input I2 : DISABLED, ESD; DBL (local releasing - not valid for EA without local control), 2P resp. E2P (the EA can undergo control for the opening direction or closing with the controller ON and I2 input activated with 24 V DC voltage supplied to the terminals to OPEN or CLOSE).

Factory's setup is described in the chapter "Adjusting of actuator".

Programmable FAILURE REACTION : OPEN, CLOSE, STOP, SAFE POSITION

Factory's setup is described in the chapter "Adjusting of actuator".

Adjustable elements of electronics:

The EA is possible to adjust with or resetting to different parameters operating the control unit buttons, or with buttons on the local control (according to version), or once it is connected to the PC using the programme and the communication cable connected to the EA control unit communication connector and the EA cover removed.

Space heater (E1)

Space heater - supply voltage:corresponding with motor supply voltage (max. 250 V AC)

Space heater power output: cca 10 W/55°C

Electronic board provides switching of heating element. It is possible to change switching temperatures of the switch from -40°C to $+70^{\circ}\text{C}$ with help of PC and particular software. Factory's setup for shut down of heating element (thermostat) is $+25^{\circ}\text{C}$.

Manual control:

- with manual handle on the upper cover of the EA. Turn the manual handle clockwise to move the output shaft of the EA in the direction "Z – closed".

Output part clearance:max. 0, 5 mm (at 5 % of maximum thrust load)

Grease: see chapter 4.2 Maintenance - extent and periodicity.

1.10.1 Mechanical Connection

- with pillars
- with flanges

Main and connecting dimensions are given in the **dimensional drawings**.

1.10.2 Electric connection**To the terminal board (X, X1, X2) for DMS 3 electronic control:**

- 3 terminals (PE, N, L) on the sourcing board with intersection of connection wire 0,05 - 1,5 mm² for solid wire and for flexible wire. Max. terminal screw tightening torque 0,5 Nm.
- 3 terminals ((2(L1), 3(L2), 4(L3)) – for version with 3- phase electric motor) with intersection of connection wire max. 1,5 mm² . Max. terminal screw tightening torque 0,285 N.m.
- 2 terminals (0 V,+24 V) with intersection of connection wire 0,05 – 1,0mm² for solid wire and for flexible wire. Max. terminal screw tightening torque 0,19 Nm.
- 5 terminals (READY, R1, R2) with intersection of connection wire 0,05 – 1,5 mm² for solid wire and for flexible wire. Max. terminal screw tightening torque 0,5 Nm.
- 10 terminals (COM, CLOSE, OPEN, I1, I2, +IN,-IN,SH,+L,-L) with intersection of connection wire 0,05 – 1 mm² for solid wire and for flexible wire. Max. terminal screw tightening torque 0,19 Nm.
- 6 terminals (COM1, RE3, RE4, COM5, NO5, NC5) - for module 3 additional relays with cross-section of connection wire 0,05 – 1,5 mm² for solid wire and for flexible wire. Max. terminal screw tightening torque 0,5 N.m.
- 11 terminals (COM1, RE1, RE2, RE3, RE4, COM5, NO5, NC5, COM, NO, NC - for module 6 additional relays with intersection of connection wire 0,05 – 1,5 mm² for solid wire and for flexible wire. Max. terminal screw tightening torque 0,5 N.m.

To the terminal board (X3) for DMS3 with MODBUS/Profibus protocol:

Screwless terminals are used, with cross-section of connection wire 0,08 to 2,5 mm². Wire stripping length of the wires for screwless terminals is from 8 to 9mm

- 3 terminals (PE, N, U) – supply voltage for version with single – phase electric motor
- 5 terminals (PE, N, U, V, W) – voltage for version with three – phase electric motor
- 2 terminals (21, 22) – voltage for the 24 V DC control
- 5 terminals (13,14,15,16,17) – terminals for the 24 V DC control (COM,CLOSE,OPEN, I1, I2)
- 6 terminals (1,2,3,4,5,6) – terminals single Channel interface of version Modbus//Profibus
- 6 terminals (7,8,9,10,11,12) - terminals redundant of version Modbus/Profibus (by version)
- 3 terminals (18,19,20) – module relay READY (by version)
- 6 or 8 terminals ((18,19,20),23,24,25,26,27,28,29,30) – module additional relays (by version).

Attention: Thermic resistance incoming wires must be minimum +80°C

Wire cross-section conversion table (mm ² – AWG)	
Wire cross-section	
mm ²	AWG
0,05	30
0,2	24
0,34	22
0,5	20
0,75	18
1,5	16
2,5	14
Tightening torque conversion table (N.m – lbs.-in)	
Tightening torque	
N.m	lbs.-in
0,2	2,7
0,3	4
0,5	7

Cable glands for EA with the DMS 3 electronic control

1 cable gland - M20x1,5 - cable diameter 8 to 14,5 mm

2 cable glands – M16x1,5 - cable diameter 6 to 10,5 mm

Cable glands for EA with the DMS 3 electronic control with Modbus/Profibus protocol

2 cable glands M20x1,5 from control box, diameter of cable 8 to 14,5 mm

2 resp. 4 cable glands EMC M16x1,5 - cable diameter 6,5 to 9,5 mm, diameter of shielding 2,5 to 6 mm.

Protection terminal:

During start-up - during installation of device:

- outside and inside ground terminal must be connected for safe operation of the actuator. The position of the outside and inside ground terminal can be seen in Fig. 2,2a and Fig. 2b. For forcing - in wires in external ground terminal be needed use pliers HP3 for insulated eyelet (firm CEMBRE).

Outside and inside earth terminal are mutually interconnected and identified with a protective grounding symbol.

There must be power switch or motor circuit breaker included to the power supply which must be placed as close as possible to the device, easily accessible to the operator and marked as an disconnecting device of actuator.

The electrical connection is made according to the wiring diagrams inserted or glued to the top cover of the EA.

Fuses:

Actuator power supply board is installed with power supply fuse (F3). Location of the fuse on the power supply board can be seen in Fig.2.

Fuse values and parameters:

Type	Order code	Voltage	Frequency (Hz)	Motor Power / Input (W)	max. current EA (A)	Fuse F3 value
STR 0.1PA 438	438.1-0XXXX/YY	230 VAC	50	15/39	0,3	F 2,5 A / 250 V
	438.1-VXXXX/YY	240 VAC	60	18/48		
	438.1-TXXXX/YY	120VAC	60	18/48	0,6	F 2,5 A / 250 V
	438.1-3XXXX/YY	24 VAC	50	15/39	2,8	T 3,15 A / 250 V
	438.1-JXXXX/YY	24 VAC	60	18/48		
	438.1-2XXXX/YY	3x400 V AC	50	15/40	0,25	F 2,5 A / 250 V
	438.1-NXXXX/YY	3x380 V AC	50	15/40	0,25	F 2,5 A / 250 V

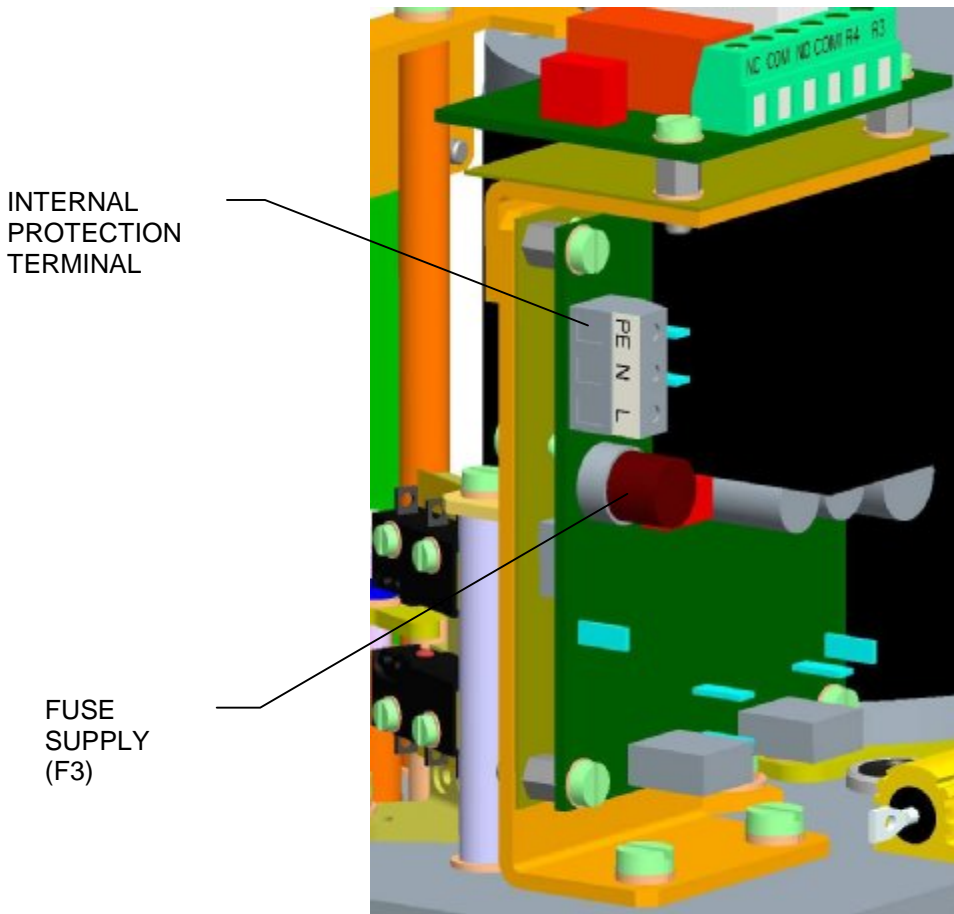
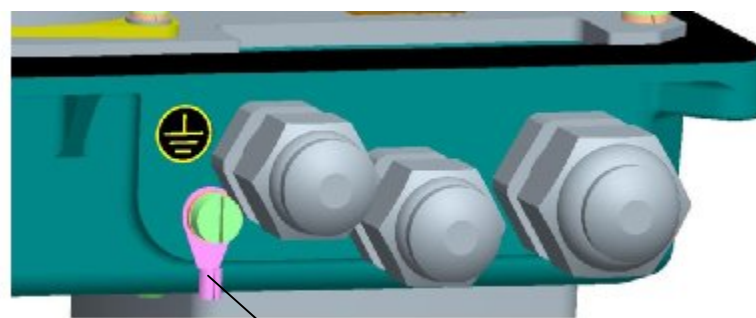
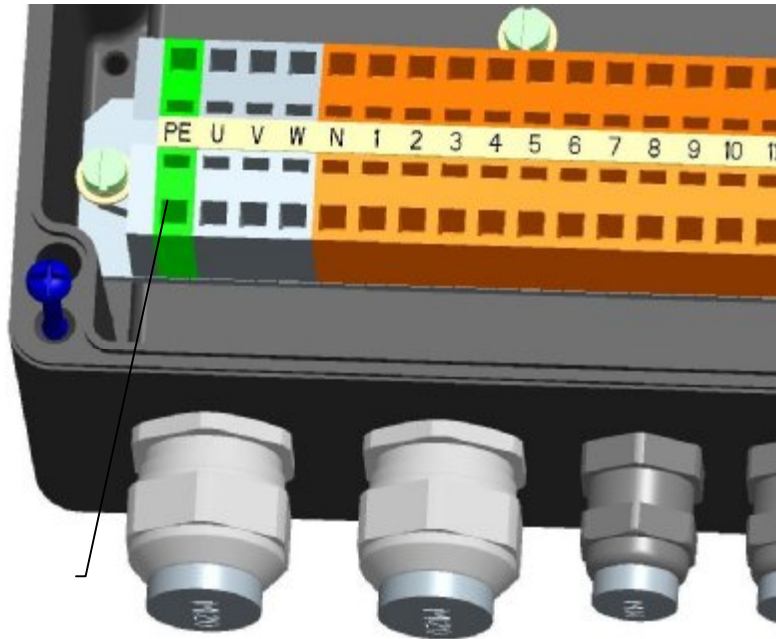

Fig.2



EXTERNAL PROTECTION TERMINAL

Fig.2a



INTERNAL
PROTECTION
TERMINAL WITH
MODBUS
PROTOCOL

Fig.2b

1.11 Conservation, packing, transport, storing and unpacking

Surfaces without surface treatment are treated by conservation preparation MOGUL LV 2-3 before packaging .

Conservation is not necessary if the following storage conditions are complied with:

- Storage temperature: -10 to +50 °C
- Relative air humidity max.80 %
- Electric actuators and their accessories must be stored in dry, well ventilated covered spaces, protected against impurities, dust, soil humidity (by placement to racks, or on palletes), chemicals and foreign interventions
- There shall be no corrosive gases present in the storage areas.

The EA are delivered in solid packages guaranteeing resistance in accordance with EN (IEC) 60 654.

Package is a box. Products in boxes is possible to load on the pallets (pallet is returnable). On the outer side of the package is stated:

- manufacturer nameplate,
- name and type of product,
- number of pieces,
- other data – notices and stickers.

The forwarder is obliged to secure packed products, loaded on transportation means, against self-motion; if open transportation means are used, to secure their protection against atmospheric precipitations and splashing water. Displacement and securing of products in transportation means must provide their stable position, exclude the possibility of their inter-collision and their collision with the vehicle walls.

Transportation can be executed by heatless and non hermetic spaces of transportation vehicles with influences within the range:

- temperature: -25° C up to +70° C (a strange version – 45 ° C up to + 45 ° C)
- humidity : 5 up to 100 %, with max. water content 0.029 kg/kg of dry air
- barometric pressure 86 up to 108 kPa.

Upon receiving of EA examine, if during transportation, resp. storing did not come to its damage. At the same time verify, if the data on the labels corresponds to accompanying documentation and purchase-sale contract / order. Eventual discrepancies, faults and damages should be reported without any delay to supplier.



Electric actuators and their accessories must be stored in dry, well ventilated covered spaces, protected against impurities, dust, soil humidity (by placement to racks, or on palletes), chemicals and foreign interventions, at ambient temperature from -10°C up to +50°C and at relative air humidity max. 80 %.

It is not acceptable to store EA outdoors, or in areas not protected against direct climate influence!

Eventual damages to surface finish remove without delay – thus preventing damage by corrosion.

If storing takes longer than 1 year, it is necessary to inspect lubrication fillings before putting EA into operation and in case of need perform maintenance.

Assembled EA, but not put into operation is necessary to protect by the equivalent method as during storage (for example suitable protective cover).

After assembly to the armature in free and wet areas, or in areas with temperature changes, connect without delay heating resistor – thus preventing damages caused by corrosion from liquefied water in the control area.

Excessive preserving grease remove just before putting EA into operation.

1.12 Assessment of the product and packaging and removal of contamination

The product and its package are made of recycling materials. Do not throw the single parts of the package and of the product after their life but sort them according to instructions in corresponding executives or regulations of environment protection, and allow their recycling.

The product and its packing are not a source of any environment pollution or contamination and do not contain any dangerous waste.

2. Installation and dismantling of actuator

2.1 Installation



Abide by safety measures!

Note: Check again whether the EA is placed in accordance with the Chapter "Operation Conditions". If the installation conditions are different than recommended it is needed to consult the situation with the producer.

Before starting of mounting the EA onto the valve:

- Check again whether the EA was not damaged during storing.
- Check whether the adjusted operating stroke and connecting dimensions of the actuator (see the nameplate) are in compliance with the valve parameters.
- In case of inconsonance, perform adjusting according to the part Adjusting of actuator.

2.1.1 Mechanic connection of electric actuator to the armature

STR 0.1PA electric actuators can be assembled and operated in any position. In horizontal position an actuator with two pillars should be placed with pillars above each other

During assembly must be take care for the space for disassembly of upper cover and with the option to set up elements.

a) Mechanical connection with connection dimensions according to ISO (DIN) Standards (Fig. 3)

Connection procedure:

- Check the labels whether valve and actuator strokes are the same.
- Set the actuator (A) and the valve (B) to the position "closed".
- Put the actuator (A) onto the valve (B).
- Screw the actuator output shaft (2) into the valve coupling (6) until the actuator flange reaches the valve upper body (7).
- Tighten the screws (3) to fasten the actuator flange (1) with the valve upper body (7).
- Check connection dimensions in accordance with dimensional drawing.
- Turn the valve output shaft by one revolution and lock it with the nut (5).

A..... electric actuator
 1..... actuator flange
 2..... actuator output shaft
 3..... screw

B..... valve
 4..... valve output shaft
 5..... lock nut
 6..... valve coupling
 7..... valve upper body

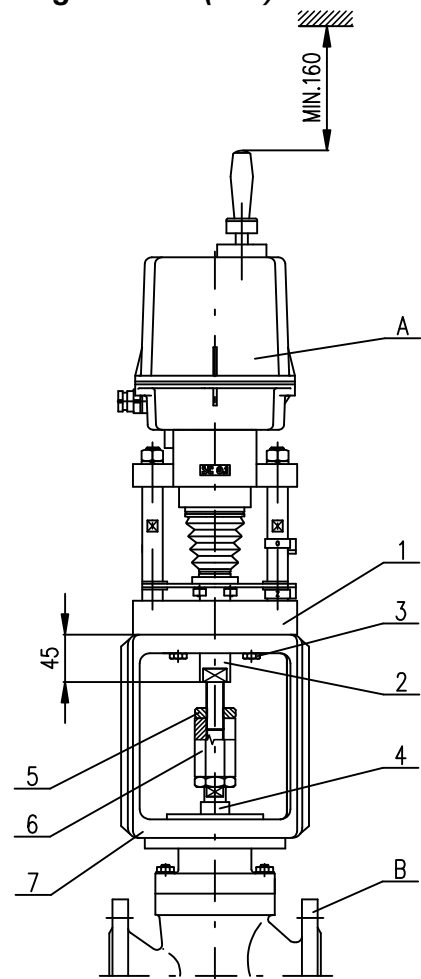

Fig.3

b) Mechanical connection for pillar version - Fig. 4

Connection procedure:

- Check the label whether valve and actuator strokes are the same.
- Put the valve (B) to the position "closed" and the actuator (A) to a mid-position.
- Loosen the screws (2) located on the pillars (4).
- Screw alternatively the pillars (4) into the valve flange (8).
- Fasten the pillar nuts (2).
- Unscrew the coupling screws (3) to dismantle the coupling.
- Screw the coupling nut (1) onto the valve shaft (6) to reach the connection dimension H in accordance with the Table and the actuator label.
- Unscrew the coupling nut (1) by one revolution and lock it with a nut. (7).
- Use the handle (5) to have the actuator output shaft close to the valve shaft (6) and screw the coupling parts together.

- A..... electric actuator
 1 coupling nut
 2 pillar nut
 3 coupling screw
 4 pillar
 5 handle for manual control
- B..... valve
 6 valve shaft
 7 lock nut
 8 valve flange

Order number	H
498.X-XXXXP	110
498.X-XXXXN	57
498.X-XXXXM	27
498.X-XXXXL	80
498.X-XXXXK	42
498.X-XXXXJ	127

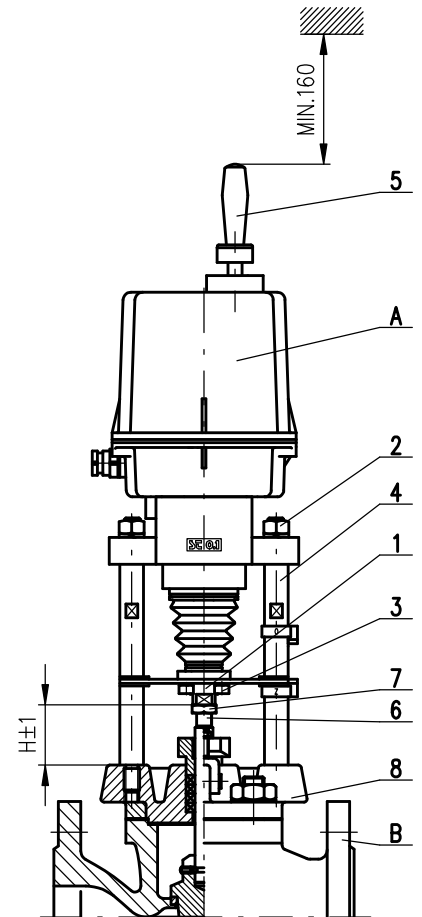

Fig.4

c) Mechanical connection for versions with flange (Fig. 5)

Connection procedure:

- Check the labels whether the actuator and the valve strokes are the same.
- Set the actuator (A) to a mid-position and the valve (B) to the position "closed".
- Put the actuator (B) onto the valve (A).
- Unscrew the coupling screws to dismantle the coupling into parts.
- Screw the coupling nut (1) onto the valve output shaft (3) until the actuator shaft (2) contacts the valve flange (4).
- Connect the flanges with tightening of the central nut (5).
- Check the connection dimension H between the coupling and the flange (2) in accordance with the Table and the type Nr. in accordance with the actuator label.
- Unscrew the coupling nut (1) by one more revolution to the left and lock with the nut (6) to create the prestress onto the valve seat.
- Use the handle to have the actuator output shaft close to the valve shaft (3) and screw the coupling parts together.

- A.....electric actuator
 1coupling screw
 2actuator flange
 B.....valve
 3valve shaft
 4valve flange
 5central nut
 6lock nut

438.X-XXXXV	66
438.X-XXXXH	86
438.X-XXXXG	59
438.X-XXXX4	124
438.X-XXXX3	94
438.X-XXXXF	102
438.X-XXXXE	92
438.X-XXXXD	112
438.X-XXXXC	110
438.X-XXXXB	103
Order number	H

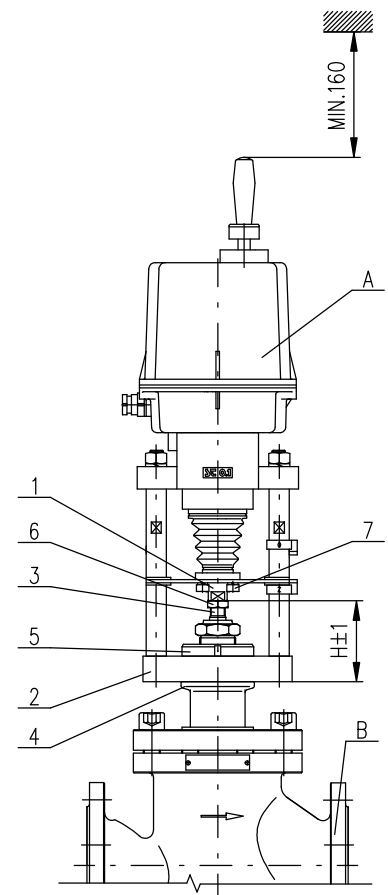

Fig.5

d) Mechanical connection for versions with flange (Fig. 6)

Connection procedure:

- Check the labels whether the actuator and the valve strokes are the same.
- Put the valve (B) to the position "closed" and the actuator (A) to a mid-position.
- Screw up and remove from the actuators flange (7) screws M8x50 (6).
- The actuator with flange (A) put onto the valve (B).
- Screw alternatively screws M8x50 (6) to lock the actuator and valve connection.
- Unscrew the coupling screws (3) to dismantle the coupling.
- Loosed holder of coupling (1) put onto valve shaft (8) in this way that it was possible to plug-in segments (2) into groove of valve shaft.
- Put onto segments (2) and stop tube (4).
- Use the handle (5) to have the actuator output shaft close to the valve shaft (8) and screw the coupling parts together.
- Check correctness of mechanical connection using the handle (5).
- Follow up with electric connection of EA according to wiring diagram placed in top cover of actuator.
- After electric connection perform checking of function.

- A actuator
 1 holder of coupling
 2 coupling segment
 3 coupling screw
 4 stop tube
 5 handle
 6 flange screw
 7 actuator flange
- B valve
 8 valve shaft

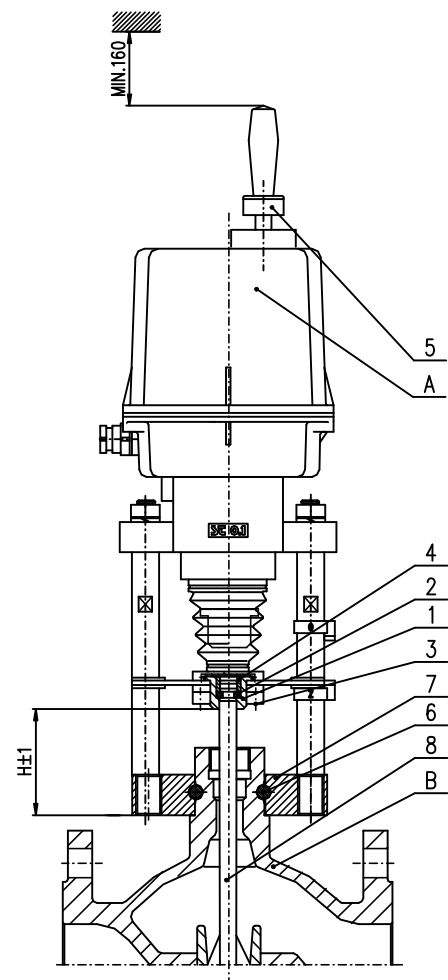

Fig. 6

2.1.2 Electric connection and checking of function

Follow up with connecting the EA with mains or master system.



1. Follow instructions in the part "Requirements for professional qualification"!
2. While laying electrical line abide by the instructions for heavy current installations. Power supply cables must be of the type approved. Minimum thermal resistance of power supply cables and wires must be +80°C.
3. Cables to terminal boards or connectors lead through cable glands.
4. Before putting EA into operation it is necessary to connect inside and outside grounding terminal.
5. Wires of input control signals to controller and output signals from current converter it is necessary to lead them separately with thrust wires or it is necessary to use shielded wires.
6. To prevent moisture from entering the actuator around the connecting cables, the cables must be sealed with silicone material at the point of penetration through device shell.

Connecting with the master system:

EA can be controlled by according to version:

- analogue signals through the built-in position controller
- binary inputs 24 V DC
- with communication protocol Modbus/Profibus

EA is connected according to wiring diagram under the cover of EA.

Notes:

1. Wires of input control signals to controller and output signals from current converter it is necessary to lead them separately with thrust wires or it is necessary to use shielded wires.
2. Together with EA are delivered sealing cable glands which make possible enclosure protection IP68 in case of tight mounting onto supply lead. For required enclosure it is necessary to use rings according to real diameter of cable and required thermal resistance.
3. When fastening the cable it is necessary to count with allowable diameter of bending so it will not be damaged or there will not be deformation of sealing element of cable bushing. Supply cable have to be fastened to solid construction furthest 150 mm from cable glands.
4. Sealing areas of cover of the control part have to be clean before repeated fastening.
5. Reversion of EA is guaranteed when time interval between switch-on and switch-off the power supply for reverse direction movement of output part is min. 50 ms.



In version **STR 0.1PA** it is necessary to do **autocalibration** in operation according by enclosure assure the optimal function.



Abide by instructions of valve producers, whether switching-off end positions is to be realised with position or thrust!

2.2 Dismantling

***Before dismantling it is required to disconnect the EA from power supply!
Do not connect and disconnect live connectors!***

- Disconnect the EA from mains phases.
- Disconnect the leads from the EA terminal boards and loosen the cables from cable glands.
- Loosen the fixing screws of the EA flange and of the coupling and disconnect the EA from the valve.
- While sending the EA to be repaired put it into a package solid enough to avoid damages of the EA during transportation.

3. Adjusting of actuator



Attention! See the Chapter 1.2.3 Requirements for Professional Qualification ...
Keep safety regulations!

EA are delivered adjusted onto parameters according to nameplate from Production plant.

Adjustment is made onto mechanical and electrical connected actuator. This chapter describes how to set up the EA to parameter values within a range applicable for the software. Location of adjustable parts of control board is on **Fig. 7** resp. **Fig.7a**.

Adjusting is possible:

- by operating the control unit buttons (see Fig. 7 resp. Fig. 7a);
- by operating the local control panel buttons (see Fig. 8) – only for the EA s equipped with local control;
- through the programme once the EA is connected to the PC using the communication cable.

For the specific adjustment procedure or individual parameters reset see individual appendixes **74 1053 02, 74 1076 02**.

For facilitating the simple setting of required operation parameters, the control unit is equipped with :

- four setting buttons: **MENU, P, O, C**
- six signal lamps according (LED diode) to **Fig. 7** resp. Fig. 7a.

Status indication by means of LED diodes:

LED ERROR (red) – blinks red in case of failure eventually lights in the parameter setting mode

LED OPEN / MENU (green) – in the ON/OFF mode it lights with a control action for the **opening** direction eventually blinks with accessing the MENU mode

LED CLOSE / PAR (red) – in the ON/OFF mode it lights with a control action for the **closing** direction eventually blinks besides the chosen parameter in the menu and lights up at writing the parameter into the memory

- **LED I1 / SEL** (yellow) – permanent lights with active input I1, or flash in the mode of parameters set up.
- **LED I2** (yellow) – permanent lights with active input I2
- **LED POWER** (green) – it light on at leading the power supply.

For version with Modbus communication

- **LED DEX1** (yellow) – permanent lights during Modbus single Channel communication
- **LED DEX2** (yellow) – permanent lights during Modbus duo Channel communication.

LED for Profibus version

LED DEX1/ERR (yellow/red) - Profibus chanel 1

yellow - permanent lighting by active communication, chanel in DATA Exchange mode

red - permanent lighting by faulty communication, chanel is not in DATA Exchange mode

red - blinking by Fatal Error (necessary to restart an actuator - switch-off and afterthen switch on)

LED DEX2/ERR (yellow/red) - Profibus chanel 2

yellow - permanent lighting by active communication, chanel in DATA Exchange mode

red - permanent lighting by faulty communication, chanel is not in DATA Exchange mode

red - blinking by Fatal Error (necessary to restart an actuator - switch-off and afterthen switch on)

Electronics - programme selections option according to version:

- **relay R1; R2; RE1 to RE5** : disabled; open position, close position, torque-open, torque – close, torque open or torque close, torque open or position open, torque close or position close, open, close, movement, movement flasher, to position, from position, warning, remote control, local control, control shut off, relay READY.

- **relay READY**: errors, errors or warnings, errors or no remote, errors or warnings or no remote.
 - **output signal** (from EPV passive): 4 to 20 mA; 20 to 4 mA.
 - **control (regulating)**: 2P, 3P, 3P/2P I2
 - **input control signal** (N): 0/4/12 up to 20 mA, 4 up to 12 mA or 0/2 up to 10 V.
 - **input I1**: DISABLED, ESD, DBL (local releasing - not valid for EA without local control), STOP
 - **input I2**: DISABLED; ESD; DBL (local releasing - not valid for this type of the EA), 2P resp. E2P (for control programme option 3P/2P I2, or in case of active communication through Modbus/Profibus protocol, allows control using the binary 24V DC inputs with I2 input activated).
 - **FAILURE REACTION**: OPEN, CLOSE, STOP, SAFE POSITION
- The identical functions cannot be set on **I1 & I2** inputs in addition to the OFF state (e.g., if the ESD function is set on **I1** input, it is not possible to select the ESD function on **I2** input at the same time).

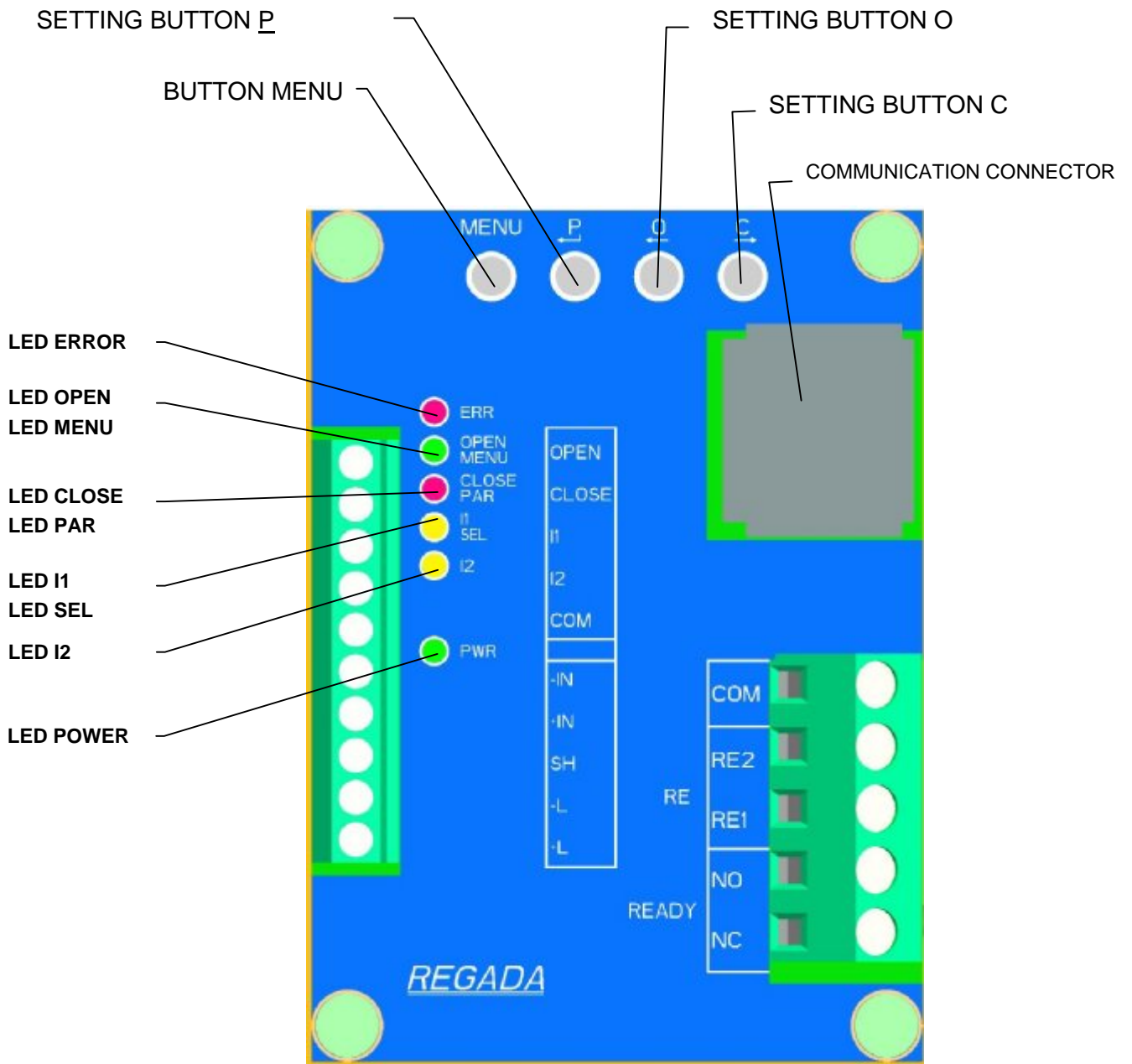

Fig. 7

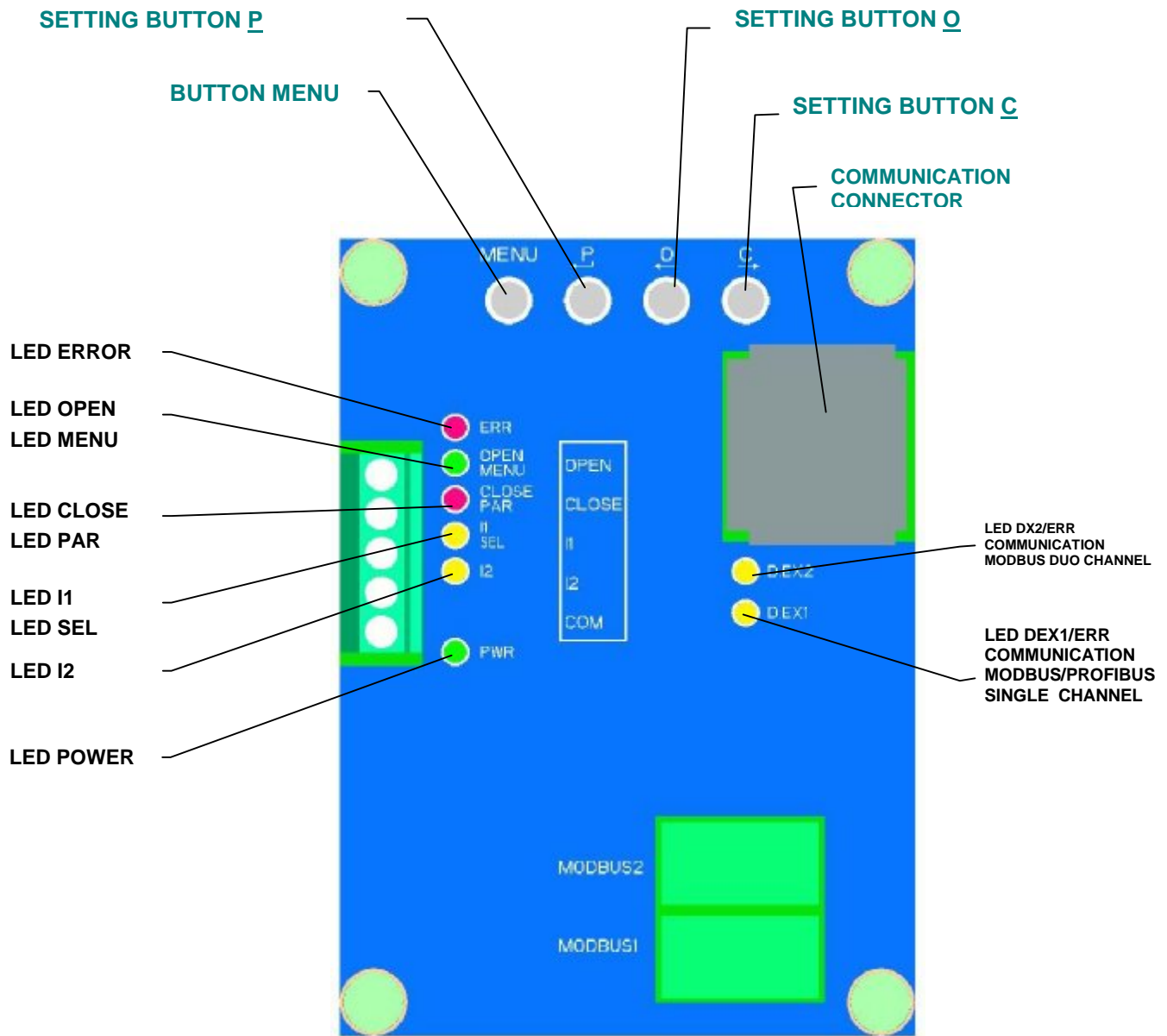

Fig.7a

3.1 EA control set-up options (regulating)

3.1.1 Control setting possibilities for EA's with DMS3 electronic control

2P CONTROL

Setting-up: **2P** control + other functions, in addition to **STOP** on I1 terminal:

The EA moves either to the OPEN or CLOSE direction with **24V DC** voltage supplied to terminals **OPEN** or **CLOSE**. The EA stops if power supply is cut-off or the end position is reached.

2P PULSE CONTROL

Setting-up: **2P** control + **STOP** function on I1:

The EA moves either to the OPEN direction or closes with **24V DC** voltage pulse supplied on connectors **OPEN** or **CLOSE**. The EA stops – shutting off - once the 24V DC voltage is supplied on I1 connector (STOP) or the set end position is reached.

3P CONTROL (REGULATING)

Setting-up: 3P control + other functions, in addition to STOP on I1 and other ones in addition to 2P on I2 input.

The EA moves either to the OPEN or CLOSE direction with **0/4/12 up to 20 mA, 4 up to 12 mA (0/2 up to 10V) input control signal** supplied on terminals **+IN, -IN**. The EA stops once the required position is reached (corresponding with the input control signal supplied) or the set end position is reached.

Note: The ES fails to stop in case that the STOP function is selected on I1 input with 3P control mode and 24V DC voltage supplied on I1 terminal.

3P/2P switched over to I2

Setting-up: **3P/2P** control switched over to **I2** (**2P** function is automatically selected for **I2** input function in selecting this control option) + other functions in addition to STOP on I1:

The EA moves either to the OPEN or CLOSE direction with **0/4/12 up to 20 mA, 4 up to 12 mA (0/2 up to 10 V) input control signal** supplied on terminals **+IN, -IN**. The EA stops once the required position is reached (corresponding with the input control signal supplied) or the set end position is reached.

The EA stops to respond to **0/4/12 up to 20 mA, 4 up to 12 mA (0/2 up to 10 V) input control signal** and rests in case of **I2 active input** (with 24V DC constantly ON or OFF – as per I2 function set-up to ACTIVE – or supplied on I2 connector). The EA is allowed to move either to the **OPEN** or **CLOSE** direction with **24V DC** voltage supplied to terminals **OPEN** or **CLOSE**. The EA stops if power supply is cut-off or the end position is reached. The EA stops to respond to the input control signal and fixes its position once the supply voltage on I2 is OFF.

3P/2P switched over to I2 (PULSE 2P)

Setting-up: **3P/2P control switched over to I2** (**2P** function is automatically selected for **I2** input function in selecting this control option) + other functions in addition to **STOP** on I1:

The EA moves either to the OPEN or CLOSE direction with **input control signal 0/4/12 up to 20 mA, 4 up to 12 mA (0/2 up to 10 V)** supplied on connectors **+IN, -IN**. The EA stops once the required position is reached (corresponding with the input control signal supplied) or the set end position is reached.

The EA stops to respond to **0/4/12 up to 20 mA, 4 up to 12 mA (0/2 up to 10 V) input control signal** and rests in case of **I2 active input** (with 24V DC constantly ON or OFF – as per I2 function set-up to ACTIVE – or supplied on I2 terminal). The EA is allowed to move either to the OPEN or CLOSE direction with **24 V DC** voltage pulse supplied connectors **OPEN** or **CLOSE**. The EA stops once the 24V DC voltage is supplied on I1 terminal (STOP) or the set end position is reached.

The EA stops to respond to the input control signal and fixes its position once the supply voltage on I2 is OFF.

3.1.2 Control setting possibilities for EA's with DMS3 electronic control with MODBUS/Profibus protocol

2P CONTROL (two position controller)

Setting: the two position controller is activated by setting the bit 3P=0 in the corresponding Modbus/Profibus register:

The EA moves in the direction of open or closed **when the bits are set as OPEN, resp. CLOSE in the corresponding Modbus/Profibus register.**

3P CONTROL (three position controller)

Setting: the three position controller is activated by setting the bit 3P=1 in the corresponding Modbus/Profibus register:

The EA moves in the direction of open or closed **in accordance with the requirements sent through the Modbus/Profibus interface.**

EMERGENCY CONTROL

Note: In cases where the EA is equipped with a local control, it is possible to activate the emergency control only if the local control block is set to remote control. The local control block has higher priority than the **ESD** or **E2P**.

- **ESD (Emergency Shutdown)** – is activated when the function parameter is set as **I1=ESD** and the I1 input is activated or when the function parameter is set as **I2=ESD** and the I2 input is activated. The EA takes up the position which corresponds to the settings of the **response to error parameter after input activation**. The **ESD emergency control has higher priority than the E2P control**.
- **E2P (Emergency 2P)** – is activated when the function parameter is set as **I2=E2P** and the I2 input is activated. The **E2P emergency control has lower priority than the ESD control**. Emergency 2P operates in two modes and uses the following inputs:
 - **Permanent signal** – the EA opens or closes only when a signal is present on the **OPEN, CLOSE inputs**.
 - **Impulse mode** – the EA opens or closes after supplying an impulse to the **OPEN, CLOSE inputs**. The EA is stopped after supplying an impulse to the **I1 input**. This mode is similar to the settings of the function **I1=STOP**.

3.2 Procedure for setting individual parameters and the register of errors and warnings

- is given in the separate attachment 74 1053 02 resp. 74 1076 02 of these operating instructions.

The factory default setting of individual programmes shown in Table 2 and Table 3, as long as otherwise specified by the customer:

Table 2

Factory default settings of individual parameters in version without local control; possibility to set-up by operating the control unite buttons.

For the individual parameters set-up see appendix 74 1053 02

MENU			NAME	FACTORY SETTING-UP	
DMS3	MODBUS	Profibus			
1			TORQUE	- it does not apply to this type of EA. The thrust switch is realized by microswitches, the thrust is set at the manufacturer and cannot be changed 100% of the value stated on the type plate for the opening and closing direction	
2			END LIMIT	- C = Position + O = Position - end position switching closed and open from position if valve type is not specified - C = Torque + O = Position - closed in end by thrust position and end position switching open from position for single-seat valves - C = Torque + O = Torque – switching in both end positions by thrust for double-seat valves	
3			TORQUE BLOCKING	- 2 sec. blocking time - 5% blocking position for OPEN & CLOSE direction	
4			RELAY READY	- errors (READY COM-NO relay contacts closed in error free conditions)	
5			RELAY R1...RE5	- position O for relay R1 - position C for relay R2 - from position 95% for relay RE3 - from position 5% for relay RE4 - disabled for RE5 relay	
6	-	-	CPT (output signal)	4 to 20 mA	
7	-	--	REGULATION – (according to specification)	2P	3P
			ANALOG INPUT	-	4 to 20 mA (2 to 10 V)
-	5	-	ADDRESS	2	
-	-	6	ADDRESS 1	2	
			ADDRESS 2	3	
-			BAUDRATE PARITY REDUNDANCY	115200 bit/s EVEN OFF (for single Channel version) COMPONENT (for duo Channel version)	
-	-	7	REDUNDANCY	OFF (for single Channel version) Single (for duo Channel version.)	
8			DEAD ZONE	-	3 %
9			FAILURE REACTION	STOP	

Other parameters set-up is possible to change only by using the PC software

TITLE	FACTORY SETTING-UP
DIRECTION OF ROTATION	clockwise.
THERMOSTAT TEMPERATURE	25 °(space heater OFF temperature)
INTERNAL DEAD ZONE	2 % (only for 3P)
Safe position	0 %
FUNCTION I1	ESD
ACTIVE I1	high level

FUNCTION I2	DISABLED
ACTIVE I2	high level
THERMAL FUSE FAILURE	for this type of electric actuators is inoperative
THERMAL FUSE RESET	for this type of electric actuators is inoperative
CYCLE MODE	DISABLED
CYCLE RUNNING TIME	10 s
CYCLE PAUSE	50 s
CYCLE POSITION O1	0 %
CYCLE POSITION O2	100 %
CYCLE POSITION C1	0 %
CYCLE POSITION C2	100 %
O AND C TOLERANCE	1 %
CREATE BACKUP	START
RESTORE FROM BACKUP	START
RESTORE FACTORY SETUP	START
ACTIVE ERRORS	CLEAR
DIRECTION OF ROTATION	clockwise
CONNECT TIME (Modbus)	3s

Table 3					
Factory default settings of individual parameters in version with local control; possibility to set-up by operating the local control buttons. For the individual parameters set-up see appendix 74 1076 02.					
MENU			FACTORY SETTING-UP		
DMS3	MODBUS	Profibus	NAME		
	1		JAZ/LANGUAGE	English (select language on LCD display)	
	2		POSITION O	work angle range set as per EA specification	
	3		POSITION C		
	4		REG. CALIBR.	START	
	5		END LIMIT	<p>- C = Position + O = Position - end position switching closed and open from position if valve type is not specified</p> <p>- C = Torque + O = Position - closed in end by thrust position and end position switching open from position for single-seat valves</p> <p>- C = Torque + O = Torque – switching in both end positions by thrust for double-seat valves</p>	
	6		TORQUE O	Does not apply to this type of EA - the switching off thrust is not adjustable	
	7		TORQUE C	Does not apply to this type of EA - the switching off thrust is not adjustable	
	8		BLOCK. TIME	2 s	
	9		BLOCK. POS. O	5 %	
	10		BLOCK. POS. C	5 %	
11	-	-	CPT (output signal)	4 to 20 mA	
12	-	-	REGULATION-(according to	2P	3P
13	-	-	ANALOG. INPUT	-	4 to 20 mA (2 to 10 V)
14	16	14	DEAD ZONE	-	3 %
15	17	15	INT. DEAD Z.	-	2 %
16	18	16	FAIL. REACT.	STOP	
17	19	17	SAFE POSIT.	0 %	
18	20	18	FUNCTION I1	ESD	
19	21	19	ACTIVE I1	high level	
20	22	20	FUNCTION I2	DISABLED	
21	23	21	ACTIVE I2	high level	
22	24	22	THERMO. FAIL. (THERMAL FUSE	Thermal fuse active - not functional for this type of EA	
23	25	23	THERMO. RESET (THERMAL FUSE	automatically - not functional for this type of EA	
24	26	24	RELAY READY	errors	
25	27	25	RELAY 1	Position O (POSITION OPEN)	
26	28	26	RELAY 1 POS.	0 %	
27	29	27	RELAY 2	Position C (POSITION CLOSE)	
28	30	28	RELAY 2 POS.	0 %	
29	31	29	RELAY 3	FROM POSITION	
30	32	30	RELAY 3 POS.	95 %	
		31	RELAY 4	TO POSITION	
		32	RELAY 4 POS.	5 %	
33	35	33	RELAY 5	DISABLED (OFF)	
34	36	34	RELAY 5 POS.	0 %	
35	37	35	CYCLE MODE	DISABLED	
36	38	36	CYCLE RUN. T.	10 s	
37	39	37	CYCLE PAUSE	50 s	

38	40	38	OC TOLERANCE	1 %
39	41	39	INFORMATION	TORQUE
40	42	40	RESTORE BACK.	START
41	43	41	CREATE BACK.	START
42	44	42	RESTORE FACT.	START
43	45	43	ACTIVE ERR:	CLEAR
-	-	44	DIRECTION OF ROTATION	clockwise
-	11	-	ADDRESS	2
-	12	-	BAUDRATE	115200bit/s
-	13	-	PARITY	EVEN
-	14	-	REDUNDANCY	OFF (for single Channel version) COMPONENT (for duo Channel version)
-	15	-	CONNECT TIME	3s
-	-	11	ADDRESS 1	2
-	-	12	ADDRESS 2	3
-	-	13	REDUNDANCY	OFF

Other parameters set-up is possible to change only by using the PC software

NAME	FACTORY SETTING-UP
DIRECTION OF ROTATION	clockwise
THERMOSTAT TEMPERATURE	25 °(space heater OFF temperature)
CYCLE POSITION O1	0 %
CYCLE POSITION O2	100 %
CYCLE POSITION C1	0 %
CYCLE POSITION C2	100 %
LCD CONTRAST	0

***Warning 1:** When the input control signal is set to the value 0 , 20 mA (0 to 10 V), or 20 , 0 mA (10 to 0 V) and the input control signal fails, then the EA keeps the position as with a 0 mA (0 V) input signal (EA doesn't recognise between input signal fail and 0 mA (0 V) input signal)- not his does not apply to EA 's equipped with a Modbus/Profibus protocol.*

***Warning 2:** Auto-calibration process doesn't run if triggered in time when the EA is in error state, e.g. EA is overloaded (EA is switched -off from torque). In such case is necessary to resolve issue, e.g. the EA must be moved in a position in which is not switch-off from torque and to start the auto-calibration again.*

***Warning 3:** Calibration process must be performed at any change of the operating angle value of more than 10%.*

***Warning 4:** Operate adjusting button **P** on the control to activate the calibration process or start it from **MENU 4** in the version with local control (use the buttons on local control) or from the programme once the EA is connected to the PC. All calibration start methods have been equal.*

***Warning 5:** In case that EA with supply voltage 3x400V AC after calibration start shows the error „rotation direction“ (error No. 7), it is necessary to stop EA by switching-off the supply voltage and change the phases sequence on the terminals 2 and 3 (change mutually phases wires) and after switching-on the supply voltage run n the calibration agai.*

Rotation direction definition of the electric actuator´s output element

The output rod of the actuator while rotating in the direction “Close“ protrudes from the actuator. It means that the direction of rotation of the actuator is set as **clockwise**.

In case the direction of rotation shall be changed the parater „Direction of rotation of the actuator“ must je adjusted as **anticlockwise**. This parameter can be adjusted through the PC only by use of the EHL Explorer SW. The PC must be connected to the actuator via communication cable and the window “Parameters“ used for direction adjustment.

3.3 Putting an EA into operation when the EA is set up and connected with the armature already in the production plant (starting the calibration)

If EA is delivered from manufacturing plant joined with valve, or with control device, **calibration** must be performed to ensure correct operation, under actual pipeline conditions.

The procedure is as follows:

- fit the given assembly into the specified technology complex
- connect the EA on the supply voltage electrically according to the wiring diagram and chapter Electric connection and checking of function.
- introduce the EA into an mid-position (see Note 2 presented above)
- switch on the supply voltage
- **start the EA calibration** by pressing the **P** button on the control unit **for 2 seconds as minimum** until LED ERROR (red), LED MENU (green) and LED PAR (red) light up – see also the procedure in the separate attachment **No.74 1053 02**
- release the **P setting button**
- after releasing the **P** button the calibration procedure starts – inertia measuring
- after the calibration procedure is finished, the EA is prepared for its operation and starts to response to control inputs
- if changes to some parameters would be necessary, proceed please according to the instructions given in the separate attachment **No. 74 1053 02.**

3.4 Putting an EA into operation when the stroke and parameter setting done by the producer suit to your needs

When an EA is delivered from the producer without armature and the setting of stroke (stroke end positions) and other parameters done by the producer suit Your needs, please proceed as follows:

- connect the EA with the armature to be controlled (**according to chapter 2**) and fit this assembly into the specified technology complex
- connect the EA electrically according to the wiring diagram and chapter Electrical connection and checking of function
- introduce the EA into an mid- position (see Note 2 presented above)
- switch on the supply voltage
- start the EA calibration by pressing the **P** button on the control unit **for 2 seconds as minimum** until LED ERROR (red), LED MENU (green) and LED PAR (red) light up – see also the procedure in the separate attachment No. 74 1053 02
- release the **P** setting button
- after releasing the **P** button the calibration procedure starts
- after the calibration procedure is finished, the EA is prepared for its operation and starts to response to control inputs
- if changes to some parameters would be necessary, proceed please according to the instructions given in the separate attachment No. 74 1053 02.

3.5 Putting an EA into operation when it is necessary to do a change to the stroke (setting new end positions), and the other parameter setting done by the producer suits to your needs

When an EA is delivered from the producer without armature, and the setting of other parameters done by the producer suit to your needs, and it is necessary to do a change to the EA stroke, proceed as follows:

- connect the EA with the armature to be controlled (according to chapter 2) and fit this assembly into the specified technology complex,
- connect the EA electrically according to the wiring diagram and chapter Electrical connection... ,turn on the power supply, without connection of the control signals fed into EA (The EA will report an error i.e. alarm No. 2 or No. 27 (missing input control signal - or Modbus/Profibus activity),
- set the ES (*using manual control**) to end position **closed** and push button **C** **for at least 2s**, until LED ERROR (red), LED MENU (green) and LED PAR (red) come on – the **closed** end position is thus recorded in memory – see description in separate annex **No. 74 1053 02,**
- release the **C setting button,**

- set the ES (*using manual control**) to end position **opened** and push button **O** for at least **2s**, until LED ERROR (red), LED MENU (green) and LED PAR (red) come on – the **opened** end position is thus recorded in memory – see description in separate annex **No. 74 1053 02**,
- **release** the **O setting button**,
- **introduce** the EA into an mid osition (see *Note 2* presented above),
- by pressing the **P** pushbutton on the control unit **for at least 2s** activate the EA calibration until LED ERROR (red), LED MENU (green) and LED PAR (red) come on – see also description of the procedure in separate annex **No. 74 1053 02**,
- release the adjustment pushbutton **P** - upon release of the **P** pushbutton, the calibration process is started,
- turn on the control signals, EA is ready for operation and responds to control inputs,
- if any of the parameters need to be changed, proceed according to the instructions in separate annex **No. 74 1053 02**.

** This applies to the standard setting of menu 9 (in the menu on the control unit) FAILURE REACTION: STOP! If the input control signal is set to one of the ranges starting from 0 mA, it is necessary to change the range to a different one. If this is not the case and a control signal is not supplied, the servodrive output component will take up the position corresponding to 0 mA. After recording the new limit positions change the value of the input control signal and response to error to the required parameters.*

Note: in cases where the sequence is implemented using a PC in the EHL Explorer programme or using local control, neither the change of response to error nor disconnection of the control signals is required.

3.6 Setting other parameters

If changes to some parameters would be necessary, proceed please according to the instructions given in the separate attachment **No 74 1053 02**.

3.7 Error messages from the control unit

The EA electronics makes possible to identify some failures of EA. The failure is signalled by flickering LED ERROR (red) on the control unit (**Fig.7 resp. Fig.7a**). An error has also been indicated on the LED display. An error is indicated on the LCD display in the local control EA version.

The list of errors and warnings compiled by the producer is presented in **table 4** (chapter 4.3).

The list of errors and warnings and the way for identifying a given error as well are presented in the separate attachment **No 74 1053 02**.

A field serviceman is only entitled to change the errors and warnings set using the programme once the EA is connected to the PC.

4. Service and Maintenance

4.1 Service



1. In general it is provided that service of the EA is performed by a qualified worker in accordance with requirement given in Chapter 1!
2. After putting the EA into operation it is needed to verify whether during manipulation any scratch on surface occurred, it is to be removed to prevent actuator against corrosion!

The EA STR 0.1PA requires just negligible service. Proper putting into operation is a recondition of reliable operation.

The service of the EA leads from the operation conditions and usually resides in information processing for further arranging of required functions. The EA can either undergo electric remote control or manual control from the installation site. Operate the service handle for manual control.

The stuff has to perform prescribed maintenance to prevent the EA during operation against impacts of environment, which exceed the frame of allowed influences.

At a power outage or voltage breaking off, an electric actuator will stop in a position, in which it had been before the power outage occurred. In case of need it is possible to preset the electric actuator with manual operation.

Manual control:

If needed (during adjusting, function checking, failure etc.) the stuff can change setting of the controlled body using the handle.

Instructions for manual control:

- Switch the power supply off.
- Turn the button for gear disengagement to the right by 90° (Fig. 11, the button arrow shows the symbol of hand) what disengages the gear in the actuator.
- Set the actuator to the chosen position:

a) For actuators with manual control: push and turn the handle located on the actuator upper cover. While turning counter-clockwisely the valve is turning in the direction "open". Having the valve in the required position turn the button for gear disengagement to the position "motored operation" what engages the gears¹⁾. Put the handle back to its original position.

b) For actuators without manual control - using the fork wrench. Remove top cover, put fork wrench on 6-edged shaft of manual control. While turning counter-clockwisely the valve is turning in the direction "open". After resetting of the valve put the gear disengagement button to the original position¹⁾ and cover the actuator.

¹⁾ After putting the button for disengaging of gearing again to the position of motor operation if the gearing is not connected it is needed to turn the handle to put the gears into mesh.

In case of manual control the set of end positions and transmitter are not detuned.

Electric local control: - additional equipment (Fig.8)

If necessary in the case of accession, function check and so on, it is possible to preset EA or change some parameters by local electric control with secured power feeding.

It is possible to control after removing of the padlock (1). Control mode selection is changed by sequential pressing of the button (2) **REMOTE-OFF-LOCAL** to **"Remote"** **"Shut off"**, **"Local"**, **"Shut off"**, which is displayed on 2 rows LCD (6). Signalling motion and failure of the EA is also indicated by LEDs diode (7).

Mode "Shut off" – it is possible to change some parameters in this mode in particular menus.

Mode "Local" – it is possible to control EA by the local buttons in this mode - (3) **OPEN**, (5) **STOP**, (4) **CLOSE**.

Mode "REMOTE" – it is possible to control EA by the commands from superior remote system

Proceeding in setup of particular parameters in the mode **"SHUT OFF"** is described in the independent amendment No. 74 1076 02, which is delivered together with EA equipped by local electric control.

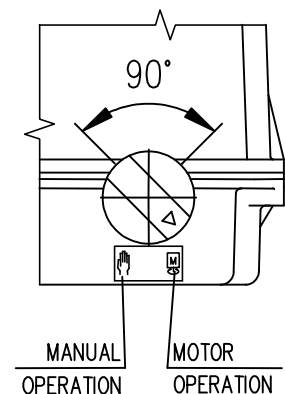

Fig.11

When you finish the work in the “REMOTE” mode put the padlock on the button (2) again. This measure would be received because of potential unauthorized person’s intervention.

Note: Modes of Local or Remote control is conditioned by program choices of inputs I1 and I2. In the case that inputs I1 or I2 are programmed for “Local releasing”, it is only possible to control the EA by local control with active input I1 or I2.

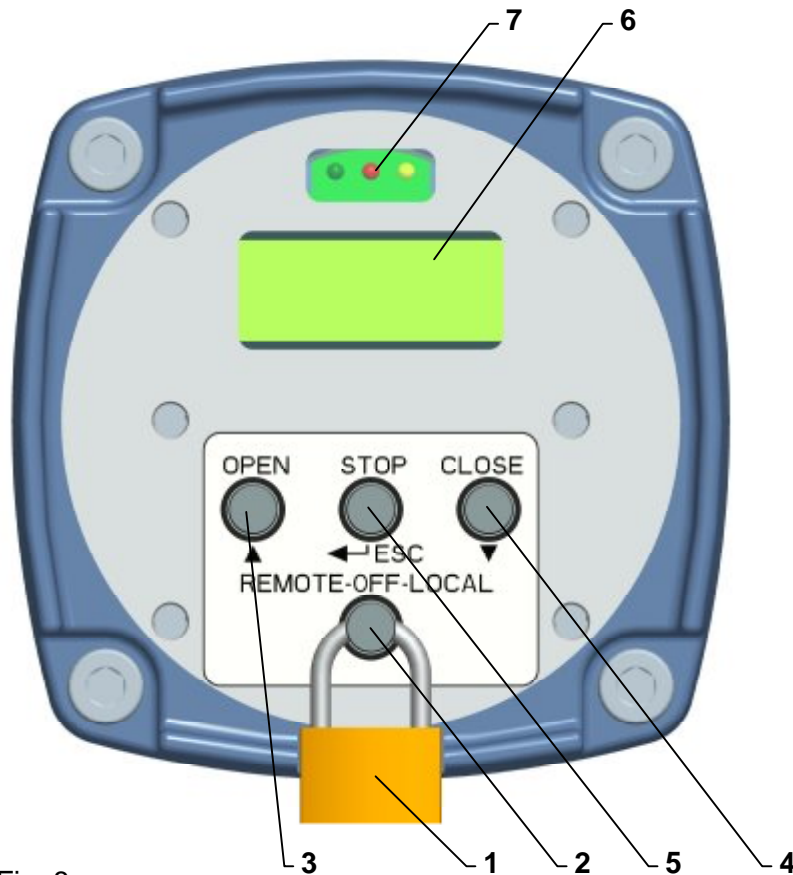

Fig. 8

4.2 Maintenance - extent and periodicity

All screws and nuts affecting tightness and protection (IP) must be tighten during the inspection and maintenance. Similarly, once a year should be checked and if necessary tighten mounting screws of the terminal wires and assuring of the slip-on joints with wires. The internal between two preventive inspections is four years.

In case of damage or after 6 years of the actuator’s operation the replacement of cover seals and oil filling seals must be done.

The grease in the supplied actuators is designed for the lifetime of the product. It is not necessary to change the grease during the operation of the actuator.

Lubrication:

- - gear part – grease HF 401/0 (GLEIT- μ) resp. GLEITMO 585 K
- - linear adapter – grease GLEIT- μ - HP 520M.



Lubrication of the valve stem is independent on maintenance of the EA!

After every potential flooding of the product check, whether there is no water inside. After eventual water penetration, dry the product before repeated putting into operation and replace damaged sealings, resp. other parts of EA. identically check also tightness of cable bushings and replace them, if they are damaged.

- Every six months it is recommended to perform one check move in frame of adjusted operation stroke to verify reliability of functioning with setting back to the original position.
 - If the audit rules do not determine else the inspection of EA is performed ones a year and tightening of all connecting and grounded screws have to be checked to avoid overheating.
 - After 6 months from putting of EA into operation and once a year it is recommended to check tightening of fixing screws between the EA and the valve. (Tighten the screws with the cross system.)
- 
- While connecting and disconnecting of the EA check the tightness of cable glands – those with damaged sealings should be replaced by new ones of the approved type!
 - Keep the EA clean and take care about removing impurities and dust. The cleaning has to be performed regularly according to the operation possibilities and requirements.

4.3 Troubleshooting

At failure of power supply the EA stops in the position where it was before the failure. If needed the EA can be set only with the manual control (the hand wheel). After restoration of power the EA is prepared for operation.

In case of failure of any element of the EA it can be changed by a new one. Entrust the change to a service centre.

In case of an EA failure, which cannot be eliminated directly in operation, follow instructions for under-guaranty and after-guaranty service.

If the EA requires dismantling follow the chapter "Dismantling".

The EA electronics makes possible to identify some failures of the electric actuator. The control unit blinking LED ERROR indicates the failure (**Fig. 7 resp. Fig.7a**) or the error is displayed on the LED (**see Fig. 1**), or the LCD display (**see Fig. 8**). The list of errors and warnings and the way for identifying a given error as well are presented in the separate attachment No 74 1053 02.

The list of errors and warnings compiled by the producer is presented in **table 4**. A change to the list of errors and warnings in the EA is only possible within a service intervention, through the program installed in a PC.

Table 4 setting error flags and warning flags as at the delivery		
PARAMETER	ERROR	WARNING
ESD		X
Analog Input – not valid for Modbus/Profibus protocol		X
Modbus/Profibus activity – only for Modbus/Profibus protocol		X
Wrong command	X	
Torque		X
Torque check		X
Torque calibration	X	
Regulator calibration		X
Stroke (turns sum)	X	
Wrong position	X	
Spin	X	
Spin direction	X	
RAM	X	
ROM	X	
EEPROM		X
Bus	X	
I2C	X	
Reset		X
Voltage +5V		X
Parameters	X	
Set mode		X
Relay		X
Temperature <		X
Temperature >		X
Phase	X	
Power frequency	X	
Thermal fuse	X	
Manual control	X	
Position module	X	
Position module type	X	
Position sensor 1	X	
Position sensor 2	X	
Position sensor 3	X	
Position sensor 4	X	
Torque module	X	
Torque module type	X	
Torque sensor	X	
LED module	X	
LED module type	X	
LCD module	X	
LCD module type	X	
Power Supply/Relay module	X	
Power Supply/Relay module type	X	
E2P	X	
Profibus Channel 1- only for version with Profibus	X	
Profibus Channel 2- only for version with Profibus	X	

Notes: **X** – the error or warning flag is activated.

With the **error flag**, the EA takes the position defined for the FAILURE REACTION function eventually stops (depending on the kind of the error), and it will not operate until the error is removed.

With the **warning flag**, the EA continues in operation.

The user is advised on error or warning through the READY relay (according to the relay setting), by LED ERROR blinking on Control unit, by ERROR message on LED or LCD display, eventually through the program after connecting the EA with a PC

Note 1: In some cases having the error removed the electric actuator must be restarted by switching-off the voltage supply to the electric actuator for about 3 sec.

Note 2 : One of the possible errors may be failure to return disengagement button after the manual control to the position mechanical control. In such case the EA will remain standing.

For repairing eventually the electronics use the fuse – see Fig.2 (F3) for example SHURTER MSF 250, or sub miniature SIBA 164550 xxx (see chapter 1.9.2), which is located on source board.



Taking the EA to pieces for repair purposes is allowed only by professionally qualified persons trained in the production plant or by a contracted service centre!

5. Accessories and spare parts

5.1 Accessories

The EA is delivered with the service handle and communication cable DB-9F/RJ45.

Table 5 Spare part	Order Nr.	Position	Figure
Electric motor; 15W/39 VA; 230/220 V AC; 50 Hz	63 592 314	1	1
Electric motor; 15W/39 VA; 24 V AC; 50 Hz	63 592 356	1	1
Electric motor; 18W/48 VA; 24 V AC; 60 Hz	63 592 061	1	1
Electric motor; 18W/48 VA; 240 V AC; 60 Hz	63 592 059	1	1
Electric motor; 18W/48 VA; 120 V AC; 60 Hz	63 592 058	1	1
Electric motor; 15 W; 230/220 V AC; 50 Hz	63 592 306	1	1
Electric motor; 15 W; 400 V AC; 50 Hz	63 xxx xxx	1	1
Microswitch CHERRY DB 3G B1RB	64 051 198	6	1
DMS3 Z2 24A source board of electronic for 24 V AC	64 051 072	3	1
DMS3 ZS 24A switch – mode power supply for 24 V AC	64 051 103	3	1
Position scanning unit DMS3 SP	64 051 079	4	1
Control unit of the electronics DMS3 J1 (0/4/12 up to 20 mA or 4 up to 12 mA)	64 051 075	2	1
Control unit of the electronics DMS3 J3 (0/2 - 10 V)	64 051 061	2	1
Control unit of the electronics DMS3 J2 (without input and output)	64 051 060	2	1
Control unit of the electronics MODBUS single Channel	64 051 051	2	1
DMS3 M2 - Control unit MODBUS Duo Channel	64 051 052	2	1
DMS3 P1 - Control unit PROFIBUS Single Channel	64 051 037	2	1
DMS3 P2 - Control unit PROFIBUS Duo Channel	64 051 038	2	1
DMS3 L2 LED display	64 051 081	7	1
DMS3 LCD display	64 051 082	6	7
DMS3 H3.4 local control sensor	64 051 084	-	7
DMS3 RE3 Module of additional relays	64 051 065	8	1
DMS3 RE6 Module of additional relays	64 051 066	8	1

Warning: By supplying spare parts, the manufacturer is not responsible for damages caused by their disassembly and assembly. Installation, replacement of spare parts must be performed by authorized, qualified personnel.

6. Enclosures

6.1 Wiring diagrams

Wiring diagrams EA STR 0.1PA for single phase supply

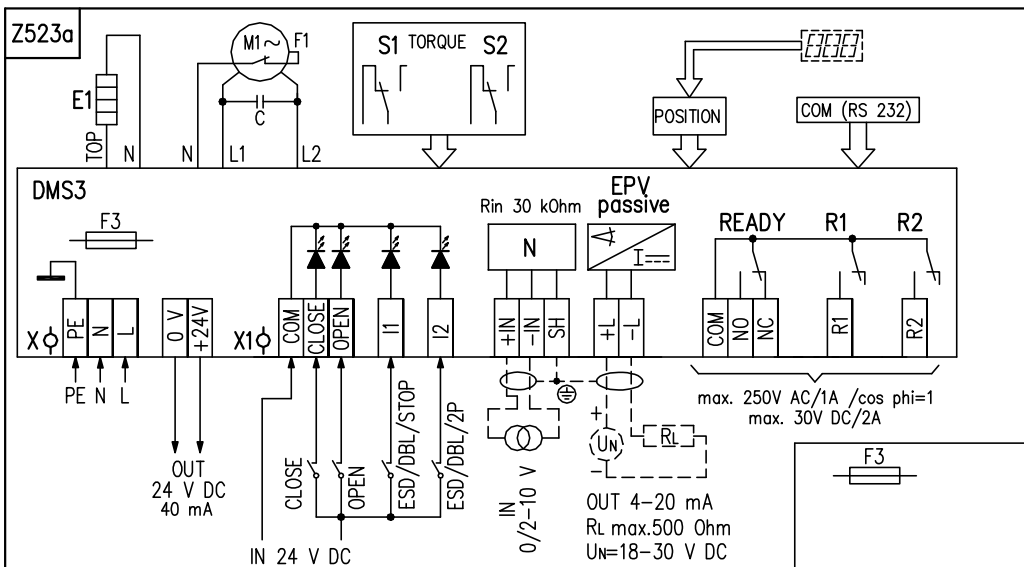
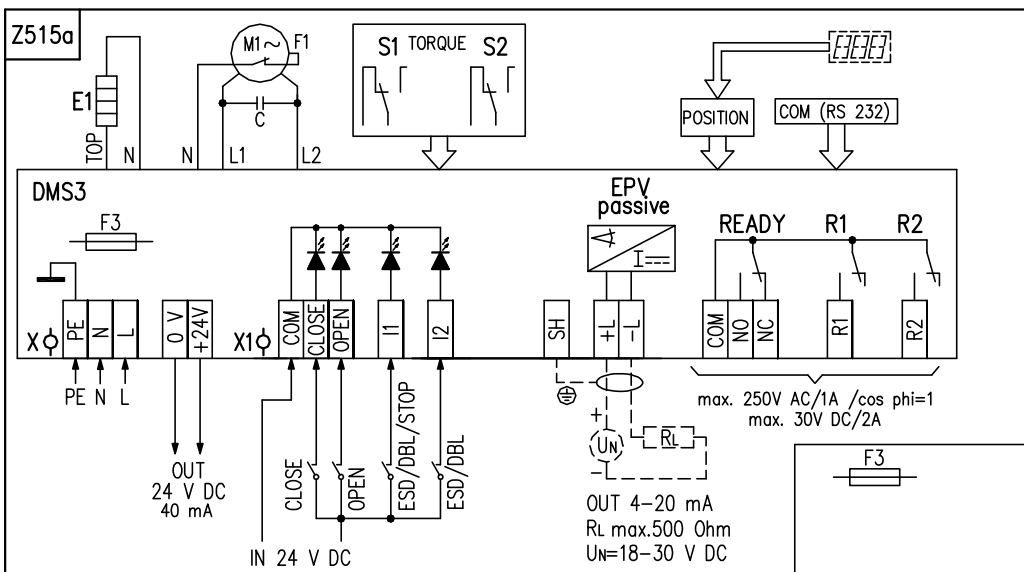
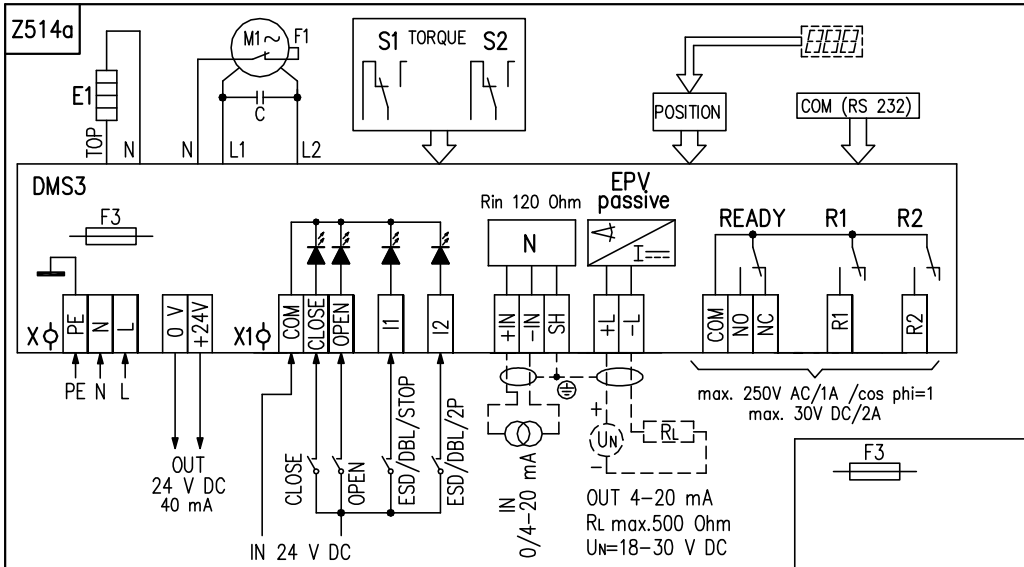

Wiring diagrams EA STR 0.1PA for three phase supply

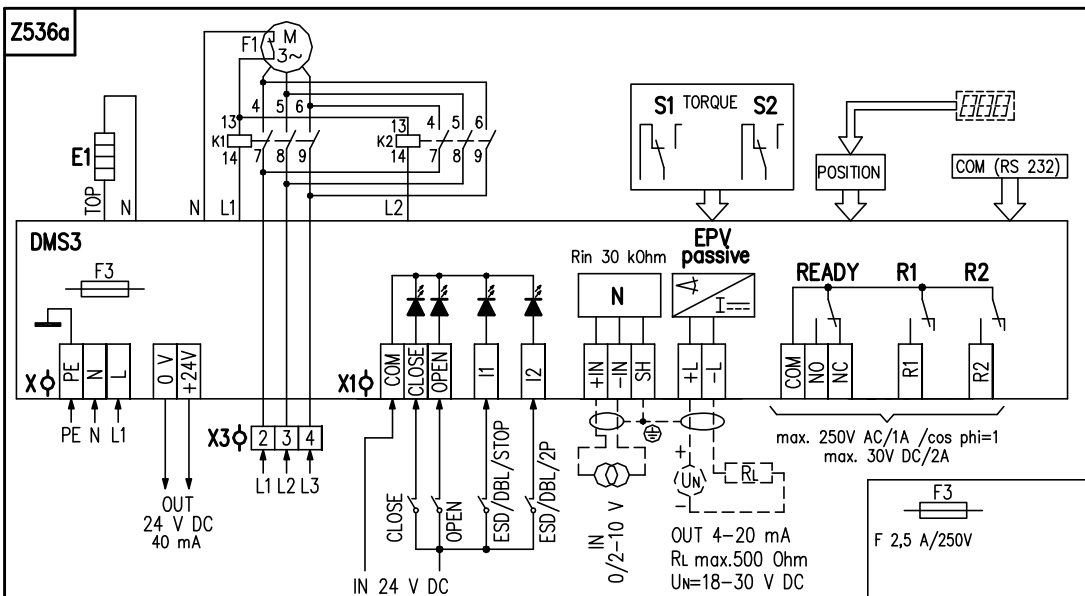
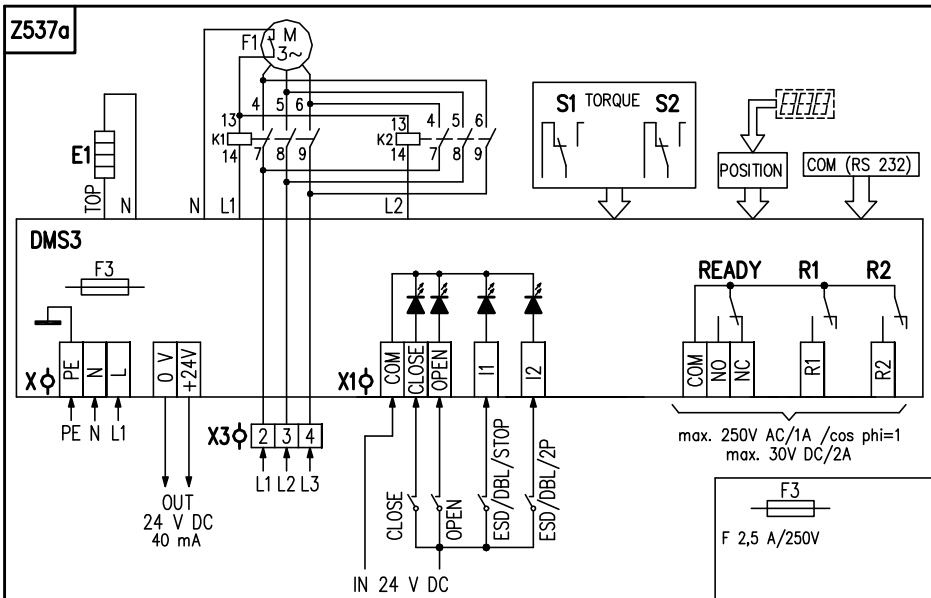
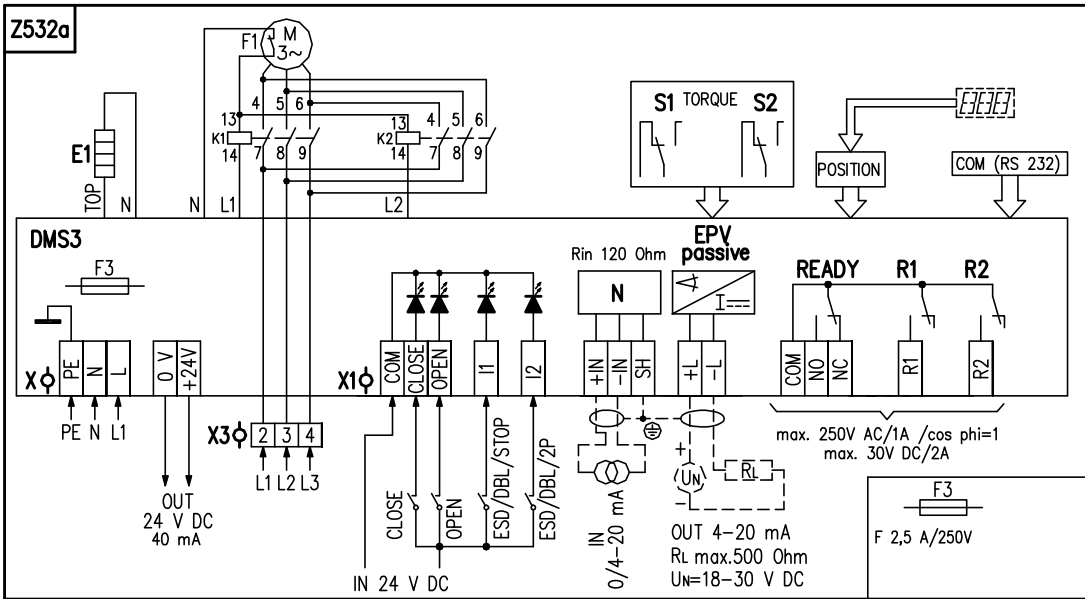

Wiring diagrams EA STR 0.1PA for single phase supply - electric connection to connector

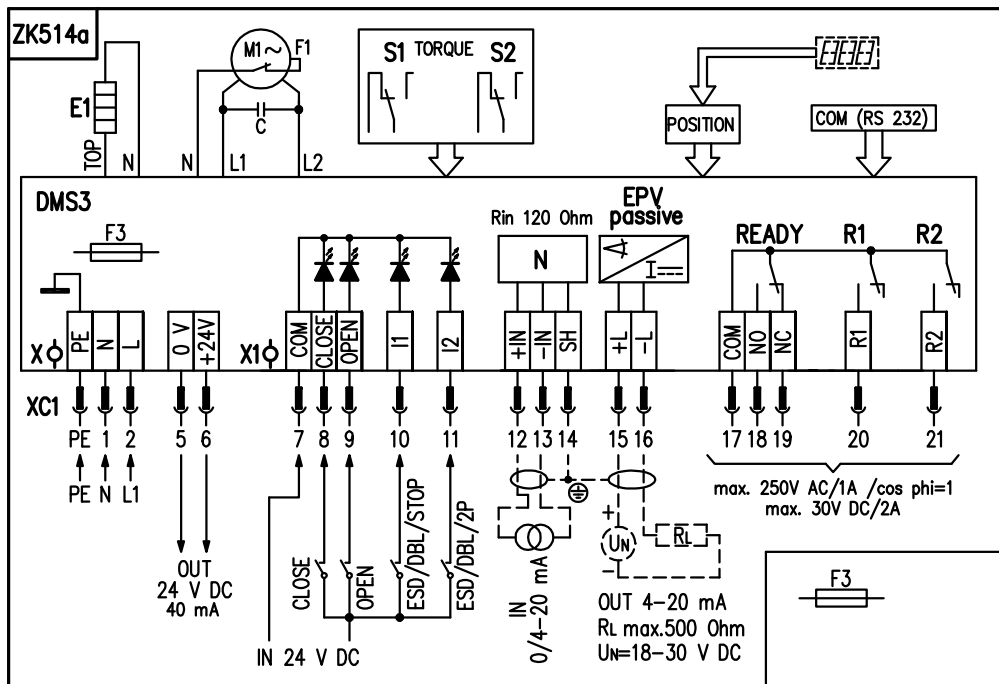

Wiring diagrams for additional relays and local control

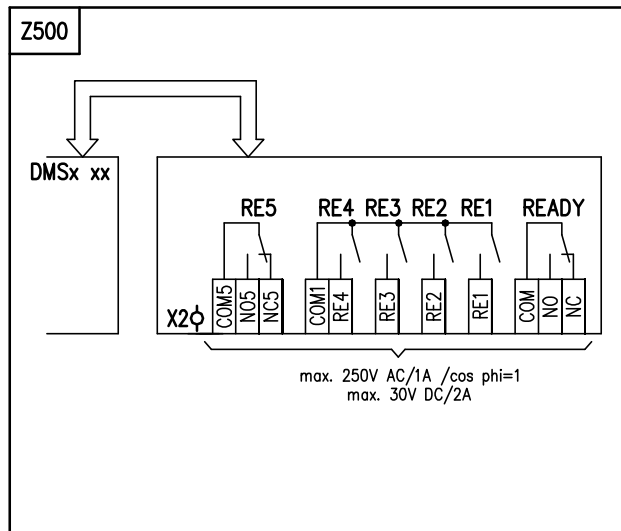
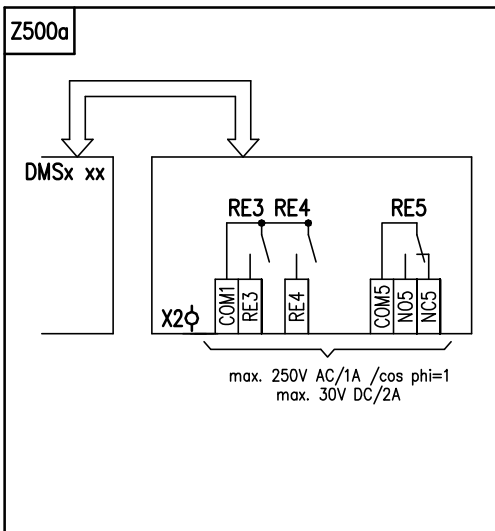
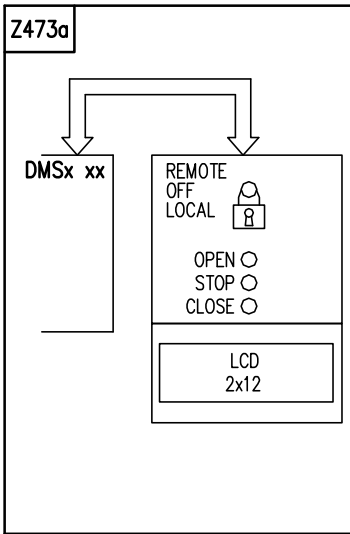

Wiring diagrams for additional relays - electric connection to connector

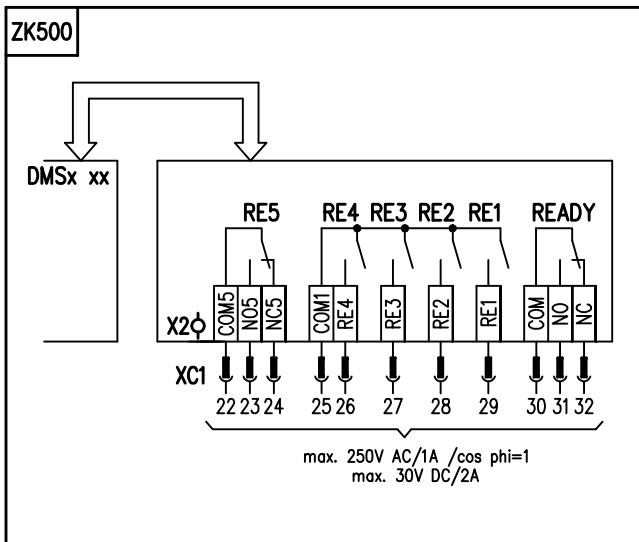

Legend:

Z473a	wiring diagram of electric local control
Z500, ZK 500	wiring diagram module with 6 additional relays
Z500a	wiring diagram module with 3 additional relays
Z514a, ZK 514	wiring diagram of EA STR 0.1PA for the ON/OFF control or for analogue input 0/4/12 up to 20 mA, 4 up to 12 mA and output signal 4 - 20 mA
Z515a	wiring diagram of EA STR 0.1PA for the ON/OFF control
Z523a	wiring diagram of EA STR 0.1PA for the ON/OFF control or for analogue input 0/2 - 10 V and output signal 4 - 20 mA
Z537a	wiring diagram of EA STR 0.1PA with 3-phase electric motor for the ON/OFF control
Z532a	wiring diagram of EA STR 0.1PA with 3-phase electric motor for the ON/OFF control or for analogue input 0/4/12 to 20 mA, 4 to 12 mA and output signal 4 - 20 mA
Z536a	wiring diagram of EA STR 0.1PA with 3-phase electric motor for the ON/OFF control or for analogue input 0/2 - 10 V and output signal 4 - 20 mA
Z574k	wiring diagram of EA STR 0.1PA with 1-phase electric motor with communication protocol MODBUS / PROFIBUS – 2 channel.
Z574m	wiring diagram of EA STR 0.1PA with 1-phase electric motor with communication protocol MODBUS / PROFIBUS – 1 channel.
Z574n	wiring diagram of EA STR 0.1PA with 3-phase electric motor with communication protocol MODBUS / PROFIBUS – 2 channel..
Z574p	wiring diagram of EA STR 0.1PA with 3-phase electric motor with communication protocol MODBUS / PROFIBUS – 1 channel..

C	capacitor
COM(RS232)	possibility for connecting the control unit to and PC
EPV passive	electronic position transmitter is passive with output current signal
E1	space heater
F1	motor's thermal protection
F3	fuse of voltage supply source
K1, K2	coil of relay
M	single phase electric motor
N	controller
POSITION	position scanning
R _{in}	input resistance
R _L	load resistance
U _N	voltage for EPV
R1	free programmable relay
R2	free programmable relay
READY	READY relay (free-programmable)
R1 to RE5	additional relays
S1	thrust switch "open"
S2	thrust switch "closed"
DMS3	electronic module
DMS3 M1/P1	electronic module with Single channel interface Modbus/Profibus
DMS3 M2/P2	electronic module with Duo channel interface Modbus/Profibus
X	voltage supply source terminal board with screw terminals
X1	terminal board with screw terminals on the control unit
X2	screw terminal box on the additional relays board
X3	screw, resp. terminal boards with spring connection (for Modbus/Profibus version)

Terminals for DMS3:

PE, N, L	- terminals (0,05-1,5 mm ²) of supply (24 V AC resp. 110/120 V AC, resp. 230/240 V AC, 50/60 Hz (according to the specification – voltage and frequency are stated on nameplate of EA)
2, 3, 4	- terminals (max. 1,5 mm ²) of supply of supply 3-phase motor 3x400 resp. 3x380 V AC
0 V, +24 V	- terminals (max. 1,5 mm ²) of output voltage 24 V DC (40 mA)
COM, CLOSE OPEN, I1, I2	- terminals (0,05 - 1 mm ²) of control inputs 24 V DC
+IN, -IN, SH	- terminals (0,05 - 1 mm ²) of unified input current signal or voltage signal
+L, -L, SH	- terminals (0,05 - 1 mm ²) of output current signal (passive) 4-20 mA
COM, NO, NC	- terminals (0,05 - 1,5 mm ²) relay READY
COM, R1, R2	- terminals (0,05 - 1,5 mm ²) relay R1,R2
COM1, RE1, RE2, RE3, RE4	- terminals (0,05 - 1,5 mm ²) relay RE1, RE2, RE3, RE4
COM5, NO5, NC5	- terminals (0,05 - 1,5 mm ²) relay RE5

Terminals for DMS3 Modbus/Profibus:

- screwless terminals are in separately terminal box. cross-section of connection wire 0,08 - 2,5 mm²
 PE,N, U - terminals of supply voltage 230 V AC
 PE,N,U,V,W - terminals of supply voltage 3x400 V AC
 1,2,3,4,5,6 - terminals Single channel interface Modbus/Profibus
 7,8, 9,10, 11,12 – terminals Duo channel interface Modbus/Profibus
 21,22 – terminals of output voltage 24 V DC (40 mA)
 13,14,15,16,17 – terminals of control inputs 24 V DC

Note 1: On terminal N, L terminal power supply (X) feed supply voltage 230 V AC, or 24 V AC by you - specified type of construction EA. For supply voltage 24 V AC no need connect ground wire PE. For a version of EA with the supply voltage 3x400 or 3x380V, terminals N, L on terminal board of power supply (X) are fed by power supply 220 respectively 230 V AC.

Note 2: Program possibilities for **R1, R2, RE1, RE2, RE3, RE4, RE5** relays: DISABLED, open position, close position, torque-open, torque – close, torque open or torque close, torque open or position open, torque close or position close, open, close, movement, movement flasher, to position, from position, warning, remote control, local control, control shut of, relay READY.

Program possibilities for **READY** relay: errors, errors or warnings, errors or no remote, errors or warnings or no remote.

Program possibilities for output signal (from **EPV** passive): 4 to 20 mA, 20 to 4 mA.

Control programme options (regulating)(not valid for with Modbus/Profibus protocol): 2P, 3P, 3P/2P switched over to I2

Program possibilities for **input control signal (N)**: 4 to 20 mA (2 to 10 V), 20 to 4 mA (10 to 2 V), 0 to 20 mA (0 to 10 V), 20 to 0 mA (10 až 0 V), 4 až 12 mA, 12 až 4 mA, 12 až 20 mA, 20 to 12 mA

Program possibilities - for Modbus protocol

address – 1 to 247

baudrate [bit/s] – 1200, 2400, 4800, 9600, 19200, 38400, 57600, 115200

parity – even, odd, No

redundancy – off, Cable, Component, Repeater

connect time [s] – 0,1 25,5s

Program possibilities - for Profibus protocol

Address 1 – 1 ... 126

Address 2 – 1126

Redundancy: - Off, Simple

Program possibilities for **inputs I1**: DISABLED, ESD, DBL (local releasing, remote releasing - not valid for EA without local control), STOP.

Program possibilities for **inputs I2**: DISABLED, ESD, DBL (local releasing, remote releasing), STOP

2P, resp. E2P (when controller is switch on)(for control programme option 3P/2P I2, resp. for active communication through Modbus/Profibus protocol) allows control using the binary 24V DC inputs with I2 input activated.

Program possibilities of **FAILURE REACTION**: OPEN, CLOSE, STOP, SAFE POSITION.

The identical functions cannot be set on I1 & I2 inputs in addition to the disabled state (e.g., if the ESD function is set on I1 input, it is not possible to select the (ESD) function on I2 input at the same time.

Relay **READY** on the control unit is doubled with relay **READY** on the module of the additional relays.

Relay **R1** and relay **R2** on the control unit is doubled with relay **RE1** and relay **RE2** on the module of the additional relays.

6.2 Dimensional drawings

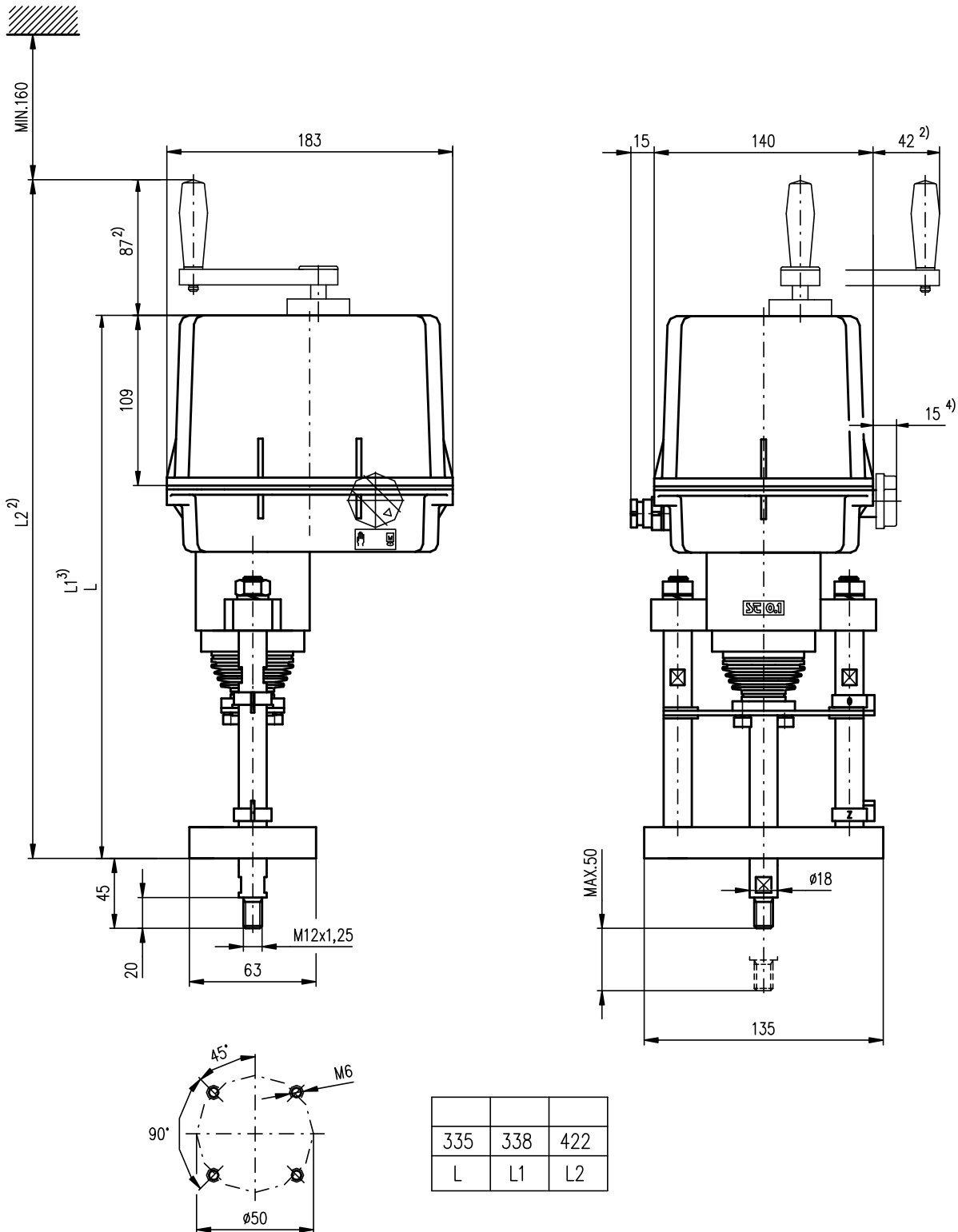

POZNÁMKY \ NOTES \:

2) PLATÍ PRE RUČNÉ OVLÁDANIE S TRVALOU POHOTOVOŠŤOU \ VALID FOR MANUAL CONTROL WITH PERMANENT STANDBY \

3) PLATÍ PRE RUČNÉ OVLÁDANIE BEZ TRVALEJ POHOTOVOSTI \ VALID FOR MANUAL CONTROL WITHOUT PERMANENT STANDBY \

4) PLATÍ PRE RUČNÉ OVLÁDANIE \ VALID FOR MANUAL CONTROL \

VYHOTOVENIE S MIESTNYM OVLÁDANÍM S OVLÁDACOU DOSKOU DMS3 PODĽA P-2045

\ DIMENSIONS OF VERSION WITH LOCAL CONTROL WITH CONTROL BOARD DMS3 ACCORDING TO P-2045 \

P-1201

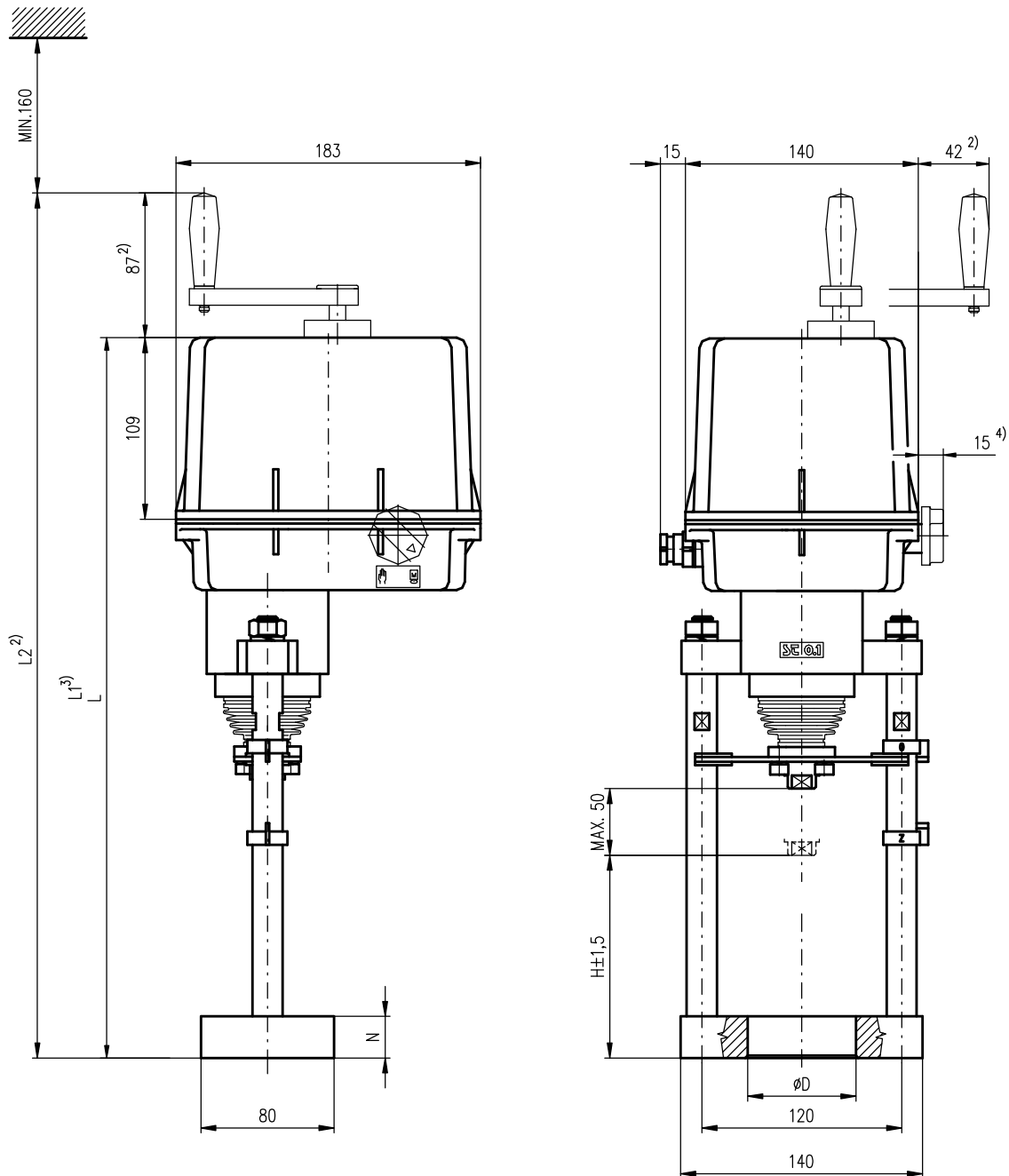

P1202/G	446	449	533	124	58	25
P1202/F	416	419	503	94	58	20
P1202/E	426	429	513	102	57,15	17
P1202/D	416	419	503	92	57,15	17
P1202/C	434	437	521	112	80 H8	–
P-1202/B	434	437	521	110	65,12 H12	25
P-1202/A	425	428	512	103	65,12 H12	25
VYHOT.	L	L1	L2	H	D	N

P-1202/A, B

POZNÁMKY \ NOTES \:

- 2) PLATÍ PRE RUČNÉ OVLÁDANIE S TRVALOU POHOTOVOŠŤOU \ VALID FOR MANUAL CONTROL WITH PERMANENT STANDBY \
- 3) PLATÍ PRE RUČNÉ OVLÁDANIE BEZ TRVALEJ POHOTOVOSTI \ VALID FOR MANUAL CONTROL WITHOUT PERMANENT STANDBY \
- 4) PLATÍ PRE RUČNÉ OVLÁDANIE \ VALID FOR MANUAL CONTROL \

VYHOTOVENIE S MIESTNYM OVLÁDANÍM S OVLÁDACOU DOSKOU DMS3 PODĽA P-2045
 \ DIMENSIONS OF VERSION WITH LOCAL CONTROL WITH CONTROL BOARD DMS3 ACCORDING TO P-2045 \

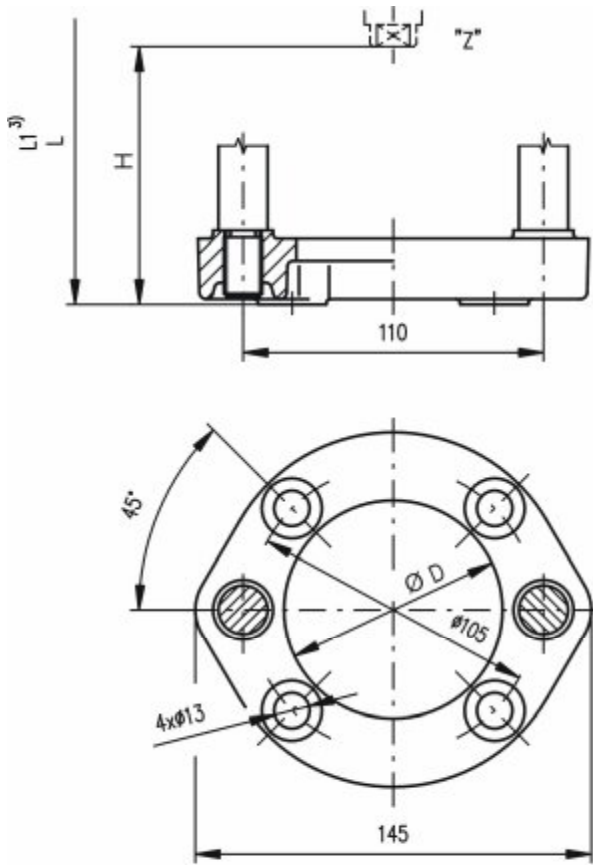

P - 1202/C

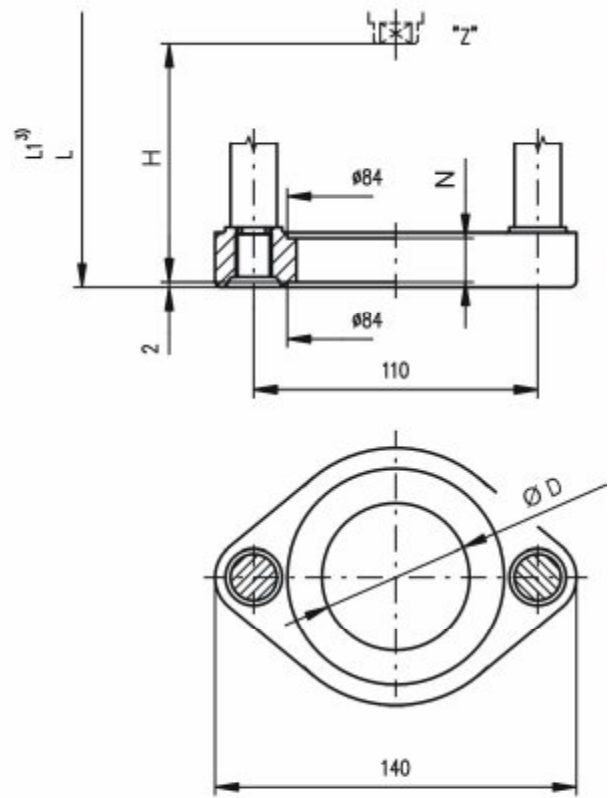

P - 1202/D, E

Rozmery spojky
(Coupling dimensions)

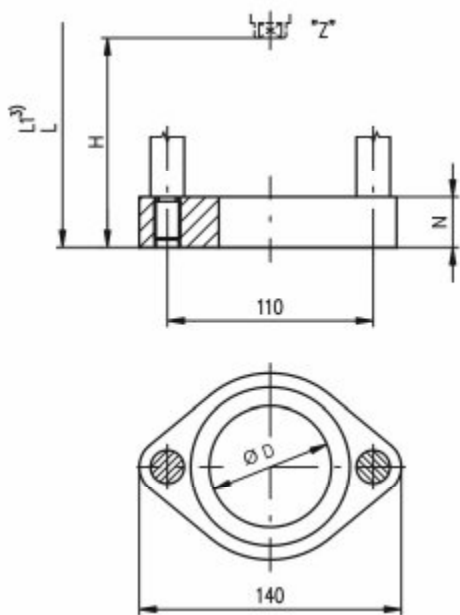

P - 1202/F, G

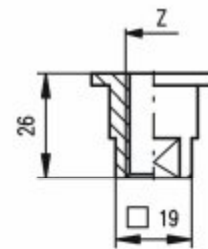

M14	
M12x1.25	
W1/2"	
W3/8"	
W5/16"	
M16x1.5-6H	
M12x1.5-6H	
M12-6H	1/2" - 13 UN
M10x1.5-6H	3/8" - 16 UN
M10x1-6H	5/16" - 18 UN
Z	

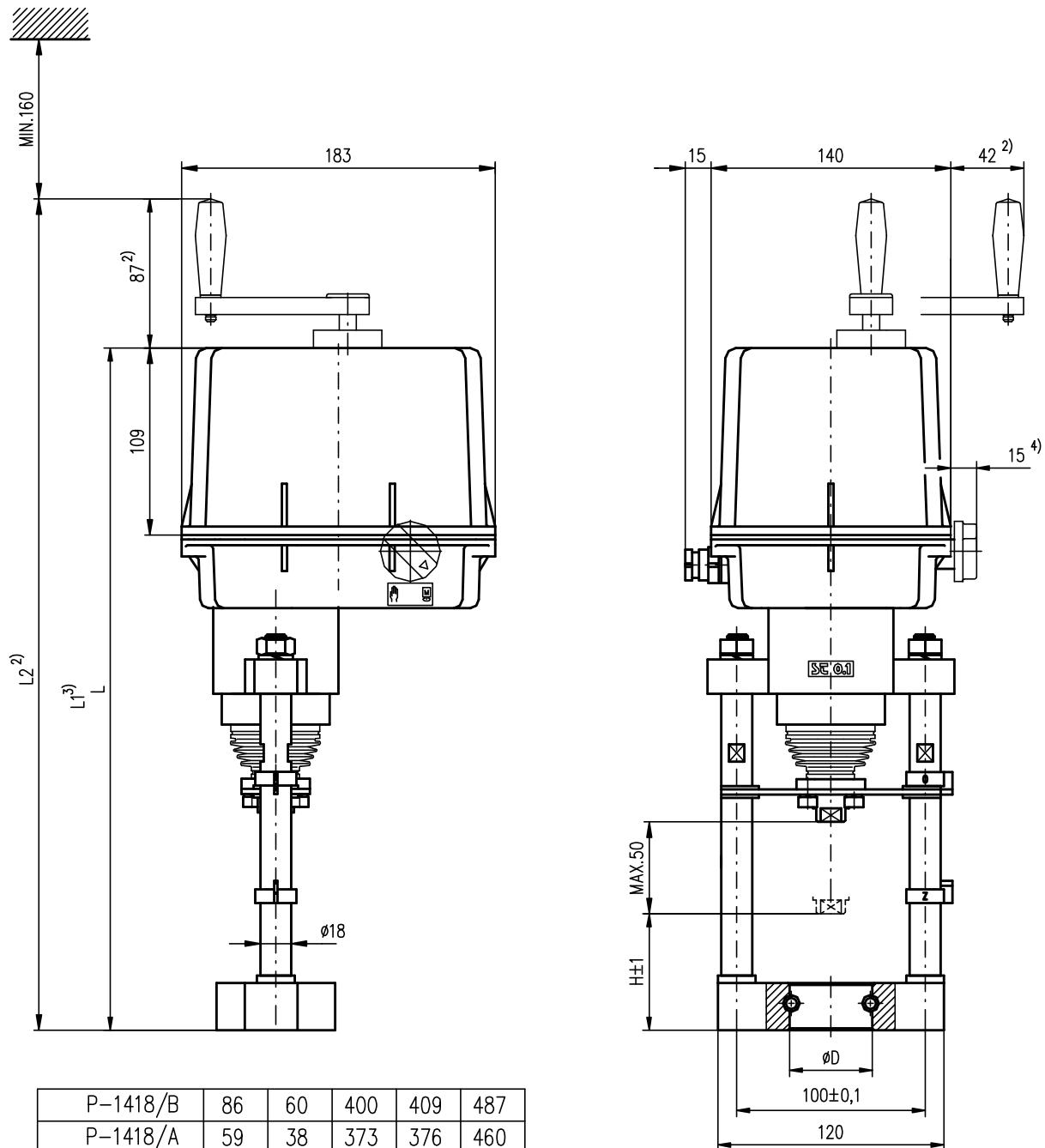

POZNÁMKY \ NOTES \:

2) PLATÍ PRE RUČNÉ OVLÁDANIE S TRVALOU POHOTOVOŠŤOU \ VALID FOR MANUAL CONTROL WITH PERMANENT STANDBY \

3) PLATÍ PRE RUČNÉ OVLÁDANIE BEZ TRVALEJ POHOTOVOSTI \ VALID FOR MANUAL CONTROL WITHOUT PERMANENT STANDBY \

4) PLATÍ PRE RUČNÉ OVLÁDANIE \ VALID FOR MANUAL CONTROL \

VYHOTOVENIE S MIESTNYM OVLÁDANÍM S OVLÁDACOU DOSKOU DMS3 PODĽA P-2045

\ DIMENSIONS OF VERSION WITH LOCAL CONTROL WITH CONTROL BOARD DMS3 ACCORDING TO P-2045 \

P-1418

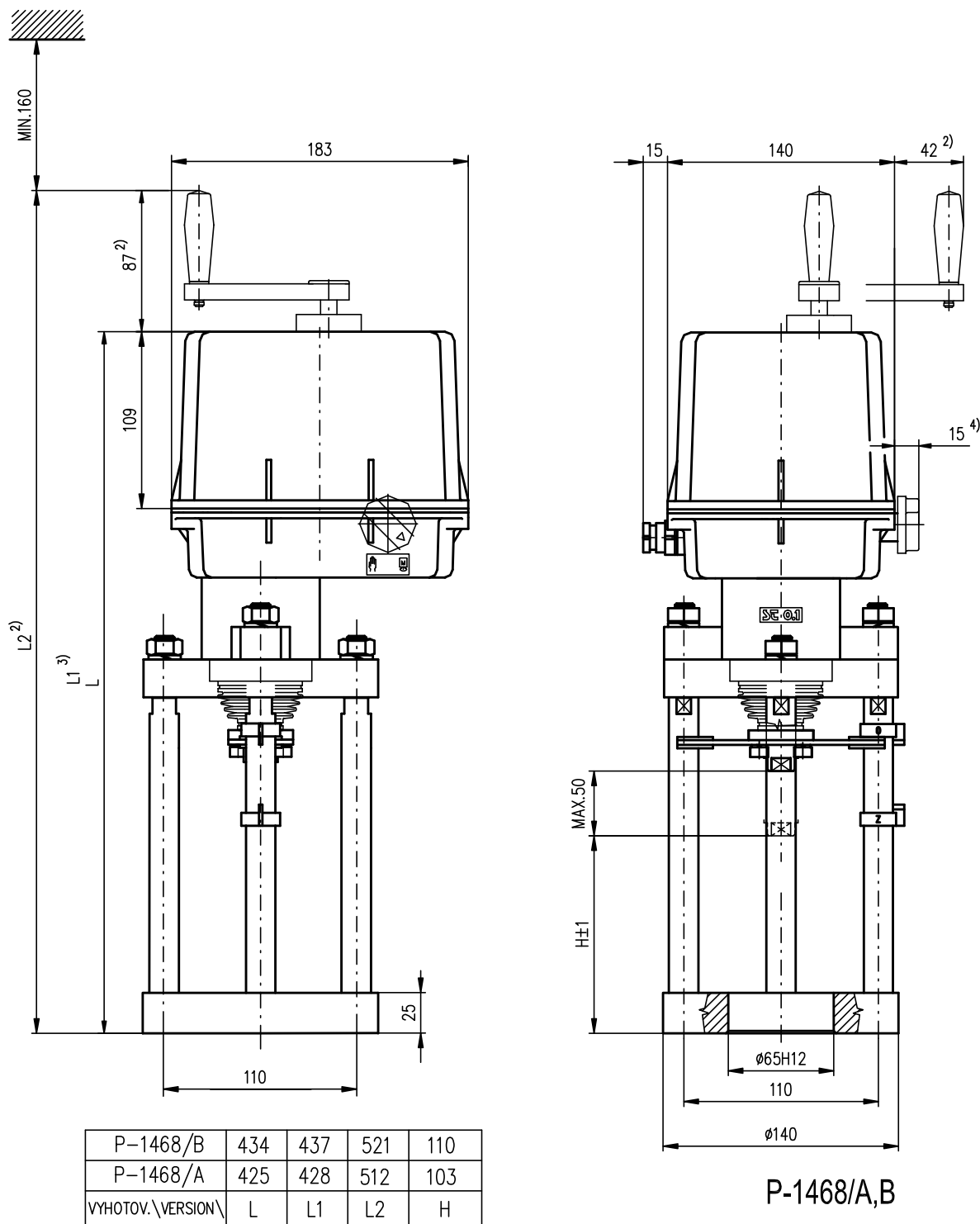

POZNÁMKY \ NOTES \:

- 2) PLATÍ PRE RUČNÉ OVLÁDANIE S TRVALOU POHOTOVOSŤOU \ VALID FOR MANUAL CONTROL WITH PERMANENT STANDBY \
- 3) PLATÍ PRE RUČNÉ OVLÁDANIE BEZ TRVALEJ POHOTOVOSTI \ VALID FOR MANUAL CONTROL WITHOUT PERMANENT STANDBY \
- 4) PLATÍ PRE RUČNÉ OVLÁDANIE \ VALID FOR MANUAL CONTROL \

VYHOTOVENIE S MIESTNYM OVLÁDANÍM S OVLÁDACOU DOSKOU DMS3 PODĽA P-2045
 \ DIMENSIONS OF VERSION WITH LOCAL CONTROL WITH CONTROL BOARD DMS3 ACCORDING TO P-2045 \

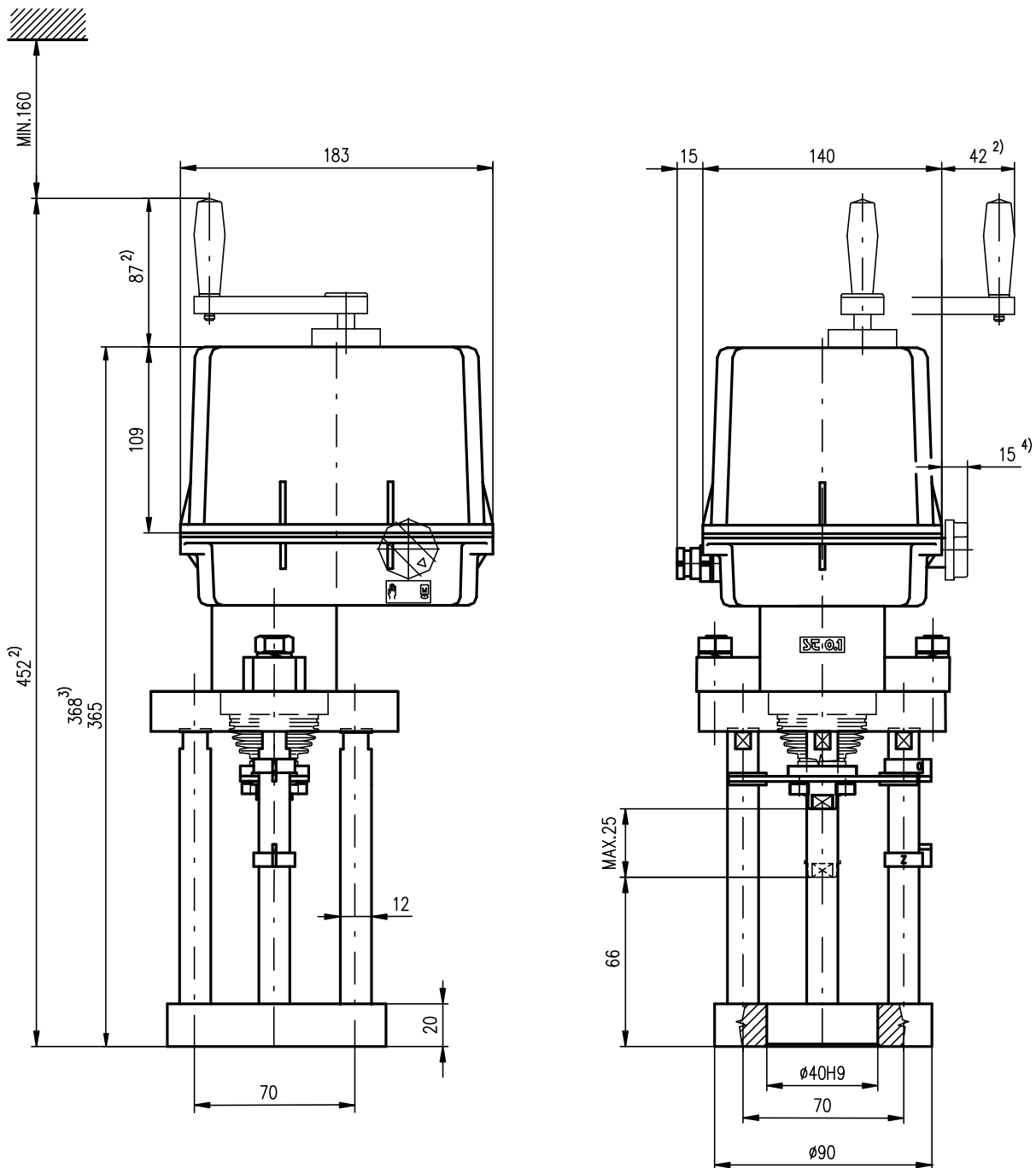

POZNÁMKY \ NOTES \:

2) PLATÍ PRE RUČNÉ OVLÁDANIE S TRVALOU POHOTOVOŠŤOU \ VALID FOR MANUAL CONTROL WITH PERMANENT STANDBY \

3) PLATÍ PRE RUČNÉ OVLÁDANIE BEZ TRVALEJ POHOTOVOSTI \ VALID FOR MANUAL CONTROL WITHOUT PERMANENT STANDBY \

4) PLATÍ PRE RUČNÉ OVLÁDANIE \ VALID FOR MANUAL CONTROL \

VYHOTOVENIE S MIESTNYM OVLÁDANÍM S OVLÁDACOU DOSKOU DMS3 PODĽA P-2045

\ DIMENSIONS OF VERSION WITH LOCAL CONTROL WITH CONTROL BOARD DMS3 ACCORDING TO P-2045 \

P-1470

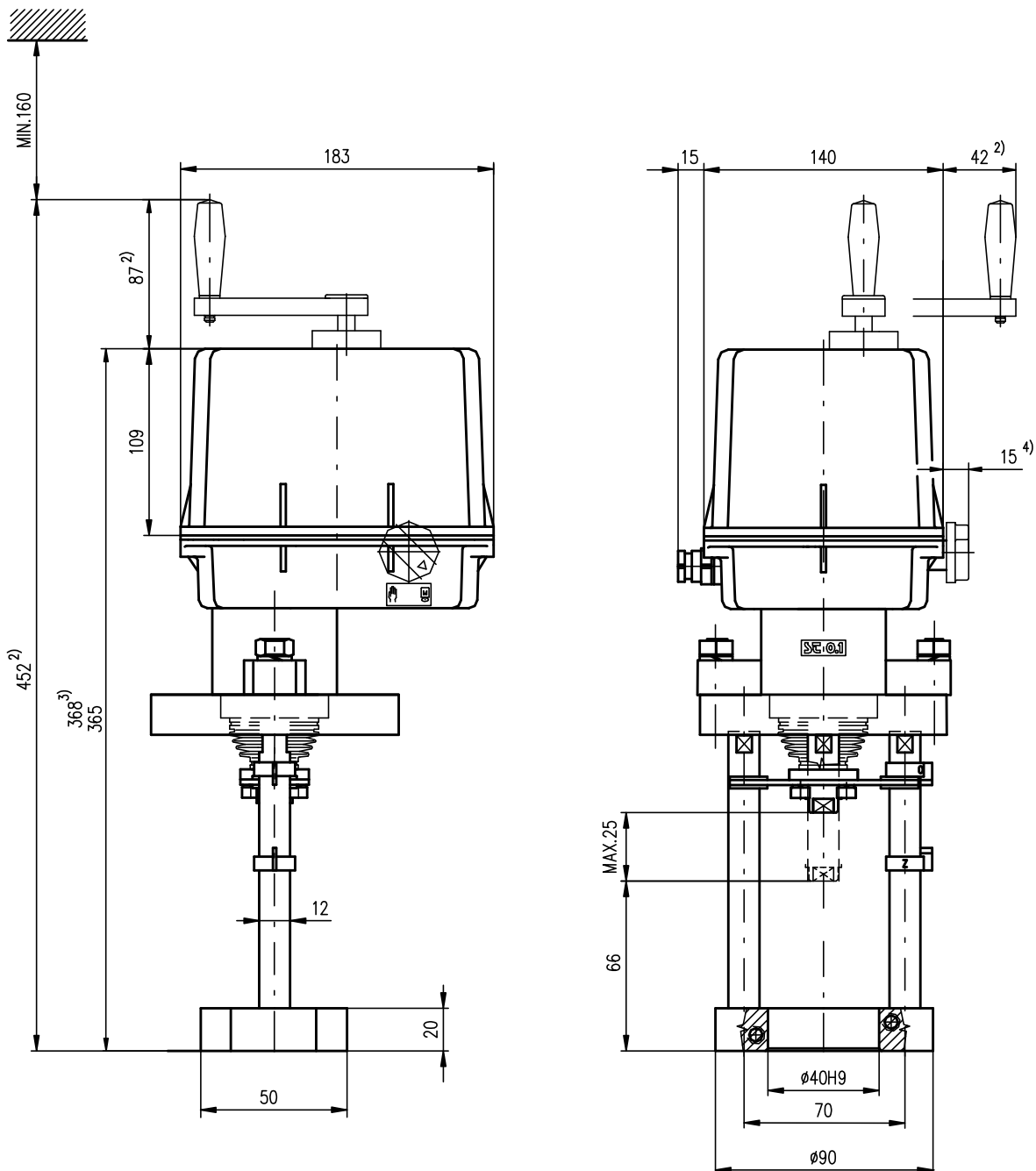

POZNÁMKY \ NOTES \:

- 2) PLATÍ PRE RUČNÉ OVLÁDANIE S TRVALOU POHOTOVOŠŤOU \ VALID FOR MANUAL CONTROL WITH PERMANENT STANDBY \
- 3) PLATÍ PRE RUČNÉ OVLÁDANIE BEZ TRVALEJ POHOTOVOSTI \ VALID FOR MANUAL CONTROL WITHOUT PERMANENT STANDBY \
- 4) PLATÍ PRE RUČNÉ OVLÁDANIE \ VALID FOR MANUAL CONTROL \

VYHOTOVENIE S MIESTNYM OVLÁDANÍM S OVLÁDACOU DOSKOU DMS3 PODĽA P-2045

\ DIMENSIONS OF VERSION WITH LOCAL CONTROL WITH CONTROL BOARD DMS3 ACCORDING TO P-2045 \

P-1472

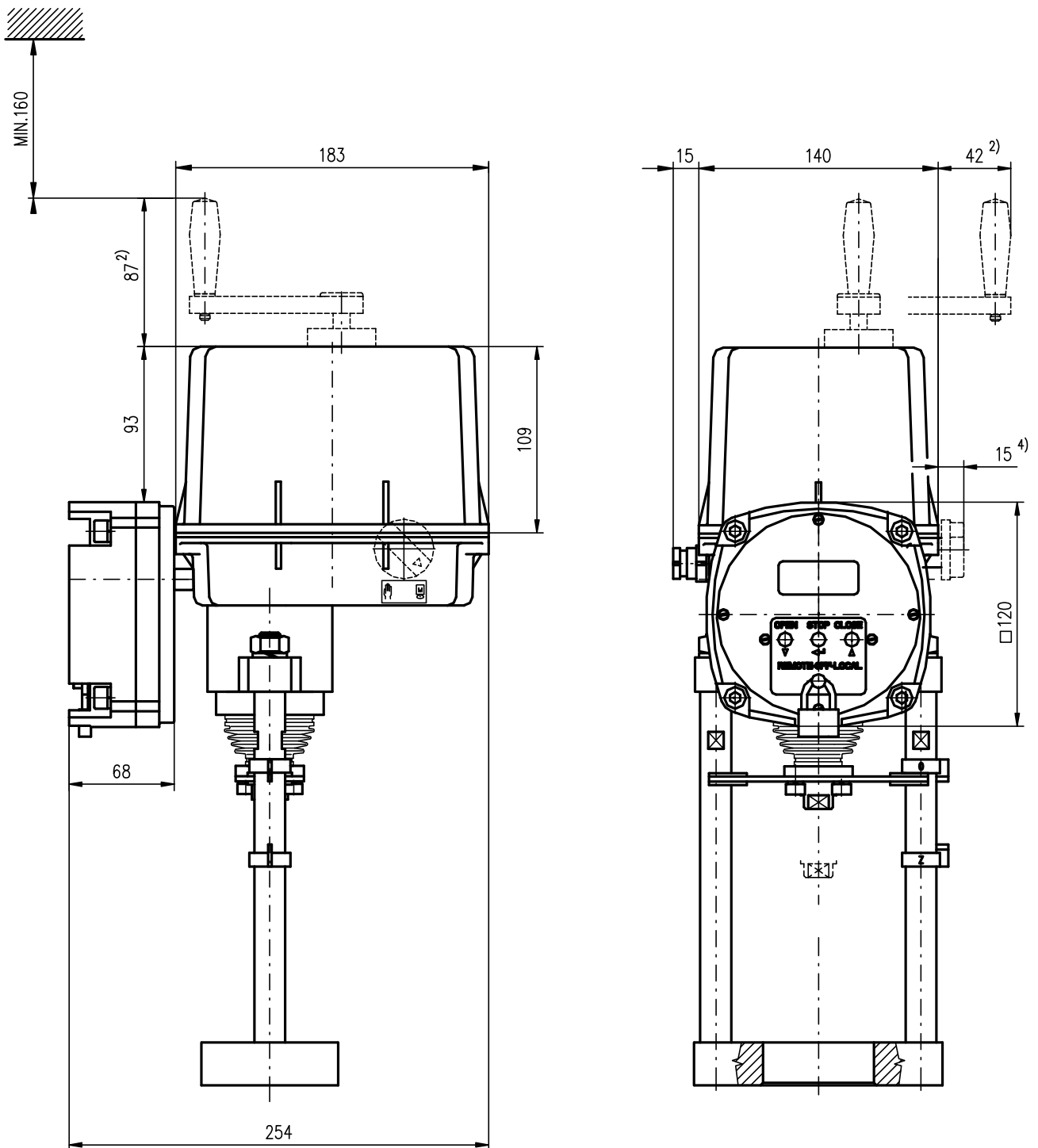

POZNÁMKY \ NOTES \:

2) PLATÍ PRE RUČNÉ OVLÁDANIE S TRVALOU POHOTOVOŠŤOU \ VALID FOR MANUAL CONTROL WITH PERMANENT STANDBY \

4) PLATÍ PRE RUČNÉ OVLÁDANIE \ VALID FOR MANUAL CONTROL \

P-2045

6.3 Guarantee service check report

Service center:D	
Date of repair:	Guarantee repair no.:
User of actuator:	Claim applied by:
Actuator type number:	Actuator production number:
Product claim fault:	Detected product fault:
Used spare parts:	
Remarks:	
Issued on a day:	Signature:

6.4 Post guarantee service check report

Service center:	
Date of repair:	
User of actuator:	Actuator operating place :
Actuator type number:	Actuator production number:
Detected product fault:	
Used spare parts:	
Remarks:	
Issued on a day:	Signature:

6.5 Commercial representation

Slovak Republic:

Regada, s.r.o.,
Strojnícka 7,
080 01 Prešov
Tel.: +421 (0)51 7480 460,
Fax: +421 (0)51 7732 096,
E-mail: regada@regada.sk

Czech republic:

REGADA Česká s.r.o. (Ltd.) – exclusive representation REGADA, s.r.o. (Ltd.) for sale of electric actuators

Regada Česká, s.r.o.
Kopaninská 109
252 25 Ořech
PRAHA – západ
Tel.: +420 257 961 302
Fax: +420 257 961 301