



INSTALLATION, SERVICE AND MAINTENANCE INSTRUCTIONS



***Electric part-turn actuators Rematic
with the DMS 3 electronic control
UPR 1PA, UPR 2PA, UPR 2.3PA, UPR 2.4PA***

TEST CERTIFICATE

EXPLOSION-PROOF ELECTRIC PART-TURN ACTUATOR UPR 1PA, UPR 2PA, UPR 2.4PA, UPR 2.5PA

Type number Power supplyV Hz

Serial number Switching-off torque Nm

Production year Operating time s/90°

Wiring diagram..... Operating angle °

..... Control.....

..... Input operation signal

Warranty period months Output signal

Serial number of electric motor

Serial number of control unit

Tests made by Packed by

Date Signature and stamp

COMPLETENESS CERTIFICATE

Used valve

Assembled by: Firm

Name.....

Warranty period months

Date Signature and stamp

INSTALLATION CERTIFICATE

Location

Installed by: Firm

Name

Warranty period months

Date Signature and stamp

Please read these instructions carefully before mounting and operating the actuator!

Contents

1. General data	2
1.1 Purpose and applications	2
1.2 Safety instructions	2
1.3 Instructions for staff training	2
1.4 Warning for safety use	3
1.5 Data specified on electric actuator	3
1.6 Warranty conditions.....	4
1.7 Under-guarantee and after-guarantee service	4
1.8 Operation conditions	4
1.9 Packing, transport, storing and unpacking	6
1.10 Assessment of the product and packaging and removal of contamination.....	7
2. Description, function and specifications	8
2.1 Description and function	8
2.2 Basic specifications	11
3. Installation and dismantling of actuator	19
3.1 Installation	19
3.2 Dismantling.....	20
4. Adjusting of actuator	21
4.1 EA control set-up options (regulating)	23
4.2 Procedure for setting individual parameters and the register of errors and warnings	24
4.3 Putting an EA into operation when the EA is set up and connected with the armature already in the production plant (starting the calibration)	26
4.4 Putting an EA into operation when the stroke and parameter setting done by the producer suit to your needs	26
4.5 Putting an EA into operation when it is necessary to do a change to the stroke (setting new end positions), and the other parameter setting done by the producer suits to your needs	27
4.6 Setting other parameters.....	27
4.7 Error messages from the control unit	27
4.8 Adjustment of the operating angle position and adjustment of stop screws (Fig.10-14)	27
5. Service and Maintenance	31
5.1 Service.....	31
5.2 Maintenance - extent and periodicity	32
5.3 Troubleshooting.....	32
6. Accessories and spare parts	34
6.1 Accessories	34
6.2 Spare part list	34
7. Enclosures	35
7.1 Wiring diagrams	35
7.2 Dimensional drawings	48
7.3 Guarantee service check report	59
7.4 Post guarantee service check report.....	60
7.5 Commercial representation	61

The Installation, Service and Maintenance Instructions are drawn up according to requirements of EC Executive Nr. 2006/42/EC "Uniform requirements for machines and devices from the point of view of safety and health care", to save life and health of users and to avoid material damages and exposure environment to danger

1. General data

1.1 Purpose and applications

Electric part-turn actuators **Rematic** (hereinafter referred as EA only) with the DMS 3 electronic control of the **UPR 1PA, UPR 2PA, UPR 2.4PA, UPR 2.5PA** (hereinafter referred as **UPR XPA** only) are set up by the program to be controlled on the 24 V DC voltage level, or are set up by the program to be controlled by **analogue input signal**.

EA UPR XPA types are high-powered electric-mechanical products designed for direct installations onto controlled devices (regulating bodies - valves, etc.). EA are provided for remote control of closing bodies or automotive control of regulating bodies in both directions of their movement. They can be equipped with means of measuring and control of technological processes where an unified analogue direct current or voltage signal is an information bearer on their input and/or output. They can be used in heating, energy, gas, air-conditioning and other technological systems, which they are suitable for, regarding their features. They are connected with controlled devices with a flange according to ISO 5211 and a coupling or using a stand and a coupling/a lever.



It is forbidden to use EA as a lifting mechanism!

1.2 Safety instructions

Characteristics of the Product Regarding Its Exposure Rate



EA are reserved technical devices with higher rate of danger (group A), with possibility of installation in areas specially danger regarding casualties caused by electric current.

Electric actuators are according to directive LVD 2014/35/EU and standard EN 61010-1+A1 in the edition in terms of valid certificate, assigned for installation category II (overvoltage category), pollution degree 2.

The product meets the essential safety requirements according to EN 60204-1 and is in compliance with EN 55011/A1 within valid edition.

Product influence to environment

Electromagnetic compatibility (EMC): the product complies with the requirements of the Directive 2014/30/EU of the European Parliament and of the Council on the approximation of the laws the Member States relating to the electromagnetic compatibility and with the requirements of standards as well EN IEC 61000-6-3, EN IEC 61000-6-2, EN IEC 61000-3-2+A1 and EN 61000-3-3+A1, in the edition in terms of valid certificate.

Vibrations caused by the product: product influence is negligible.

Noise produced by the product: The maximum allowable noise level (A) of the product measured in a place of operation is 78 dB (A).

1.3 Instructions for staff training

Requirements for professional qualification of people performing installation, service and maintenance



The electrical connection of the actuator can only be carried out by a person in accordance with legislative requirements of the given country, depending on the required areas of location/use. Service can be performed only by workers professionally qualified and trained by the producer or contracted service centre.

1.4 Warning for safety use



1. Products are assigned for operation in environment consist of gas, steam and vapours, with temperature range: -25°C to $+55^{\circ}\text{C}$ or -50°C to $+40^{\circ}\text{C}$ or -60°C to $+40^{\circ}\text{C}$, with pressure range from 0.8 to 1.1 bar.
2. If the actuator is placed on device which regulate medium with higher temperature than $+55^{\circ}\text{C}$, protect the actuator by additional construction in order to maintain ambient temperature max. $+55^{\circ}\text{C}$ and also to stop temperature transmitting through junction component!
3. Cable glands blinds are assigned only for transport and storage period, i.e. for period till the actuator is builded into operation, than blinds must be replace by connecting cable.
4. In case of not using one of the cable gland, it has to be replaced with a suitable blinding plug.
5. Temperature at the point where the cables enter the actuator can reach max. 90°C . When choosing the connection cables for the actuator, it is therefore necessary to consider this temperature as well.
6. **WARNING !** If it is necessary to operate electric actuator at a temperature of -50°C to -60°C , which has been disconnected from the electrical network, it is necessary to heat the interior of the actuator for 2 hours before applying voltage to the electronics. We start this heating by connecting the supply voltage to terminals "U" and "N" (for EA with DMS3), or to terminal "20" and "N" (for EA with Modbus or Profibus communication protocol), for a period of 2 hours. After two hours of heating, the EA is ready to connect the voltage to the electronics, including the other terminals of the electronics according to the specific wiring diagram. Do not disconnect the heating supply voltage, leave it permanently connected. With this design of the actuator, the temperature of the internal space in the control box is controlled by the thermal switch (F2) and not the electronics of the actuator.

Product protection : There must be included suitable protective device into the power supply (circuit breaker or fuse) which serves at the same time as main switch.

EA UPR PA is provided with its own short-circuit protection of 1 phase motor power supply circuits and space heater. There must be included suitable protective device into the power supply of 3-phase motor (circuit breaker or fuse) which serves as main switch as well. For protection, we recommend to use a fuse type "T" or a contactor type "C".

Supply voltage of 24 V AC/DC EA is provided with its own protection of the DC electric motor supply circuits and it is not provided with protection of the heating resistor circuit against short circuit.

Type of equipment from a connection point of view: The equipment is designed for permanent connection.

1.5 Data specified on electric actuator

Nameplate

Warning plate:

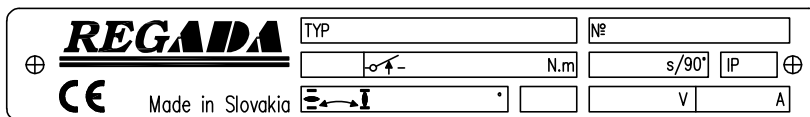

Nameplate contains the basic data concerning identification, performance and electricity: indication of producer, type, serial number, max. load torque and switching-off torque, operating time, protection code, operating angle, supply voltage and current.

Graphic symbols on electric actuator

The graphic symbols used on electric actuator substitute the text messages. Some of them are in accordance with EN ISO 7010, ISO 7000 and IEC 60417.



Dangerous voltage

(EN ISO 7010-W012)

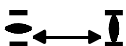

Stroke of the electric linear actuator



Switching-off torque



Manual control

(0096 ISO 7000)



Protection terminal

(5019 IEC 60417)

1.6 Warranty conditions

The supplier is responsible for completeness of the delivery and guarantees these specifications of the product which are stated in the Contract.

The supplier is not responsible for any deterioration of parameters caused by the customer during storage, unauthorised installation or improper operation.

1.7 Under-guarantee and after-guarantee service

Our customers are provided with professional service of our firm in installation, operation, service, maintenance, revision and help in troubleshooting for all our products.

Under-guarantee service is performed by the service department of the production plant, or by a contracted service centre according to a written claim.

In case of occurring of any fault please let us know it and state:

- type code
- serial number
- ambient parameters (temperature, humidity...)
- duty cycle including frequency of switching
- type of switching-off (position or torque)
- set switching-off torque
- type of fault - description of claimed fault
- it is recommended to place also Installation certificate.

It is recommended to have **after-guarantee service** performed by the service department of the production plant, or by a contracted service centre, with national laws.

1.7.1 Lifetime of actuators

The lifetime of an electric actuator (EA) is at least 6 years.

EA used for closing mode (closing valves) comply with the requirements for at least **15,000 working cycles** (cycle C – O – C: for part-turn EA)

EA used for regulating/modulating operation (control valves) comply with the below stated numbers of **operating hours** at the total number of 1 million start-ups:

Switching frequency				
max. 1,200 [h ⁻¹]	1,000 [h ⁻¹]	500 [h ⁻¹]	250 [h ⁻¹]	125 [h ⁻¹]
Minimal lifetime expectancy – number of operating hours				
850	1,000	2,000	4,000	8,000

Time of **net operation** is min. 200 hours, max. 2,000 hours.

Lifetime at operating hours depends on loading and switching frequency.

Note : High switching frequency does not ensure better regulation. Setting of regulation parameters should be therefore made with the inevitably necessary switching frequency needed for the process in question.

1.8 Operation conditions

1.8.1 Product location and operation position

- Electric actuators may be installed and operated in enclosed locations of industrial facilities with no temperature and moisture regulation, protected from direct climatic effects (such as direct sunlight). Moreover, special “marine” versions may be used in waste water treatment applications, water management, selected chemical applications, tropical environments and coastal areas.
- Electric actuators must be placed with access to the manual control wheel, to the cover of control box, to control box, to cable glands.
- Installation and operation of actuators is possible in either position. Common position is the one with vertical position of exit part axis and control box above. Avoid to arrange the electric actuator under the armature if possible.

Warning:

Actuator installed on the open place must be protected against a direct climate effects by shelter.

In applications placed in an ambient of a relative moisture above 80%, in external ambient under shed, it is necessary to change the preset thermostat temperature +25°C to +70°C by a PC and program to prevent switching off the heating resistor.

1.8.2 Working environment

According to valid standard IEC 60 721-2-1, there are delivered these versions of electric actuators:

- 1) Version „**standard**“ for type climate temperate
- 2) Version „**tropical wet**“ for type climate tropical wet
- 3) Version „**cold**“ - for type climate cold
- 4) Version „**tropical dry and dry**“ for type climate tropical dry and dry
- 5) Version „**marine**“ for type climate marine
- 6) Version „**arctic**“ for type climate arctic.

In accordance with IEC 60 364-1, IEC 60 364-5-51 and IEC 60 364-5-55 within valid edition the EA have to resist external effects and operate reliably:

In the conditions of the following types of environment:

- warm mild to very hot dry with temperatures -25°C to +55°C AA 7*
- cold, warm mild to hot dry with temperatures -50°C to +40°C..... AA 8*
- cold to mild hot dry with temperatures in range -60°C až +40°C.....AA 1*+AA 5*
- with relative humidity 10÷100%, including condensation with maximum content 0,029kg of water in 1kg of dry air , with temperatures stated above..... AB 7*
- with relative humidity 15÷100%, including condensation with maximum content 0,036kg of water in 1kg of dry air , with temperatures stated above..... AB 8*
- with relative humidity 5 to 100 %, including the condensation of up to 0,025 kg water content per 1 kg of dry, at above stated temperatureAB 1*+AB 5*
- with elevation up to 2000 m, with barometric pressure range from 86 kPa up to 108 kPaAC 1*
- with exposure to intensive water jets (IPx6).....AD 6*
- with submersion – (product with enclosure IPx8)..... AD 8*
- with strong dustiness – with a possibility of influences of inflammable, non-conducted and non-explosive dust; the middle layer of dust; the dust drop more than 350 but not more than 1000 mg/m² per day (products with protection enclosure of IP 6x)..... AE 6*
- with atmospheric appearance of corrosive and spoiling materials (with high degree of corrosive aggressiveness of the atmosphere; the presence of the corrosive spoiling materials is significantAF 2*
- with occasional or casual appearance of corroding and polluting substances (occasional or casual
- with permanent exposure of big amount of corroding or contaminated chemical and salt fog in execution for sea environment, fog sewage water disposal plant and some chemical plant AF 4*
- with a possibility of influences of mechanical stress:
 - medium sinusoid vibrations with frequency in range from 10 up to 150 Hz, with shift amplitude of 0,15 mm for $f < f_p$ and acceleration amplitude 19,6 m/s² for $f > f_p$ (transition frequency f_p is from 57 up to 62Hz)AH 2*
 - medium impacts, shocks and vibrationsAG 2*
 - with serious danger of plants and mould growing.....AK 2*
 - with serious danger of animal occurrence (insects, birds, small animals).....AL 2*
- with detrimental influence of radiation:
 - of stray current with intensity of magnetic field (direct or alternate, of mains frequency) up to 400A.m⁻¹ AM2-2*
 - of sun radiation with intensity > 500 and ≤ 700W/m² AN 2*
- with effects of medium seismic activity with acceleration > 300 Gal ≤ 600 Gal AP 3*
- with direct endanger by stormAQ 3*
- with quick air movement and strong wind AR 3 , AS 3*
- stand on a conductive bottom) BC 3*

* Marking in accordance with IEC 60364-1, IEC 60 364-5-51 and IEC 60 364-5-55 within valid edition

1.8.3 Power supply and duty cycle

Power supply:

- electric motor 120 V AC, 220/230/240 V AC, 3x400/3x380/3x415 V AC resp. 24 V AC/DC $\pm 10\%$
- control binary inputs 24 V DC $\pm 10\%$
..... input control signal 0/4/12 to 20 mA, 4 to 12 mA resp. 20 to 0/4/12 mA, 12 to 4 mA,
..... or 0/2 to 10 V, resp. 10 to 0/2 V
- electronic positional transmitter (EPV) without power supply (passive) 18 up to 30 V DC $\pm 10\%$

Frequency of power supply 50/60** Hz $\pm 2\%$

** At frequency of 60 Hz operating time is reduced by 1.2 times.

Duty cycle (according to EN 60034-1 (IEC 60034-1) within valid edition):

EA UPR XPA are designed for **remote control**:

- short-time operation **S2-10 min**
- intermitted operation **S4-25%, 6 up to 90 cycles per hour**

EA UPR XPA designed for **automatic regulation** via analogue signals are designed for :

- intermitted operation S4-25% with min. number of starts according to the following table:

Rated torque ranges [Nm]	On-Off [cycles per hour ^{a)}	Inching [starts per hour ^{b)}	Modulating with reverse contactors [starts per hour ^{c)}
Up to 125	15	120	1200

a) One cycle consists of nominal 90° angular travel in both directions (i.e. 90° to open + 90° to close), based on an average load of at least 30 % of the rated torque with the ability to transmit 100 % of the rated torque for at least 5 % at each end of travel, with a cumulative operating time not exceeding 15 minutes in one hour.

b) One start consists of a movement of at least 1° in either direction, with a load of at least 30 % of the rated torque. The cyclic duration factor (i. e. the ratio between the running period and total period) shall be not less than 25 % (e.g. 1 s running and 3 s resting).

c) One start consists of a movement of at least 1° in either direction, with a load of at least 30 % of the rated torque

Note: The operation modes consist of the loading type, load factor and connection/switching frequency.

Warning: Non-compliance with operating mode may result in inactivation of the EA as a result of failure of the integrated thermal fuse (protection) of the electric motor.

1.9 Packing, transport, storing and unpacking

Surfaces without surface treatment are treated by conservation preparation MOGUL LV 2-3 before packaging .

Conservation is not necessary if the following storage conditions are complied with:

- Storage temperature: -10 to +50 °C
- Relative air humidity max.80 %
- Electric actuators and their accessories must be stored in dry, well ventilated covered spaces, protected against impurities, dust, soil humidity (by placement to racks, or on pallets), chemicals and foreign interventions
- There shall be no corrosive gases present in the storage areas.

The of EA are delivered in solid packages guaranteeing resistance in accordance with EN/IEC 60 654.

Package is a box. Products in boxes is possible to load on the pallets (pallet is returnable). On the outer side of the package is stated:

- manufacturer label,
- name and type of product,
- number of pieces,
- other data – notices and stickers.

The forwarder is obliged to secure packed products, loaded on transportation means, against self-motion; if open transportation means are used, to secure their protection against atmospheric precipitations and splashing water. Displacement and securing of products in transportation means must provide their stable position, exclude the possibility of their inter-collision and their collision with the vehicle walls.

Transportation can be executed by heatless and non hermetic spaces of transportation vehicles with influences within the range:

- temperature: -25°C up to $+70^{\circ}\text{C}$ (a strange version -50°C up to $+45^{\circ}\text{C}$)
- humidity: 5 up to 100 %, with max. water content 0.029 kg/kg of dry air
- barometric pressure 86 up to 108 kPa

After receiving EA check whether during transport or storage the actuator was not damaged. Compare also whether the parameters on their nameplates are in accordance with accompanying documentation or the Contract. If any discrepancy or fault occur inform immediately your supplier.

If the actuators and accessories are not immediately installed, they have to be stored in dry, well-ventilated sheltered rooms, protected against dirt, dust, soil humidity (with placing onto shelves or onto pallets), chemical impacts and encroachment, at ambient temperature from -10°C up to $+50^{\circ}\text{C}$ and relative humidity max. 80 %, in special version at temperature -50°C do $+40^{\circ}\text{C}$.

- **It is forbidden to store EA outside or in areas not prevented against direct impact of climate.**
- Strains of the surface finishing should be promptly removed if any – it can prevent the product against corrosion damages.
- While storing more than one year it is necessary to check lubrication filling before the actuator is put into operation.
- The EA installed but not operated are to be protected the same way as when storing (e.g. with a wrapping).
- After it is mounted onto a valve in free and wet areas or in areas where temperature is changing it is necessary to connect the space heater – to prevent the actuator against corrosion resulted from water condensed in the control part.
- Remove odd conservation grease as late as before putting into operation.

1.10 Assessment of the product and packaging and removal of contamination

The product and its package are made of recycling materials. Do not throw the single parts of the package and of the product after their life but sort them according to instructions in corresponding executives or regulations of environment protection, and allow their recycling.

The product and its packing are not a source of any environment pollution or contamination and do not contain any dangerous waste.

2. Description, function and specifications

2.1 Description and function

The **UPR XPA** electric actuator is controlled by 24 V DC voltage fed to the electric actuator's terminals according to the wiring diagram, resp. by 0/4/12 up to 20 mA, 4 up to 12 mA (0/2 up to 10 V) (input control signal and provides for moving the output part of the EA automatically to a position corresponding to the value of the input signal) and other functions as well.

The electric actuator consists of these main parts (**Fig. 1, 1A**):

The electric actuator is driven by an **electric motor (1)** supplied (single-phase motor) from the **source board (3)** (single-phase motor) and **control unit (2)** of the DMS 3 electronics.

Position of output element of EA and torque is scanned by **contactless absolute sensor**. Depending on the version, the DMS3 electronic circuit board may include an **electronic position transmitter (EPV)** without power supply (passive) with output signal 4 to 20 mA.

Space heater (5) is placed at the control board.

In case of power cut or damage of switches the actuator can be controlled manually according to instructions stated in chapter 5.1 Service.

Basic modules of DMS3 electronic control system for UPR XPA:

Control unit (2) – main part of system DMS3 – it contains microprocessor, 6 signal LED and 4 buttons for simple adjustment and control of EA, connectors for connection of scanner and sourcing board and communication connector (connection to PC for adjustment and diagnostic), 2 free programmable relays R1 and R2, 1 relay READY and terminals for electric connection.

Sourcing board (3) – secures power supply of electronic and provides an output voltage of 24 V DC, 40 mA for the user, it contains user terminal board, switching circuits, connector for connection with control unit.

Position scanning unit (4) – secures contactless magnetic position scanning of output element.

Torque reading unit (6) – provides contactless magnetic torque reading.

LED display (7) – shows instant position of EA output member and reports and displays potential errors, which would occur when EA is operated. Signalling motion and failure of the EA is also indicated by LEDs diode. LED display is used only pro type of construction EA without local control.

Manual control: made up by a handwheel with a worm gearing.

Other accessories – as optional accessories:

- **3 additional relays** module RE3, RE4, RE5 (8).

- **local electric control module** equipped with 2-line LCD display (fig. 15).

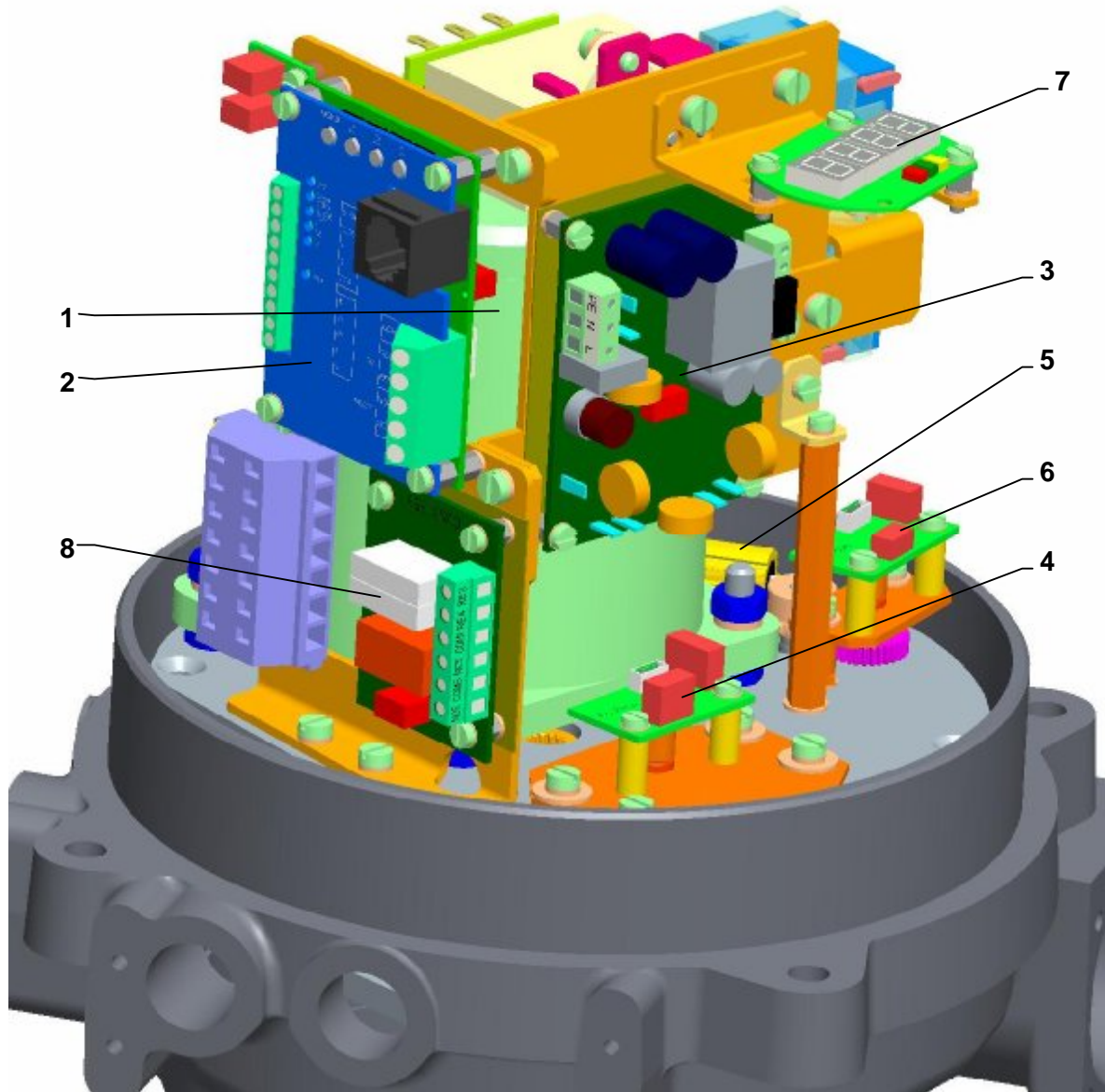

Fig. 1-UPR 1PA

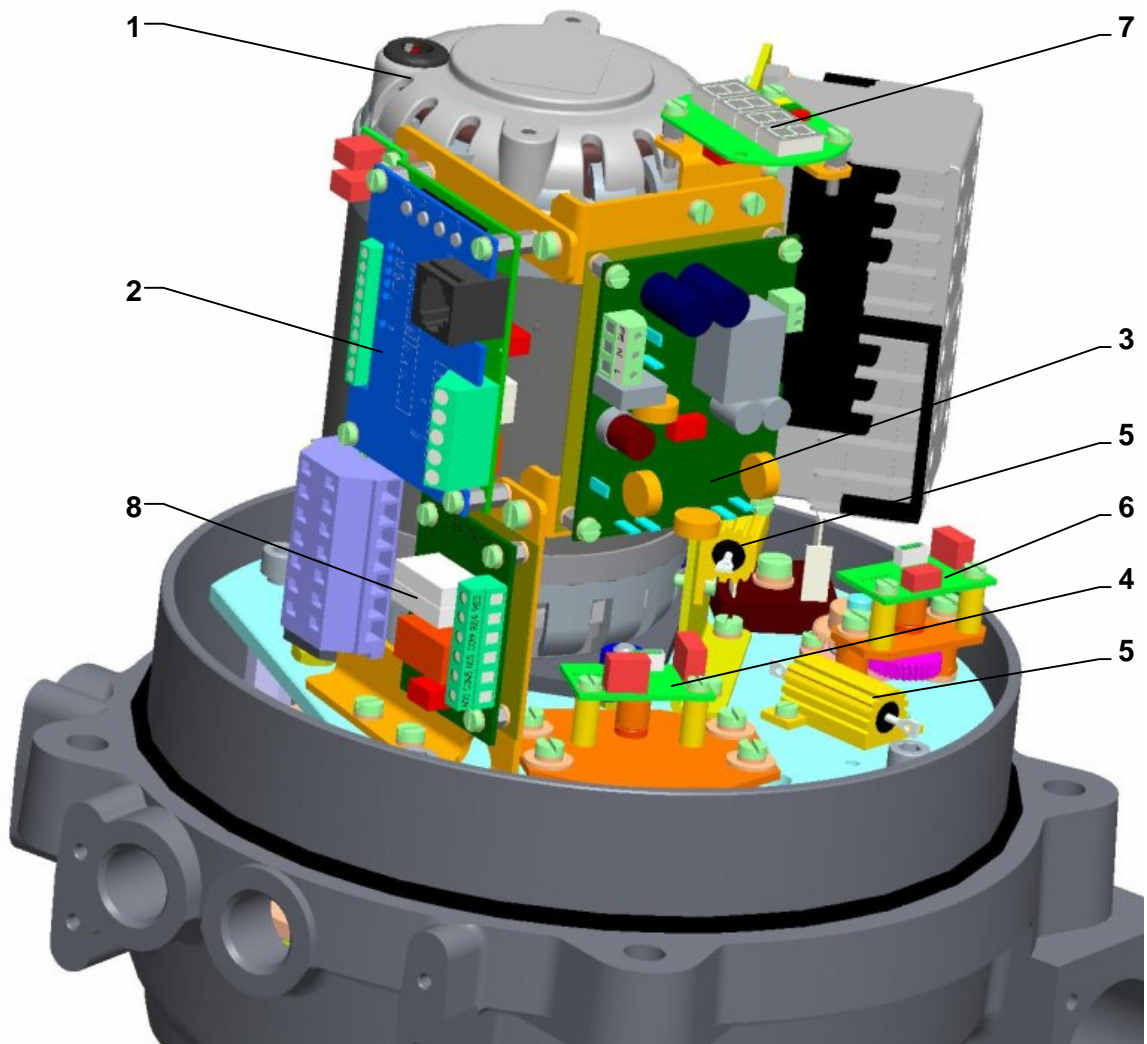

Fig. 1A-UPR 2PA-UPR 2.5PA

2.2 Basic specifications

Basic EA specifications:

are given in Table 1.

Table 1: Basic EA Specifications

Type/ type number	Operating speed ±10 %		Operating stroke	Max. load torque (ON – OFF duty)	Max. load torque - (Modulating duty)	Switching-off torque ±10 [%]	Weight	Electric motor						
								Supply voltage nominal voltage	Nominal		Current		Capacitor capacity	
									Power	Revolutions	nominal	starting ±20 %		[μF/V AC]
	[s/90°]		[°]	[Nm]	[Nm]	[Nm]	[kg]	[V]	[W]	[1/min]	[A]	[μF/V AC]		
	50Hz	60Hz												
1	2	3	4	5	6	7	8	9	10	11	12	13	14	
UPR 1PA type number 381	5		4 - 80	27	-	45	14 - 15	Single-phase	230 (220)	40	1300	0,53	1	5/400
	10			30	20	50								
	20			54	36	90								
	40			60	40	100								
	80			90	60	150								
	10			100	70	170								
	20			27	-	45								
	40			30	20	50								
	80			54	36	90								
	10			60	40	100								
	20			90	60	150								
	40			100	70	170								
	80			27	-	45								
	4			30	20	50								
	8			54	36	90								
	17			60	40	100								
	34			90	60	150								
	66			100	70	170								
	8			27	-	45								
	17			30	20	50								
	34			54	36	90								
	66			60	40	100								
	34			90	60	150								
	66			100	70	170								
	5	4		27	-	45								
	10	8		30	20	50								
	20	17		54	36	90								
	40	34		60	40	100								
	80	66		90	60	150								
	10	8		100	70	170								
	20	17		30	-	50								
	40	34		30	20	50								
	80	66		30	20	50								
40	34	60	40	100										
80	66	60	40	100										
40	34	90	60	150										
80	66	90	60	150										
80	66	100	70	170										
5		30	-	50										
10		30	20	50										
20		60	40	100										
40		60	40	100										
80		90	60	150										
10		100	70	170										
20														
40														
80														
40														
80														
80														
80														

Type/ type number	Operating speed ±10 %		Operating stroke	Max. load torque (ON – OFF duty)	Max. load torque - (Modulating duty)	Switching-off torque ±10 [%]	Weight	Electric motor							
								Supply voltage nominal voltage	Nom. power	Nom. revolutions	Current		Capacitor capacity		
											nominal	starting ±20 %			
	[s/90°]		[°]	[Nm]	[Nm]	[Nm]	[kg]	[V]	[W]	[1/min]	[A]		[µF/V AC]		
	50Hz	60Hz													
1	2	3	4	5	6	7	8	9	10	11	12	13	14	15	
UPR 2PA type number 382	5		4 - 100	72	50	120	20 - 24	Single-phase	230 (220)	120	2600	1,0	1,9	8/450	
	10			100	70	170				60	2750	0,7	1,35	7/400	
	20			110	72	180					20	1350	0,39	0,7	7/400
	40			180	120	300				120 (110) 60Hz		120	3100	2,0	3,8
	80			72	50	120			70		3380	1,1	2	7/400	
	5	7		100	70	170					25	1680	0,71	1,35	20/300
	10	8		110	72	180			Three-phase			3x400 (3x380)	180	2650	0,6
	20	17		180	120	300				90	2740		0,35	1,3	-
	40	34		72	50	120		Single-phase			230 (220)	120	2600	1,0	1,9
	80	66		100	70	170				60		2750	0,7	1,35	7/400
	5			110	72	180			120 (110) 60Hz		120	3100	2,0	3,8	8/450
	10			180	120	300				70	3380	0,71	2	16/250	
	20			72	50	120		Three-phase	3x400 (3x380)		180	2650	0,6	2,4	-
	40			110	72	180				90	2740	0,35	1,3	-	
	80			150	100	250			Single-phase		230 (220)	120	2600	1,0	1,9
	5			180	120	300				60		2750	0,7	1,35	7/400
10		72	50	120	120 (110) 60Hz	120	3100	2,0			3,8	8/450			
20		110	72	180		70	3380	0,71		2	16/250				
40		180	120	300	Three-phase		3x400 (3x380)	180	2650	0,6	2,4	-			
80		72	50	120		90		2740	0,35	1,3	-				
10		150	100	250			Single-phase	230 (220)	120	2600	1,0	1,9	8/450		
20		180	120	300		60			2750	0,7	1,35	7/400			
40		72	50	120	120 (110) 60Hz			120	3100	2,0	3,8	8/450			
80		110	72	180		70		3380	0,71	2	16/250				
10		150	100	250	Three-phase		3x400 (3x380)	180	2650	0,6	2,4	-			
20		180	120	300		90		2740	0,35	1,3	-				
40		72	50	120			Single-phase	230 (220)	120	2600	1,0	1,9	8/450		
80		110	72	180		60			2750	0,7	1,35	7/400			
10		150	100	250	120 (110) 60Hz			120	3100	2,0	3,8	8/450			
20		180	120	300		70		3380	0,71	2	16/250				
40		72	50	120	Three-phase		3x400 (3x380) (3x415)	180	2650	0,6	2,4	-			
80		110	72	180		90		2740	0,35	1,3	-				

1) The total current of EA is the sum of the electronics current (0.15 A) and the electric motor current according to the EA version

Other specifications:

Protection enclosure of EA:IP 66/IP 68 (EN/IEC 60 529)

According to definition for EA, enclosure IP68 fulfills following requirements:

-water column max. 10m

-time of continuous submersion in water max. 96 hours

Mechanical ruggedness:

sinusoid vibrations see Chapter 1.8.2

resistance by drops 300 drops with acceleration of 5 m.s^{-2}

Self-locking: the EA is self-locked

Electric motor protection:with thermal switch

EA braking:by roller bief

Electric control:

remote control - movement of output part of the electric actuator is controlled :

- by binary inputs 24 V DC, or

- by unified input signal 0/4/12 up to 20mA, 4 up to 12mA resp. 20 up to 0/4/12 mA, 12 up to 4mA or 0/2 up to 10V, resp. 10 up to 0/2 V according to version.

Power supply of electronics:

- Power supply ZS is used for single phase and three phase versions and feeds the electronic modules built in EA.
- It provides the 24V DC, 40 mA output voltage.

Power sources contain a protective fuse with parameters according to chapter 2.2.2. Electric connection.

Position scanning:

- contactless absolute magnetic.

End positions adjustment:

End position relays are adjusted with accuracy to specific operating angle $\pm 2^\circ$.

It is possible to set up (with buttons situated on the control unit, resp. with buttons situated on the local control, resp. program after connecting the EA with PC) the shutting off in end positions as follows:

- Z = Torque + O = Torque

- Z = Torque + O = Position

- Z = Position + O = Torque

- Z = Position + O = Position

Notes:

C = Torque - shutting off at end limit - torque „Closed“

O = Torque - shutting off at end limit - torque „Opened“

C = Position - shutting off at end limit - position „Closed“

O = Position - shutting off at end limit - position „Opened“

Factory's setup of shutting off in end positions is described in the chapter "Adjusting of actuator".

Torque scanning: - contactless absolute magnetic.

Disengaging torque adjusting:

Disengaging torque is factory adjusting to a maximum value with the $\pm 10\%$ tolerance shown on the nameplate of the appropriate EA.

The user is allowed to modify the switching-off torque value within the range 50 - 100%, stepped by 10%.

Torque blocking:

The switching-off from torque can be blocked within a certain range of the stroke starting from a stroke end position (max..5%), for time agreed on, in range of 0 to 20 sec..

Output relay :

- 3x relays (standard) (**READY, R1, R2**) max. 250 V AC/1 A/cos phi=1; max. 30 V DC/2A

- 3x additional relays (options) (**RE3, RE4, RE5**) max. 250 V AC/1 A/cos phi=1; max. 30 V DC/2A

- relays **READY, R1, R2, RE3, RE4 and RE5** are free programmable (their function can be changed with buttons on the control unit, with buttons on the electric local control, or through a PC with the program).

READY relay: - programme selections option – error indication, error or warning, error or not remote, error or warning or not remote. READY relay factory set is shown in the “Adjusting of actuator” Chapter.

R1 and R2, RE3, RE4 and RE5 relay: - programme selections option – disabled, Position O (position open), Position C (position close), Torque O (torque open), Torque C (torque close), Torque O or Torque C, Torque O or Position O, Torque C or Position C, opens, closes, movement, movement – flasher, to position, from position, warning, control – remote, control – local, (not valid for EA without local control), control OFF.

RE3, RE4, RE5 relays are independent. Factory setting up of the individual relays is shown in the “Adjusting of actuator” Chapter.

Transmitter (output signal)

Electronic position transmitter (EPV) passive (for single phase versions)- 2-wire connection

(without inbuilt power supply)

Current signal.....	4 ÷ 20, resp. 20 ÷ 4 mA (DC)
Voltage at connection of EPV passive.....	18 up to 30 V DC
Load resistance	max. $R_L = 500 \Omega$
Tolerance of value of output signal of electronic transmitter in end positions:	$\pm 0,5 \%^{1)}$
Tolerance of linearity of transmitter	$\pm 1 [\%]^{1)}$
Hysteresis of transmitter	max. 1 $[\%]^{1)}$

1) from nominal value of transmitter referred to output values

Galvanic separation..... output signal is galvanically separated from input control signal

Program possibilities of output signal : 4 ÷ 20 mA, 20 ÷ 4 mA. Factory’s setup of output signal is described in the chapter “Adjusting of actuator”.

Electronic controller (N) – actuation by input control signal

Input control signals - analogue:	0 - 20 mA (0 – 10 V according to version)
.....	4 - 20 mA (2 – 10 V according to version)
.....	12 - 20 mA
.....	4 - 12 mA
.....	20 - 0 mA (10 – 0 V according to version)
.....	20 - 4 mA (10 – 2 V according to version)
.....	20 - 12 mA
.....	12 - 4 mA
Input resistor for signal 0/4/12 up to 20 mA. 4 up to 12 mA	$R_{in} = 120 \Omega$
Input resistor for signal 0/2 up to 10 V	$R_{in} = 30 \text{ k}\Omega$
Tolerance of controller’s linearity:	0,5 %
Dead of controller:	program adjustable within 1 - 10%

Factory’s setup of input signal is described in the chapter “Adjusting of actuator”.

Control by binary inputs 24 V DC:

- by feeding of 24 V DC to terminals **CLOSE** and **OPEN**.

Programming possibilities of binary inputs I1 and I2 (change is possible only through the programme of PC or using buttons local control)

- for the input **I1** : DISABLED; ESD; DBL (local releasing - not valid for EA without local control), STOP
 - for the input **I2** : DISABLED, ESD; DBL (local releasing - not valid for EA without local control), 2P (the EA can undergo control for the opening direction or closing with the controller ON and I2 input activated with 24 V DC voltage supplied to the terminals to OPEN or CLOSE).

Factory’s setup is described in the chapter “Adjusting of actuator”.

Programmable FAILURE REACTION : OPEN, CLOSE, STOP, SAFE POSITION

Factory’s setup is described in the chapter “Adjusting of actuator”.

Adjustable elements of electronics:

The EA is possible to adjust with or resetting to different parameters operating the control unit buttons, or with buttons on the local control (according to version), or once it is connected to the PC using the programme and the communication cable connected to the EA control unit communication connector and the EA cover removed.

Space heater (E1)

Space heater - supply voltage:corresponding with motor supply voltage (max. 250 V AC)
 Space heater power output: UPR 1PA cca 10 W/55°C
 UPR 2PA, UPR 2.4PA, UPR 2.5PA cca 40 W/55°C

. Electronic board provides switching of heating element. It is possible to change switching temperatures of the switch from -40°C to $+70^{\circ}\text{C}$ with help of PC and particular software. Factory's setup for shut down of heating element (thermostat) is $+25^{\circ}\text{C}$.

Manual control:

- with manual handle on the upper cover of the EA. Turn the manual handle clockwise to move the output shaft of the EA in the direction "Z – closed".

Output part backlash: max. 1° (at 5 % of maximum switching torque load)

Grease: see chapter Maintenance - extent and periodicity.

2.2.1 Mechanical Connection

- flange ISO 5211.

Main and connecting dimensions are given in the **dimensional drawings**.

2.2.2 Electric connection**To the terminal board (X, X1, X2, X3):**

- 2 terminals (N, L) on the sourcing board for version 24 V AC/DC, with intersection of connection wire $0,05 - 1,5 \text{ mm}^2$ for solid wire and for flexible wire.
- 3 terminals (PE, N, L) on the sourcing board with intersection of connection wire $0,05 - 1,5 \text{ mm}^2$ for solid wire and for flexible wire. Max. terminal screw tightening torque $0,5 \text{ N.m}$.
- 3 terminals (2(L1), 3(L2), 4(L3) – for version UPR 1PA with 3- phase electric motor)) with intersection of connection wire max. $0,08-2,5 \text{ mm}^2$ - screw-less terminal
- 5 terminals (PE, N, 2(L1), 3(L2), 4(L3) – for version UPR 1PA with 3- phase electric motor)) with intersection of connection wire max. $0,08-2,5 \text{ mm}^2$ - screw-less terminal
- 2 terminals (5,6 - for version with wired 3- phase electric motor) with intersection of connection wire max. $0,08-2,5 \text{ mm}^2$ - screw-less terminal
- 2 terminals (OP, CL - for version with wired 3- phase electric motor) with intersection of connection wire max. $0,08-2,5 \text{ mm}^2$ - screw-less terminal
- 2 terminals (0 V, + 24V) - with intersection of connection wire max. $1,5 \text{ mm}^2$. Max. terminal screw tightening torque $0,285 \text{ N.m}$.
- 5 terminals (READY, R1, R2) with intersection of connection wire $0,05 - 1,5 \text{ mm}^2$ for solid wire and for flexible wire. Max. terminal screw tightening torque $0,5 \text{ N.m}$.
- 10 terminals (COM, CLOSE, OPEN, I1, I2, +IN,-IN,SH,+L,-L) with intersection of connection wire $0,05 - 1 \text{ mm}^2$ for solid wire and for flexible wire. Max. terminal screw tightening torque $0,19 \text{ N.m}$.
- 6 terminals (COM1, RE3, RE4, COM5, NO5, NC5) - for module additional relays with intersection of connection wire $0,05 - 1,5 \text{ mm}^2$ for solid wire and for flexible wire. Max. terminal screw tightening torque $0,5 \text{ N.m}$.

Wire stripping length of the wires for screwless terminals is from 8 to 9mm.

Cable glands :

- for version without local control

3 cable glands - M20 - cable diameter 8 to 14,5 mm

- for version with local control

2 cable glands - M20 - cable diameter 8 to 14,5 mm.

Protective terminal:

Upon start-up in operation - at equipment installation:

- for safe use of the actuator it is necessary to connect the outside and inside grounding terminal. The position of the outside and inside grounding terminal can be seen in Fig. 1C and Fig. 1D and fig.1F.

HP3 insulated eyelet crimping pliers should be used to crimp wire to the outside grounding terminal (fy CEMBRE)..

Outside and inside, mutually interconnected and identified with a **protective grounding symbol**.

There must be power switch or motor circuit breaker included to the power supply which must be placed as close as possible to the device, easily accessible to the operator and marked as an disconnecting device of actuator.

The electrical connection is made according to the wiring diagrams inserted or. glued to the top cover of the EA.

Product protection

We recommend to use fuses for protection of product.

Fuses:

Actuator power supply board for version 24V AC/DC is installed with power supply fuse (F3). Location of the fuse on the power supply board can be seen in Fig.1H.

Actuator power supply board for version with single-phase or three-phase electric motor is installed with power supply fuse (F3). Location of the fuse on the power supply board can be seen in Fig.1D.

ES equipped with a contactless switching module (SSR) are additionally protected by fuses (F4-1 and F4-2) on the holder Fig.1G.

Type	Order code	Voltage	Frequency (Hz)	Electric motor Power / Power input (W)	Max. current EA (A)	Fuse values F3	Fuse value only for version with SSR) F4-1 F4-2 (6,3x32mm		
UPR 1PA 381	381.X- AXXXX/YY	24 VDC	-	53/76	3,0	T 3,15 A / 250 V	-		
		24 VAC	50		4,7				
			60						
	381.X- 0XXXX/YY	230 VAC	50	40/90	0,8	F 2,5 A / 250 V	-		
	381.X- LXXXX/YY	220 VAC							
	381.X- TXXXX/YY	120 VAC		60	40/90			0,94	
381.X- BXXXX/YY	110 VAC	60							
381.X- 2XXXX/YY	3x400 VAC	50	40/110	0,42	F 2,5 A / 250 V	-			
381.X- NXXXX/YY	3x380 VAC								
UPR 2PA 382	382.X- 0XXXX/YY	230 VAC	50	20/75	0,57	F 2,5 A / 250 V	-		
	382.X- LXXXX/YY	220 VAC		60/120	1,06				
	382.X- 0XXXX/YY	230 VAC	60					70/125	1,5
	382.X- LXXXX/YY	220 VAC		60	70/125				
	382.X- TXXXX/YY	120 VAC	90/150					0,68	F 2,5 A / 250 V
	382.X- BXXXX/YY	110 VAC							
	382.X- 2XXXX/YY	3x400 VAC	50	90/150	0,68	F 2,5 A / 250 V	-		
	382.X- EXXXX/YY	3x415 VAC					FF 3,15A/500V		
	382.X- NXXXX/YY	3x380 VAC	50	120/228	1,6	F 3,15 A / 250 V	-		
	382.X- FXXXX/YY	3x380 VAC						60	
	382.X- 0XXXX/YY	230 VAC	60	120/228	2,5				
	382.X- LXXXX/YY	220 VAC						50	180/300
	382.X- TXXXX/YY	120 VAC	3x400 VAC	180/300	0,97				
	382.X- BXXXX/YY	110 VAC						3x415 VAC	180/300
	382.X- 2XXXX/YY	3x400 VAC	3x380 VAC	180/300	0,97	F 2,5 A / 250 V	-		
	382.X- EXXXX/YY	3x415 VAC					3x380 VAC	180/300	0,97
	382.X- NXXXX/YY	3x380 VAC	3x380 VAC	180/300	0,97	F 2,5 A / 250 V			
	382.X- FXXXX/YY	3x380 VAC					3x380 VAC	180/300	0,97

Attention: Thermic resistance incoming wires must be minimum +90°C.

Electric connection: - according to the wiring diagram stuck into the case of the EA.



Fig.1C

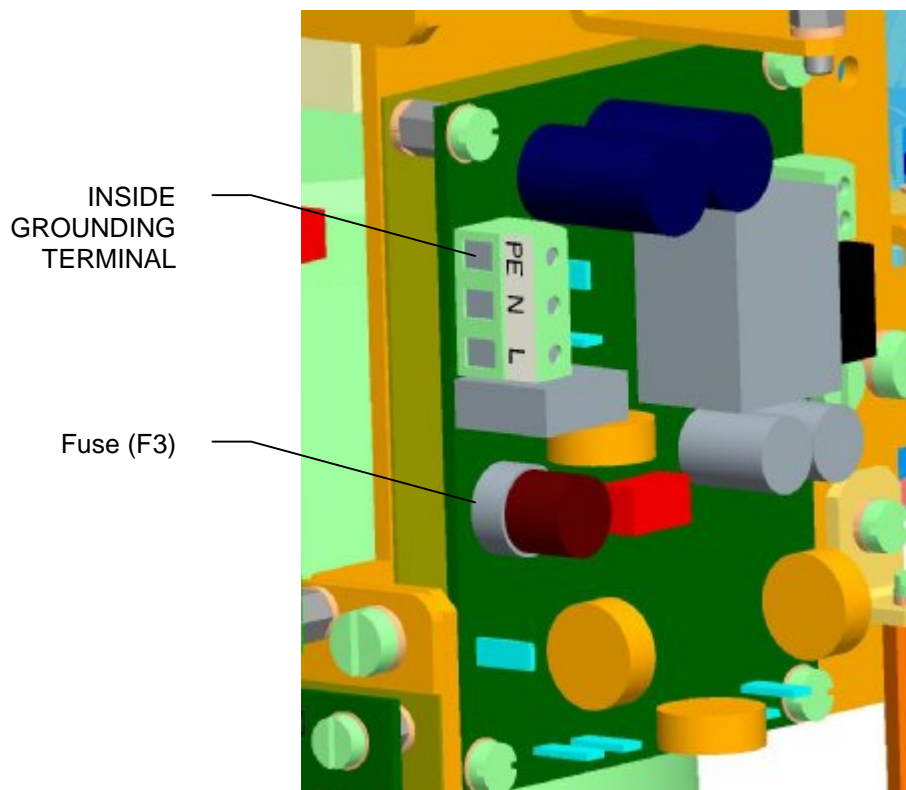

Fig.1D

INTERNAL PROTECTION TERMINAL FOR EA UPR XPA THREE PHASE VERSION



Fig.1F

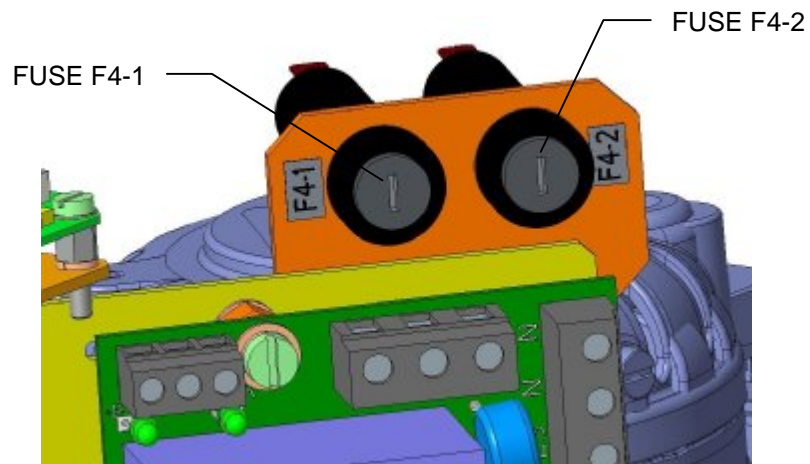

Fig.1G

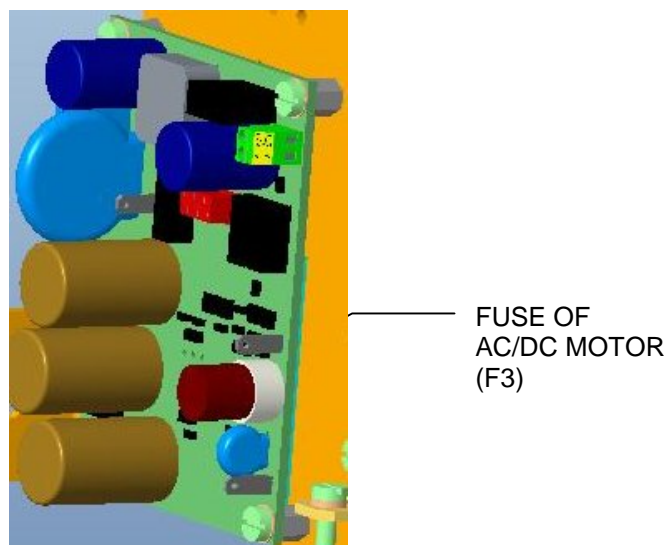

Fig.1H

3. Installation and dismantling of actuator



Abide by safety measures!

Note:

Check again if placement of EA reply to chapter "Operation conditions". In case that operation conditions are different from recommended, consultation with producer is needed.

Before starting of mounting the EA onto the valve:

- Check again whether the EA was not damaged during storing.
- Check whether the adjusted operation stroke and connecting dimensions of the actuator (see the nameplate) are in compliance with the valve parameters.
- In case of inconsonance, perform adjusting according to the part "Adjustment".

3.1 Installation

EA is by the producer adjusted to parameters according to the nameplate.
Before installation put the handwheel on.

3.1.1 Mechanical flange connection

- Defat the abutting areas of the connecting flange of the EA valve or the gear carefully;
- Lubricate the output shaft of the valve/gear with a grease not containing any acids;
- Set the EA to the limit position "closed", set the valve to the same position;
- Put the EA onto the valve with the output shaft reliably stalled in the valve coupling/gear;
- **Attention! Do not adjust EA on an armature forcibly because of damage of the gear!**
- Use the handwheel to turn the EA to fit the openings in the EA and valve flanges if needed;
- Check whether the connecting flange abuts with the valve/gear;
- Fix the flange with four screws (with mechanical strength min 8G) fixed the way the actuator can Be moved. Tighten the screws equally in cross;
- At the end check the correctness of the fixture with the valve with rotating the handwheel.

3.1.2 Electric connection and checking of function

Follow up with connecting the EA with mains or master system.



1. Follow instructions in the part "Requirements for specialized...!"

2. While laying electrical line abide by the instructions for heavy current installations. Power supply cables must be of the type approved. Minimum thermal resistance of power supply cables and wires must be +90°C.

3. Cables to terminal boards or connectors lead through cable glands.

4. Before initiation ES into operation internal and external protection terminals are needed to be connected.

5. While fixing the cable it is needed to count with allowed bend radius to avoid damaging or deformation of the sealing element of the cable gland. The leads are to be fixed with the solid construction at most 150 mm from the cable glands.

6. Wires of input control signals to controller and output signals it is necessary to lead them separately with thrust wires or it is necessary to use shielded wires.

7. Reversation of the EA is sure, if the period between switching-off and switching-on of power supply for the reversed movement of the output part is minimally 50 ms.

8. The EA are delivered with cable glands, which in case of tight putting on the leads assure protection enclosure up to IP 68.

9. The face areas of the control part cover have to be before re-mounting clean, coated with grease without any acid (e.g. vaseline) and sealing not damaged to avoid joint corrosion.

Connecting with the master system:

EA can be controlled by: - analogue signals through the built-in position controller
 - binary inputs 24 V DC

EA is connected according to wiring diagram under the cover of EA.



In version UPR XPA it is necessary to do calibration in operation according by enclosure assure the optimal function.



The face areas of the control part cover have to be before re-mounting clean, coated with grease without any acid (e.g. vaseline) and sealing not damaged to avoid joint corrosion. Abide by instructions of valve producers, whether switching-off in end positions is to be realised with position or torque switches.

NOTES:

1. To connect the input control signals and output signals is needed to use shielded wires with steel wire braid (Galvanised Steel Wire Braid GSWB Ξ), for example cable type "Bruflex[®] HSLCH", 4x0, 5 (company Bruns Kabel).
2. Electrical installation of the actuator and its connection to switching, protection and safety devices can be performed by a person with competent qualification only. All the respective standards and electric wiring diagrams cited in the Manual must be kept.
3. The control of all the terminals must be realized after electrical connection of inlet cables. Junction terminals must not be stressed by the connected cables neither by traction nor by bending. Performance of the following measure is recommended in case alluminium wires are used: Immediately before the installation of the aluminium wire the oxidized layer on the wire must be removed and to prevent a new oxidation of the junction a neutral vaseline shall be applied.

Important note:

- 1) Please avoid (in a standard way) any electric connection of the actuator to the electric net during adjusting, repair and maintenance activities. Keeping this you avoid the potential injury caused by electric current or rotation of the actuator.

3.2 Dismantling**Attention!**

***Before disassembly is necessary to disconnect electric supply of electric actuator!
 Secure by prescribed way protection against connection of EA to the network and thus potential electrical accident!***

- Disconnect the EA from mains.
- Disconnect the leads from the EA terminal boards and loosen the cables from cable glands. Pull out the connectors in case of the connector version.
- Loosen the fixing screws of the EA flange and coupling screws and disconnect the EA from the valve.
- While sending the EA to be repaired put it into a package solid enough to avoid damages of the EA during transportation.



Taking the EA to pieces for repair purposes is allowed only by professionally qualified persons trained in the production plant or by a contracted service centre!

4. Adjusting of actuator



Attention! See the Chapter 1.3 Instructions for staff training
Keep safety regulations! Follow the prescribed procedure to assure that the EA is not connected to mains when live not to cause any injury by electrical current!

EA are delivered adjusted onto parameters according to nameplate from Production plant.

Adjustment is made onto mechanical and electrical connected actuator. This chapter describes how to set up the EA to parameter values within a range applicable for the software. Location of adjustable parts of control board is on **Fig. 6**.

Adjusting is possible:

- by operating the control unit buttons (see Fig. 6);
- by operating the local control panel buttons (see Fig. 15) – only for the EA s equipped with local control;
- through the programme once the EA is connected to the PC using the communication cable.

For the specific adjustment procedure or individual parameters reset see individual appendixes **74 1053 02, 74 1076 02**.

For facilitating the simple setting of required operation parameters, the control unit is equipped with :

- four setting buttons: **MENU, P, O, C**
- six signal lamps according (LED diode) to **Fig. 6**.

Status indication by means of LED diodes:

LED ERROR (red) – blinks red in case of failure eventually lights in the parameter setting mode

LED OPEN / MENU (green) – in the ON/OFF mode it lights with a control action for the **opening** direction eventually blinks with accessing the MENU mode

LED CLOSE / PAR (red) – in the ON/OFF mode it lights with a control action for the closing direction eventually blinks besides the chosen parameter in the menu and lights up at writing the parameter into the memory

- **LED I1 / SEL** (yellow) – permanent lights with active input I1, or flash in the mode of parameters set up.

- **LED I2** (yellow) – permanent lights with active input I2

- **LED POWER** (green) – it light on at leading the power supply.

Electronics - programme selections option

- **relay R1; R2** : disabled; open position, close position, torque-open, torque – close, torque open or torque close, torque open or position open, torque close or position close, open, close, movement, movement flasher, to position, from position, warning, remote control, local control, control shut off.

- **relay READY**: errors, errors or warnings, errors or no remote, errors or warnings or no remote.

- **output signál** (from EPV passive): 4 to 20 mA; 20 to 4 mA.

- **control (regulating)**: 2P, 3P, 3P/2P I2

- **input control signal** (N): 0/4/12 up to 20 mA, 4 up to 12 mA, resp. 0/2 up to 10 V.

- **input I1**: DISABLED, ESD, DBL (local releasing - not valid for EA without local control), STOP

- **input I2**: DISABLED, ESD, DBL (local releasing - not valid for EA without local control), 2P (with active controller - to enable program control 3P/2P I2 - enables control by binary inputs 24V DC with active input I2).

- **FAILURE REACTION**: OPEN, CLOSE, STOP, SAFE POSITION

The identical functions cannot be set on I1 & I2 inputs in addition to the OFF state (e.g., if the ESD) function is set on I1 input, it is not possible to select the ESD function on I2 input at the same time).

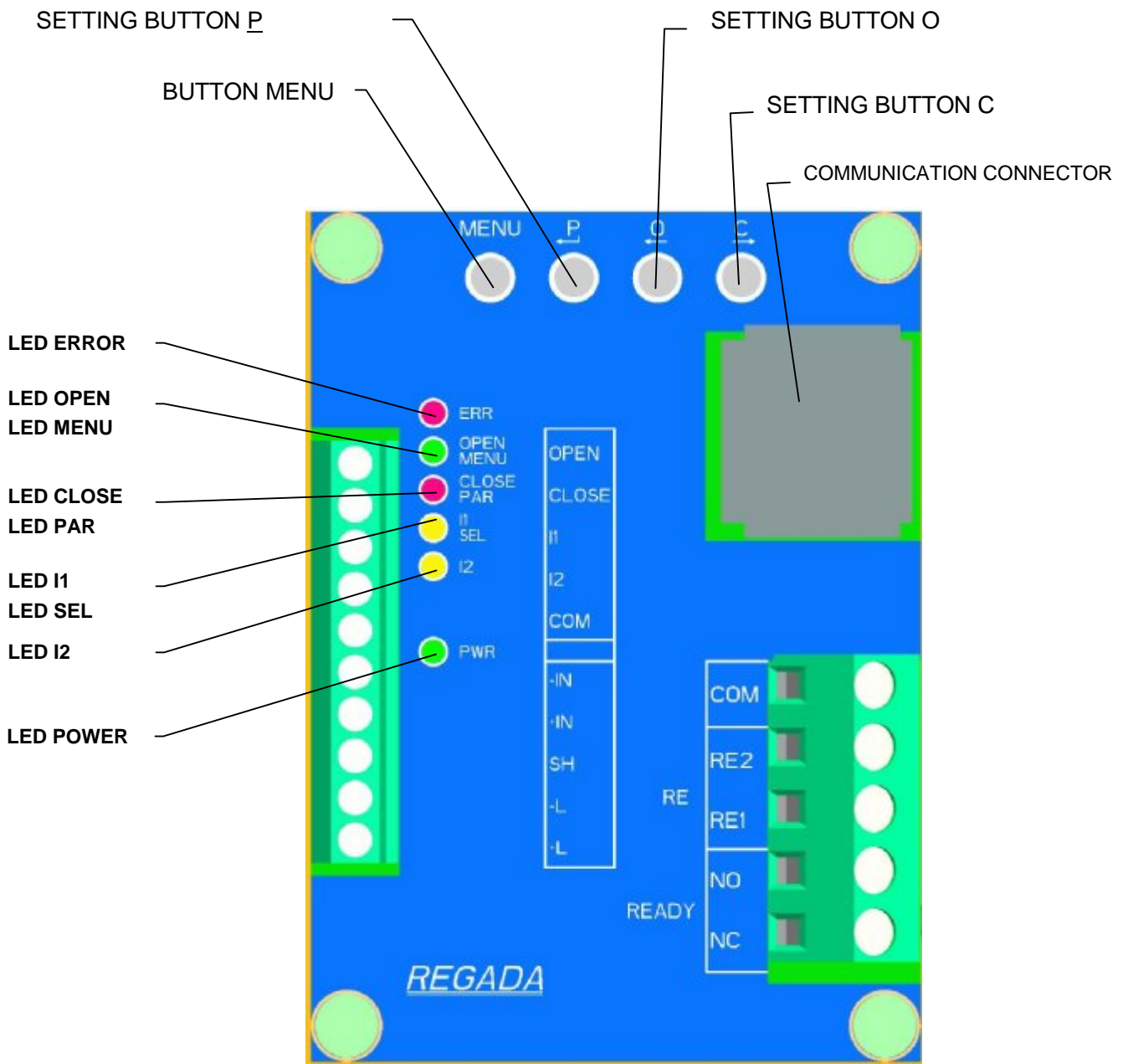

Fig. 6

4.1 EA control set-up options (regulating)

2P CONTROL

Setting-up: **2P** control + other functions, in addition to **STOP** on I1 terminal:

The EA moves either to the OPEN or CLOSE direction with **24V DC** voltage supplied to terminals **OPEN** or **CLOSE**. The EA stops if power supply is cut-off or the end position is reached.

2P PULSE CONTROL

Setting-up: **2P** control + **STOP** function on I1:

The EA moves either to the OPEN direction or closes with **24V DC** voltage pulse supplied on connectors **OPEN** or **CLOSE**. The EA stops – shutting off - once the 24V DC voltage is supplied on I1 connector (STOP) or the set end position is reached.

3P CONTROL (REGULATING)

Setting-up: 3P control + other functions, in addition to STOP on I1 and other ones in addition to 2P on I2 input.

The EA moves either to the OPEN or CLOSE direction with 0/4/12 up to 20 mA, 4 up to 12 mA (0/2 up to 10V) **input control signal** supplied on terminals **+IN, -IN**. The EA stops once the required position is reached (corresponding with the input control signal supplied) or the set end position is reached.

Note: The ES fails to stop in case that the STOP function is selected on I1 input with 3P control mode and 24V DC voltage supplied on I1 terminal.

3P/2P switched over to I2

Setting-up: **3P/2P** control switched over to **I2** (**2P** function is automatically selected for **I2** input function in selecting this control option) + other functions in addition to STOP on I1:

The EA moves either to the OPEN or CLOSE direction with 0/4/12 up to 20 mA, 4 up to 12 mA (0/2 up to 10V) **input control signal** supplied on terminals **+IN, -IN**. The EA stops once the required position is reached (corresponding with the input control signal supplied) or the set end position is reached.

The EA stops to respond to signal **0/4/12 to 20 mA, 4 to 12 mA (0/2 to 10 V)** input control signal and rests in case of **I2 active input** (with 24V DC constantly ON or OFF – as per I2 function set-up to ACTIVE – or supplied on I2 connector). The EA is allowed to move either to the **OPEN** or **CLOSE** direction with **24V DC** voltage supplied to terminals **OPEN** or **CLOSE**. The EA stops if power supply is cut-off or the end position is reached. The EA stops to respond to the input control signal and fixes its position once the supply voltage on I2 is OFF.

3P/2P switched over to I2 (PULSE 2P)

Setting-up: **3P/2P** control switched over to **I2** (**2P** function is automatically selected for **I2** input function in selecting this control option) + other functions in addition to **STOP** on I1:

The EA moves either to the OPEN or CLOSE direction with **input control signal** 0/4/12 up to 20 mA, 4 up to 12 mA (0/2 up to 10V) supplied on connectors **+IN, -IN**. The EA stops once the required position is reached (corresponding with the input control signal supplied) or the set end position is reached.

The EA stops to respond to **0/4/12 to 20 mA, 4 to 12 mA (0/2 to 10 V)** input control signal and rests in case of **I2 active input** (with 24V DC constantly ON or OFF – as per I2 function set-up to ACTIVE – or supplied on I2 terminal). The EA is allowed to move either to the OPEN or CLOSE direction with **24 V DC** voltage pulse supplied connectors **OPEN** or **CLOSE**. The EA stops once the 24V DC voltage is supplied on I1 terminal (STOP) or the set end position is reached.

The EA stops to respond to the input control signal and fixes its position once the supply voltage on I2 is OFF.

4.2 Procedure for setting individual parameters and the register of errors and warnings

- is given in the separate attachment 74 1053 02 resp. 74 1076 02 of these operating instructions. The factory default setting of individual programmes shown in Table 3 and Table 4, as long as otherwise specified by the customer:

Table 3

Factory default settings of individual parameters in version without local control; possibility to set-up by operating the control unit buttons.

For the individual parameters set-up see appendix 74 1053 02

MENU	NAME	FACTORY SETTING-UP	
1	TORQUE	100% of value shown on nameplate for OPEN & CLOSE direction.	
2	END LIMIT	<ul style="list-style-type: none"> - C = Position + O = Position - end position switching closed and open from position if valve type is not specified - C = Torque + O = Position - closed in end by thrust position and end position switching open from position for single-seat valves - C = Torque + O = Torque – switching in both end positions by thrust for double-seat valves 	
3	TORQUE BLOCKING	<ul style="list-style-type: none"> - 2 sec. blocking time - 5% blocking position for OPEN & CLOSE direction 	
4	RELAY READY	- errors (READY COM-NO relay contacts closed in error free conditions)	
5	RELAY 1...RE5	<ul style="list-style-type: none"> - position O for relay R1 - position C for relay R2 - from position 95% for relay RE3 - to position 5% for relay RE4 - disabled for RE5 relay 	
6	CPT (output signal)	4 to 20 mA	
7	REGULATION – (according to specification)	2P	3P
	ANALOG INPUT	-	4 to 20 mA (2 to 10 V)
8	DEAD ZONE	-	3 %
9	FAILURE REACTION	STOP	

Other parameters set-up is possible to change only by using the PC software

TITLE	FACTORY SETTING-UP
THERMOSTAT TEMPERATURE	25 °(space heater OFF temperature)
INTERNAL DEAD ZONE	2 % (only for 3P)
Safe position	0 %
FUNCTION I1	ESD
ACTIVE I1	high level
FUNCTION I2	DISABLED
ACTIVE I2	high level
THERMAL FUSE FAILURE	functionless with this EA type
THERMAL FUSE RESET	functionless with this EA type
CYCLE MODE	DISABLED
CYCLE RUNNING TIME	10 s
CYCLE PAUSE	50 s
CYCLE POSITION O1	0 %
CYCLE POSITION O2	100 %
CYCLE POSITION C1	0 %
CYCLE POSITION C2	100 %
O AND C TOLERANCE	1 %
CREATE BACKUP	START
RESTORE FROM BACKUP	START
RESTORE FACTORY SETUP	START
ACTIVE ERRORS	CLEAR

Table 4
Factory default settings of individual parameters in version with local control; possibility to set-up by operating the local control buttons. For the individual parameters set-up see appendix 74 1076 02.

MENU	NAME	FACTORY SETTING-UP	
1	JAZ/LANGUAGE	English (select language on LCD display)	
2	POSITION O	work angle range set as per EA specification	
3	POSITION C		
4	REG. CALIBR.	START	
5	END LIMIT	- C = Position + O = Position - end position switching closed and open from position	
6	TORQUE O	100% of value shown on nameplate	
7	TORQUE C	100% of value shown on nameplate	
8	BLOCK. TIME	2 s	
9	BLOCK. POS. O	5 %	
10	BLOCK. POS. C	5 %	
11	CPT (output signal)	4 to 20 mA	
12	REGULATION-(according to specification)	2P	3P
13	ANALOG. INPUT	-	4 to 20 mA
14	DEAD ZONE	-	3 %
15	INT. DEAD Z.	-	2 %
16	FAIL. REACT.	STOP	
17	SAFE POSIT.	0 %	
18	FUNCTION I1	ESD	
19	ACTIVE I1	high level	
20	FUNCTION I2	DISABLED	
21	ACTIVE I2	high level	
22	THERMO. FAIL. (THERMAL FUSE FAIL)	functionless with this EA type	
23	THERMO. RESET (THERMAL FUSE RESET)	functionless with this EA type	
24	RELAY READY	errors	
25	RELAY 1	Position O (POSITION OPEN)	
26	RELAY 1 POS.	0 %	
27	RELAY 2	Position C (POSITION CLOSE)	
28	RELAY 2 POS.	0 %	
29	RELAY 3	FROM POSITION	
30	RELAY 3 POS.	95 %	
31	RELAY 4	TO POSITION	
32	RELAY 4 POS.	5 %	
33	RELAY 5	DISABLED (OFF)	
34	RELAY 5 POS.	0 %	
35	CYCLE MODE	DISABLED	
36	CYCLE RUN. T.	10 s	
37	CYCLE PAUSE	50 s	
38	OC TOLERANCE	1 %	
39	INFORMATION	TORQUE	
40	RESTORE BACK.	START	
41	CREATE BACK.	START	
42	RESTORE FACT.	START	
43	ACTIVE ERR:	CLEAR	

Other parameters set-up is possible to change only by using the PC software

NAME	FACTORY SETTING-UP
DIRECTION OF ROTATION	clockwise
THERMOSTAT TEMPERATURE	25 °(space heater OFF temperature)
CYCLE POSITION O1	0 %
CYCLE POSITION O2	100 %
CYCLE POSITION C1	0 %
CYCLE POSITION C2	100 %
LCD CONTRAST	0

Warning 1: When the input control signal is set to the value 0 , 20 mA (0 to 10 V), or 20 , 0 mA (10 to 0 V) and the input control signal fails, then the EA keeps the position as with a 0 mA (0 V) input signal (EA doesn't recognise between input signal fail and 0 mA (0 V) input signal).

Warning 2: Auto-calibration process doesn't run if triggered in time when the EA is in error state, e.g. EA is overloaded (EA is switched -off from torque). In such case is necessary to resolve issue, e.g. the EA must be moved in a position in which is not switch-off from torque and to start the auto-calibration again.

Warning 3: Calibration process must be performed at any change of the operating angle value of more than 10%.

Warning 4: Operate adjusting button **P** on the control to activate the calibration process or start it from **MENU 4** in the version with local control (use the buttons on local control) or from the programme once the EA is connected to the PC. All calibration start methods have been equal.

Warning 5: In case that EA with supply voltage 3x400V AC after calibration start shows the error „rotation direction“ (error No. 7), it is necessary to stop EA by switching-off the supply voltage and change the phases sequence on the terminals 2 and 3 (change mutually phases wires) and after switching-on the supply voltage run n the calibration again.

Rotation direction definition of the electric actuator's output element:

Electric actuator is set by the producer in the following way: while looking at the output shaft of the actuator from the upper cover side, the output shaft moving in the direction "Close" is rotating clockwise. It means that the direction of rotation of the actuator is set as **clockwise**.

In case the direction of rotation shall be changed the parameter „Direction of rotation of the actuator“ must be adjusted as **anticlockwise**. This parameter can be adjusted through the PC only by use of the EHL Explorer SW. The PC must be connected to the actuator via communication cable and the window "Parameters" used for direction adjustment.

4.3 Putting an EA into operation when the EA is set up and connected with the armature already in the production plant (starting the calibration)

If EA is delivered from manufacturing plant joined with valve, or with control device, **calibration** must be performed to ensure correct operation, under actual pipeline conditions.

The procedure is as follows:

- fit the given assembly into the specified technology complex
- connect the EA on the supply voltage electrically according to the wiring diagram and chapter Electric connection and checking of function.
- introduce the EA into an mid-position (see Note 2 presented above)
- switch on the supply voltage
- **start the EA calibration** by pressing the **P** button on the control unit **for 2 seconds as minimum** until LED ERROR (red), LED MENU (green) and LED PAR (red) light up – see also the procedure in the separate attachment **No.74 1053 02**
- release the **P setting button**
- after releasing the **P** button the calibration procedure starts – inertia measuring
- after the calibration procedure is finished, the EA is prepared for its operation and starts to response to control inputs
- if changes to some parameters would be necessary, proceed please according to the instructions given in the separate attachment **No. 74 1053 02**.

4.4 Putting an EA into operation when the stroke and parameter setting done by the producer suit to your needs

When an EA is delivered from the producer without armature and the setting of stroke (stroke end positions) and other parameters done by the producer suit Your needs, please proceed as follows:

- connect the EA with the armature to be controlled (**according to chapter 2**) and fit this assembly into the specified technology complex
- connect the EA electrically according to the wiring diagram and chapter Electrical connection and checking of function
- introduce the EA into an mid- position (see Note 2 presented above)
- switch on the supply voltage
- start the EA calibration by pressing the **P** button on the control unit **for 2 seconds as minimum** until LED ERROR (red), LED MENU (green) and LED PAR (red) light up – see also the procedure in the separate attachment No. 74 1053 02
- release the **P** setting button
- after releasing the **P** button the calibration procedure starts

- after the calibration procedure is finished, the EA is prepared for its operation and starts to response to control inputs
- if changes to some parameters would be necessary, proceed please according to the instructions given in the separate attachment No. 74 1053 02.

4.5 Putting an EA into operation when it is necessary to do a change to the stroke (setting new end positions), and the other parameter setting done by the producer suits to your needs

When an EA is delivered from the producer without armature, and the setting of other parameters done by the producer suit to your needs, and it is necessary to do a change to the EA stroke, proceed as follows:

- connect the EA with the armature to be controlled (according to chapter 2) and fit this assembly into the specified technology complex,
- connect the EA electrically according to the wiring diagram and chapter Electrical connection and checking of function,
- turn on the power supply, without connection of the control signals fed into ES (input control signal - ES reports error/warning No.2 - no binary input),
- set the ES (*using manual control**) to end position **closed** and push button **C** for at least **2s**, until LED ERROR (red), LED MENU (green) and LED PAR (red) come on – the **closed** end position is thus recorded in memory – see description in separate annex **No. 74 1053 02**,
- release the **C** setting button,
- set the ES (*using manual control**) to end position **opened** and push button **O** for at least **2s**, until LED ERROR (red), LED MENU (green) and LED PAR (red) come on – the **opened** end position is thus recorded in memory – see description in separate annex **No. 74 1053 02**,
- **release** the **O** setting button,
- **introduce** the EA into an mid osition (see *Note 2* presented above),
- by pressing the **P** pushbutton on the control unit **for at least 2s** activate the EA calibration until LED ERROR (red), LED MENU (green) and LED PAR (red) come on – see also description of the procedure in separate annex **No. 74 1053 02**,
- release the adjustment pushbutton **P** - upon release of the **P** pushbutton, the calibration process is started,
- turn on the control signals, EA is ready for operation and responds to control inputs,
- if any of the parameters need to be changed, proceed according to the instructions in separate annex **No. 74 1053 02**,

** This applies to setting of EA to be controlled by 2P and 3P or 3P/2P switched by I2, at the same time with standard setting of menu 9 FAILURE REACTION: STOP!*

4.6 Setting other parameters

If changes to some parameters would be necessary, proceed please according to the instructions given in the separate attachment **No 74 1053 02**.

4.7 Error messages from the control unit

The EA electronics makes possible to identify some failures of EA. The failure is signalled by flickering LED ERROR (red) on the control unit (**Fig.6**). An error has also been indicated on the LED display. An error is indicated on the LCD display in the local control EA version.

The list of errors and warnings compiled by the producer is presented in **table 5** (chapter 5.4).

The list of errors and warnings and the way for identifying a given error as well are presented in the separate attachment No **74 1053 02**.

A field serviceman is only entitled to change the errors and warnings set using the programme once the EA is connected to the PC.

4.8 Adjustment of the operating angle position and adjustment of stop screws (Fig.10-14)

The stop screws serve for mechanical limitation of the elevation (operating angle) of the electric actuator during manual operation or as the path endpoints for switching-off from torque. Thus the output backstop must not foul them during motor-driven operation without adjusted torque unit. Otherwise damage

of mechanical transmission could occur. On following figures you can find shown all possible settings of operation angle for angle 90°, where Fig. a) - output shaft in position „Z" ("closed"), Fig. b) – output shaft in position „O" ("open").

Adjusting of stroke 90° - without changed position of operating angle (0°)

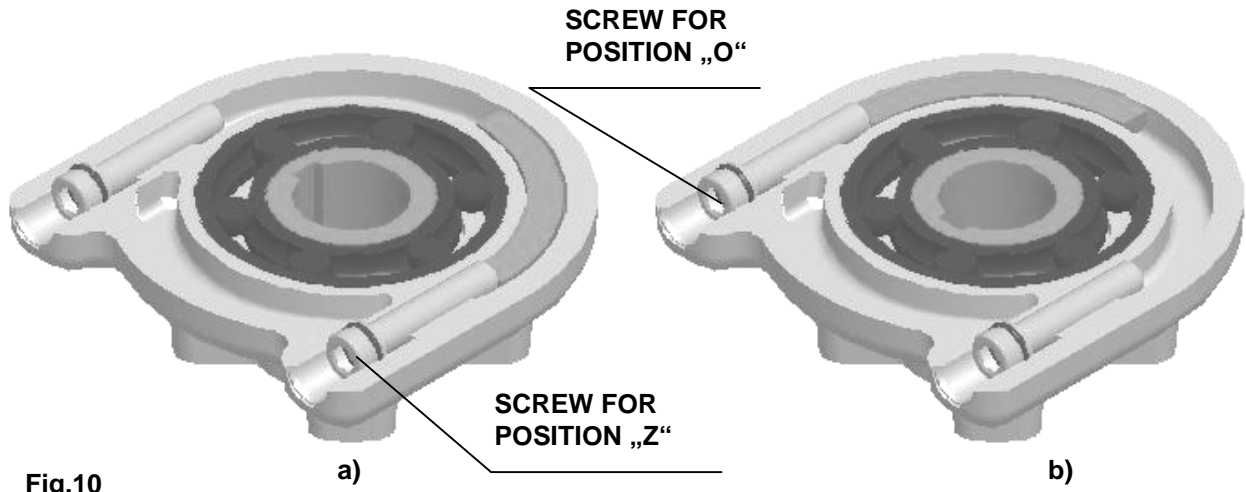

Fig.10

Backstop screws serve also for setting of the armature operating angle, they allow to change this position from "Z" (0°) and from position "O" (60°, 90°, 120°, 160°) by value $\pm 10^\circ$, whilst the operating angle amount specified on the EA type plate must remain unchanged.

Adjustment of stroke 90° - with changed position of operating angle +10° in direction „O“ (open)

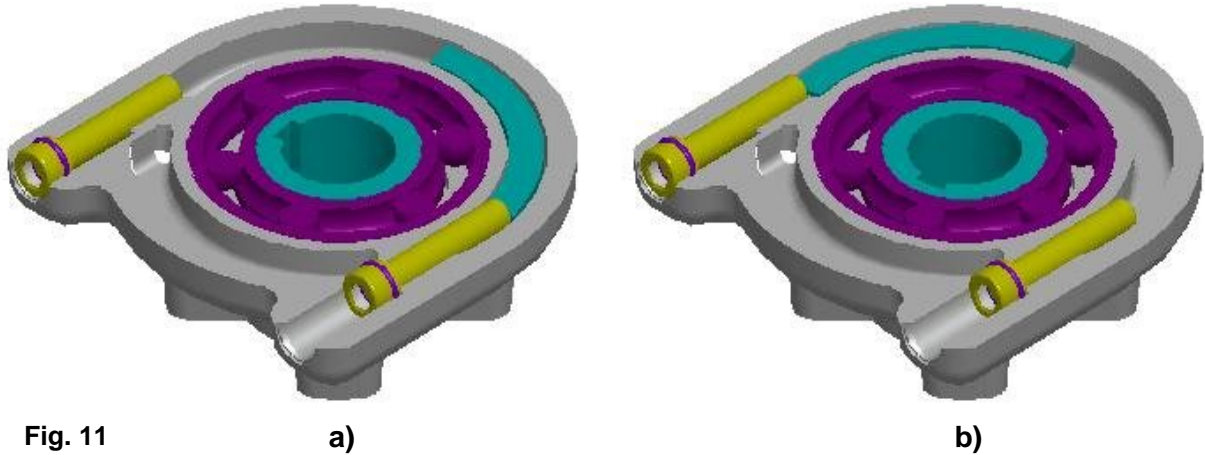

Fig. 11

Adjustment of stroke 90° - with changed position of operating angle +10° in direction „Z“

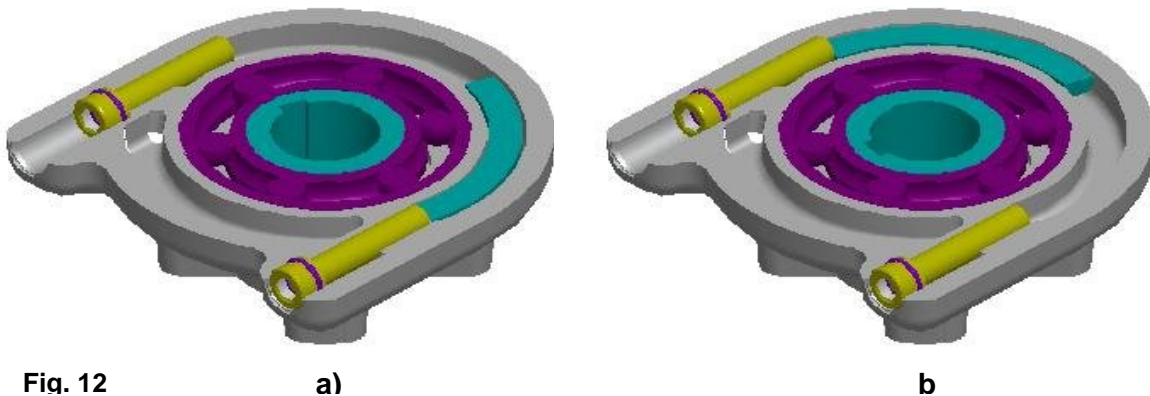

Fig. 12

4.8.1 Adjusting of backstop screws during switching-off the EA from position unit

If EA is equipped with torque switches thus these fulfill the function of limit switches in case when EA is not switched-off from the position unit switches, eventually they fulfill also protective function against overloading of EA.

Procedure:

- release both backstop screws in such way that their heads shall be on the same level as the opening edge (Fig.13)
- readjust the EA into position „Z“ (“closed”) until disconnection of the position switch
- rotate the backstop screw to the right until you feel increased resistance when bumped the backstop. Under such achieved status turn the screw by 1/2 rotation backwards as minimum to avoid sooner connection from the torque unit,
- perform similar adjustment of the backstop screw for position "O" (“open”).

4.8.2 Adjusting of backstop screws during switching-off the EA from torque

When using the backstop screws as endpoints (backstops) for the EA output shaft path thus the EA must have the torque unit adjusted in such way that no overrunning of the switching-off torque could occur.

Procedure:

- by means of manual wheel readjust the EA into position "Z" ("closed"),
- release both backstop screws in such way that their heads shall be on the same level as the opening edge (Fig.13)
- rotate the backstop screw for position "Z" ("closed") to the right until you feel increased resistance when bumped the backstop
- perform similar adjustment of the backstop screw for position "O" ("open"),
- adjust the position and signaling unit in such way that it should connect after switching-on the torque unit.

Remark:

It is possible to increase (Fig.13) or decrease (Fig.14) the operating angle by 26° on adjusted EA by means of backstop screws, but you are loosing possibility of the output shaft position tuning. In doing so, the positioning unit must be adjusted to this angle and transmitter must be ejected from angle.

Adjustment of elevation angle 110° - increasing of the operating angle by 20°

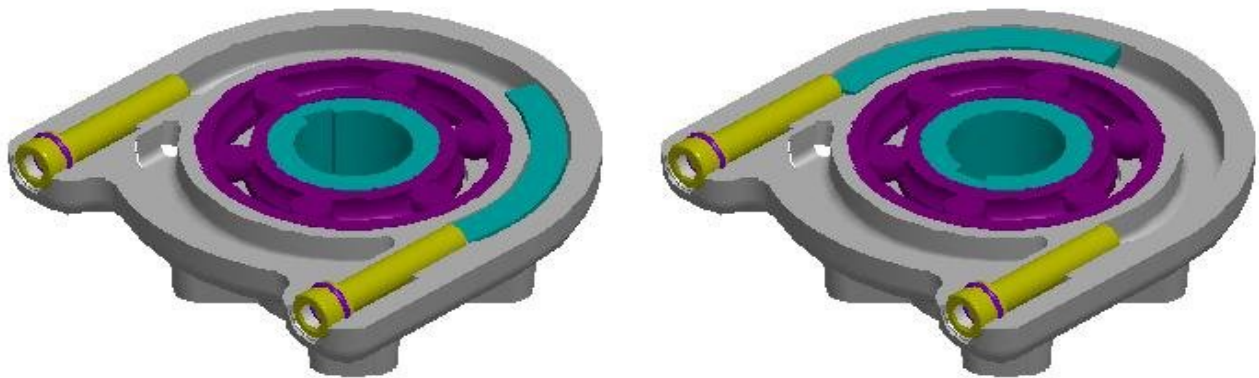

Fig. 13

a)

b)

Adjustment of elevation angle 70° - reduction of the operating angle by 20°

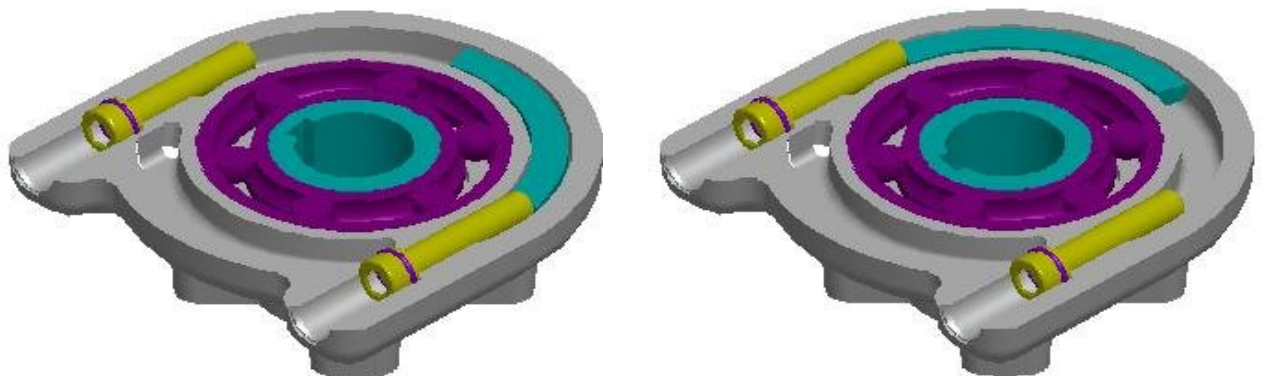

Fig. 14

a)

b)

5. Service and Maintenance

5.1 Service



1. In general it is supposed that the EA is serviced by a qualified person as required in the Chapter 1!
2. After the EA is put into operation it is necessary to check whether during manipulation its surface finishing was not damaged – the damages should be eliminated to prevent the surface against deterioration caused by corrosion!

- The EA requires just an insignificant service. The reliable operation is determined by the correct putting into operation.
- The service of the EA results from the operation conditions and generally consists in treating the information for subsequent performing of a required function. The EA can be controlled by remote control electrically or manually on the place of their installation. The manual control is available with a handwheel.
- The stuff has to perform prescribed maintenance to prevent the EA during operation against impacts of environment, which exceed the frame of allowed influences.

At a power outage or voltage breaking off, an electric actuator will stop in a position, in which it had been before the power outage occurred. In case of need it is possible to preset the electric actuator with manual operation .

Manual control:

- If the manual control is needed (adjustment, function checking, failures etc.) the staff can reset the regulated member using the handwheel. While rotating the handwheel clockwise the output element moves in the direction “CLOSING”.

Electric local control: - additional equipment (Fig.15)

If necessary in the case of accession, function check and so on, it is possible to preset EA or change some parameters by local electric control with secured power feeding.

It is possible to control after removing of the padlock (1). Control mode selection is changed by sequential pressing of the button (2) **REMOTE-OFF-LOCAL** to “Remote” “Shut off”, “Local”, “Shut off”, which is displayed on 2 rows LCD (6). Signalling motion and failure of the EA is also indicated by LEDs diode (7).

Mode “Shut off” – it is possible to change some parameters in this mode in particular menus.

Mode “Local” – it is possible to control EA by the local buttons in this mode - (3) **OPEN**, (5) **STOP**, (4) **CLOSE**.

Mode “**REMOTE**” – it is possible to control EA by the commands from superior remote system

Proceeding in setup of particular parameters in the mode “**SHUT OFF**” is described in the independent amendment No. 74 1076 02, which is delivered together with EA equipped by local electric control.

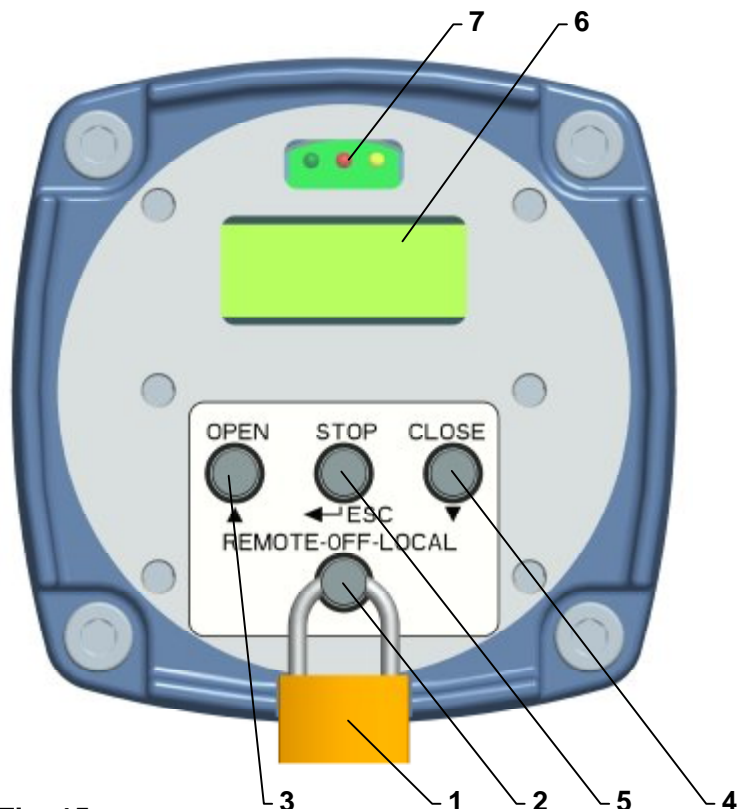

Fig. 15

When you finish the work in the "REMOTE" mode put the padlock on the button (2) again. This measure would be received because of potential unauthorized person's intervention.

Note: Modes of Local or Remote control is conditioned by program choices of inputs I1 and I2. In the case that inputs I1 or I2 are programmed for "Local releasing", it is only possible to control the EA by local control with active input I1 or I2.

5.2 Maintenance - extent and periodicity

During inspections and maintenance is needed to tighten all screws and nuts that affect the tightness and coverage. Similarly, once a year should be checked and if necessary tighten mounting screws of the terminal wires and assuring of the slip-on joints with wires.

The interval between two preventive inspections is four years.

The replacement of cover gaskets and gasket of an oil filling is needed in case of damage or after 6 years of the operation.

The grease in the supplied actuators is designed for the lifetime of the product.

It is not necessary to change the grease during the operation of the actuator.

Lubrication:

- gear part - in versions for climate with temperatures -25°C till +55°C – grease HF 401/0 (GLEIT-μ) resp. GLEITMO 585 K
- in versions for climate with temperatures -50°C till +40°C grease ISOFLEX TOPAS AK 50
- in versions for climate with temperatures -60°C till +40°C grease DISCOR R-EP 000.



Lubrication of the valve stem is independent on maintenance of the EA!

After every potential flooding of the product check, whether there is no water inside. After eventual water penetration, dry the product before repeated putting into operation and replace damaged sealings, resp. other parts of EA. identically check also tightness of cable bushings and replace them, if they are damaged.

- Every six months it is recommended to perform one check move in frame of adjusted operation stroke to verify reliability of functioning with setting back to the original position.
- If the audit rules do not determine else the inspection of EA is performed ones a year and tightening of all connecting and grounded screws have to be checked to avoid overheating.
- After 6 months from putting of EA into operation and once a year it is recommended to check tightening of fixing screws between the EA and the valve. (Tighten the screws with the cross system.)



- While connecting and disconnecting of the EA check the tightness of cable glands – those with damaged sealings should be replaced by new ones of the approved type!
- Keep the EA clean and take care about removing impurities and dust. The cleaning has to be performed regularly according to the operation possibilities and requirements.

5.3 Troubleshooting

At failure of power supply the EA stops in the position where it was before the failure. If needed the EA can be set only with the manual control (the handwheel). After restoration of power the EA is prepared for operation.

In case of failure of any element of the EA it can be changed by a new one. Entrust the change to a service centre.

If your EA would fail, proceed please according to the instructions for the under guarantee and after-guarantee.

Note: If the EA requires dismantling follow the chapter "Dismantling".

The EA electronics makes possible to identify some failures of the electric actuator. The control unit blinking LED ERROR indicates the failure (**Fig. 6**) or the error is displayed on the LED (**see Fig. 1**), or the LCD display (**see Fig. 15**). The list of errors and warnings and the way for identifying a given error as well are presented in the separate attachment No 74 1053 02.

The list of errors and warnings compiled by the producer is presented in **table 5**. A change to the list of errors and warnings in the EA is only possible within a service intervention, through the program installed in a PC.

Table 5 setting error flags and warning flags as at the delivery		
PARAMETER	ERROR	WARNING
ESD		X
Analog Input		X
Wrong command	X	
Torque		X
Torque check		X
Torque calibration	X	
Regulator calibration		X
Stroke (turns sum)	X	
Wrong position	X	
Spin	X	
Spin direction	X	
RAM	X	
ROM	X	
EEPROM		X
Bus	X	
I2C	X	
Reset		X
Voltage +5V		X
Parameters	X	
Set mode		X
Relay		X
Temperature <		X
Temperature >		X
Phase	X	
Power frequency	X	
Thermal fuse	X	
Manual control	X	
Position module	X	
Position module type	X	
Position sensor 1	X	
Position sensor 2	X	
Position sensor 3	X	
Position sensor 4	X	
Torque module	X	
Torque module type	X	
Torque sensor	X	
LED module	X	
LED module type	X	
LCD module	X	
LCD module type	X	
Power Supply/Relay module	X	
Power Supply/Relay module type	X	

Notes: **X** – the error or warning flag is activated.
 With the **error flag**, the EA takes the position defined for the FAILURE REACTION function eventually stops (depending on the kind of the error), and it will not operate until the error is removed.
 With the **warning flag**, the EA continues in operation.
 The user is advised on error or warning through the READY relay (according to the relay setting), eventually through the program after connecting the EA with a PC.

Note 1: In some cases having the error removed the electric actuator must be restarted by switching-off the voltage supply to the electric actuator for about 3 sec.

For repairing eventually the electronics use the fuse – see Fig.1d (F3) for example SHURTER MSF 250, or a sub miniature SIBA 164550 xxx (see chapter 2.2.2), which is located on source board.



Taking the EA to pieces for repair purposes is allowed only by professionally qualified persons trained in the production plant or by a contracted service centre!

6. Accessories and spare parts

6.1 Accessories

The EA is delivered with the **handwheel and cable glands**.

6.2 Spare part list

Spare part			
Spare part	Order Nr.	Position	Figure
Electric motor; 40 W; 230V AC (3x400 V AC); 50 Hz; (UPR 1PA)	63 592 076	2	1
Electric motor; 40 W/110 VA; 3x400V AC; 50 Hz; (UPR 1PA)	63 592 054	2	1A
Electric motor; 120 W/228VA; 230V AC; 50 Hz; (UPR 2PA,-UPR 2.5PA)	63 592 394	2	1
Electric motor; 60 W/120VA; 230V AC; 50 Hz; (UPR 2PA-UPR 2.5PA)	63 592 322	2	1
Electric motor; 20 W/75VA; 230 V AC (UPR 2PA-UPR 2.5PA)	63 592 118	1	1
Electric motor; 180 W/300VA; 3x400V AC; 50 Hz; (UPR 2PA-UPR 2.5PA)	63 592 330	2	1A
Electric motor ; 90 W/150VA; 3x400V AC; 50 Hz; (UPR 2PA-UPR 2.5PA)	63 592 328	2	1A
Electric motor; 40 W/90 VA; 115 V AC, 60 Hz; (UPR 2PA-UPR 2.5PA)	63 592 XXX	2	1
Electric motor; 25 W/120 VA; 60 Hz; (UPR 1PA)	63 592 XXX	2	1
Electric motor; 70 W/125VA; 120 V AC, 60 Hz; (UPR 2PA-UPR 2.5PA)	63 592 XXX	2	1
Electric motor, 120W/228VA;120VAC, 60Hz;(UPR 2PA-UPR 2.5PA)	63 592 XXX	2	1
Electric motor; 53 W/72 VA; 24V DC; (UPR 1PA)	63 592 023	2	1
Capacitor 5 μ F (UPR 1PA)	63 540 001	2	1
Capacitor 7 μ F (UPR 2PA-UPR 2.5PA)	63 540 181	2	1
Capacitor 16 μ F (UPR 2PA-UPR 2.5PA)	63 540 251	2	1
Capacitor 20 μ F (UPR 2PA-UPR 2.5PA)	63 540 252	2	1
Capacitor 8 μ F (UPR 2PA-UPR 2.5PA)	Electric motor components	2	1
Capacitor 9 μ F (UPR 1PA)	Electric motor components	2	1
DMS3 ZS24HM zdroj spínaný 24 V AC/DC	64 051 023	3	1H
DMS3 ZS switch – mode power supply for 230 V AC and 115 V AC	64 051 103	3	1, 1A
Position scanning unit DMS3 SP	64 051 079	4	1, 1A
Torque scanning unit DMS3 ST	64 051 080	6	1, 1A
Control unit of the electronics DMS3 J1 (0/4/12 up to 20 mA, resp.4 up to 12 mA)	64 051 075	2	1, 1A
Control unit of the electronics DMS3 J3 (0/2 up to 10 V)	64 051 061	2	1, 1A
Control unit of the electronics DMS3 J2 (without input and output)	64 051 060	2	1, 1A
DMS3 L2 LED display	64 051 081	7	1, 1A
DMS3 LCD display	64 051 082	6	7
DMS3 H3.4 local control sensor	64 051 084	-	7
DMS3 RE3 Module of additional relays	64 051 065	8	1
Ringlet 105x3 MVQ (local control)	62 732 390	-	-
Ringlet 180x3 AS 568 B/BS 1806 (UPR 1PA)	62 732 155	-	-
Ringlet 202,79x3,53 AS568B/BS 1806 (UPR 2PA,UPR 2.4PA,UPR 2.5PA)	62 732 156	-	-
Steering ring 28 (UPR 1PA) – to temperature -25°C	STN 029295 62 732 255	-	-
Steering ring 28x35,6x4,2 (UPR 1PA) – to temperature -50°C	62 732 391	-	-
Ring 36x28 MVQ (UPR 1PA) – to temperature -50°C	STN 029280.9,62 732 338	-	-
Steering ring 40 (UPR 2PA-UPR 2.5PA) - to temperature -25°C	62 732 164	-	-
Steering ring 40x48,8x6,3 (UPR 2PA-UPR 2.5PA) – to temperature -50°C	62 732 158		
O-ring 44,12x2,62 (UPR 2PA-UPR 2.5PA) – to temperature -50°C	62 732 157		
Ring 50x40 MVQ (UPR 2PA-UPR 2.5PA) – to temperature -50°C	STN 029280.9,62 732 404	-	-

Warning: By supplying spare parts, the manufacturer is not responsible for damages caused by their disassembly and assembly. Installation, replacement of spare parts must be performed by authorized, qualified personnel.

7. Enclosures

7.1 Wiring diagrams

Wiring diagrams EA UPR XPA – for single - phase supply

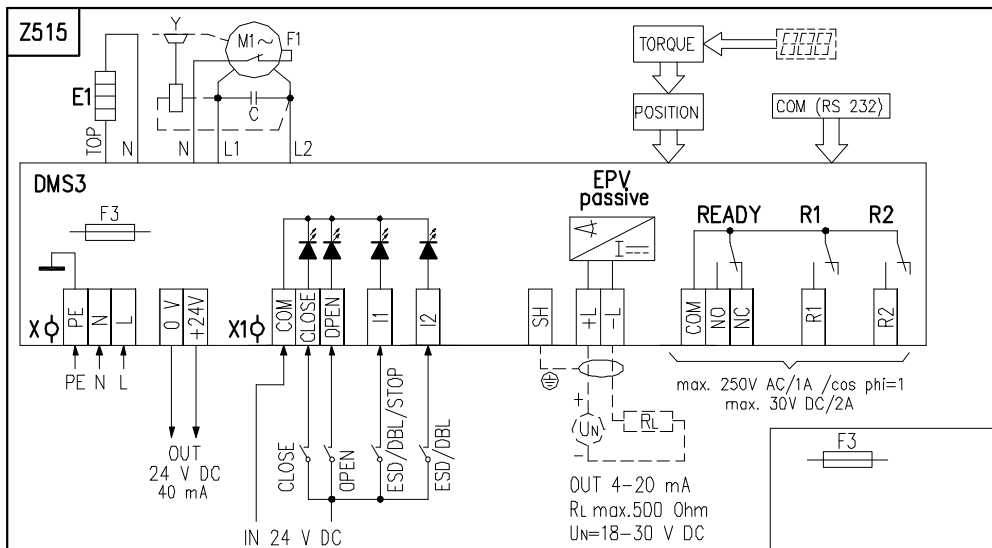
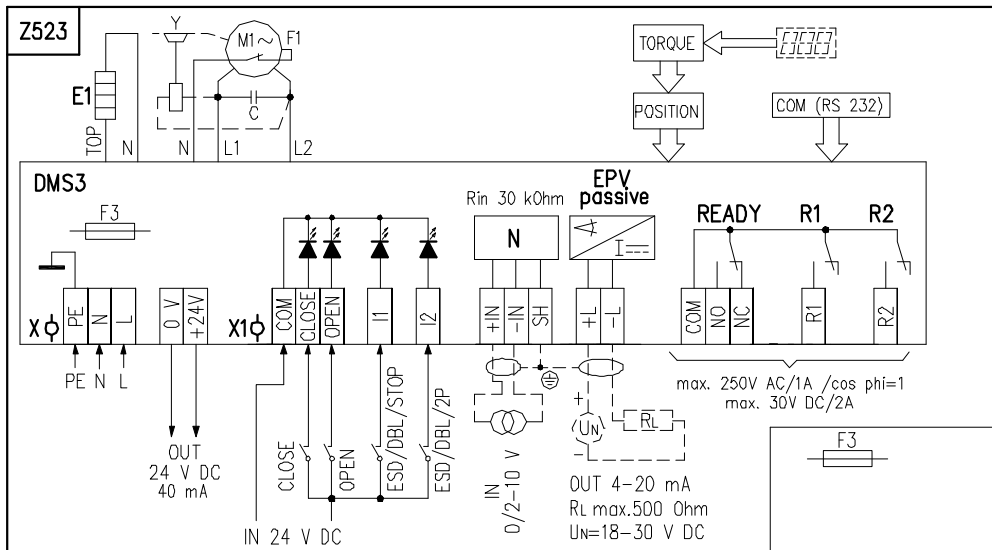
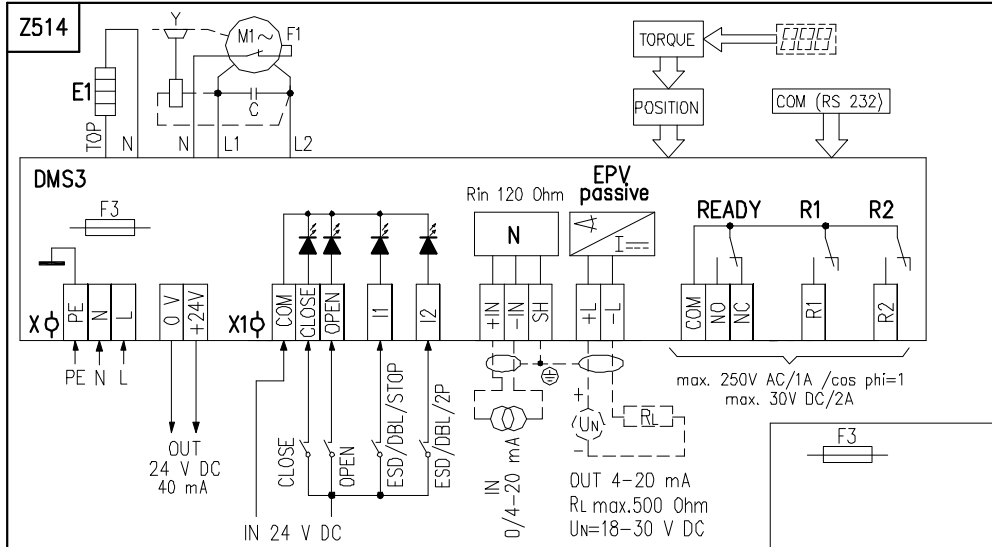

Wiring diagrams EA UPR 1PA – for three - phase supply

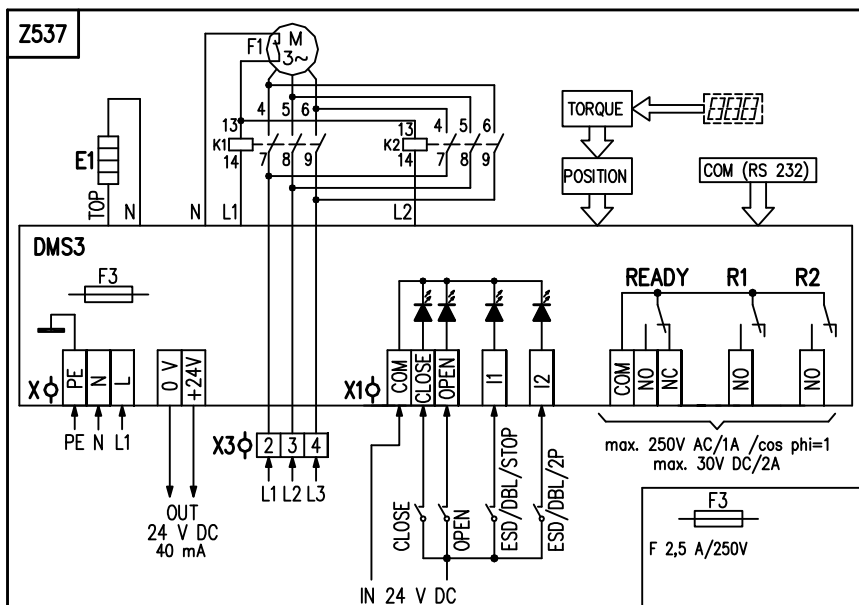
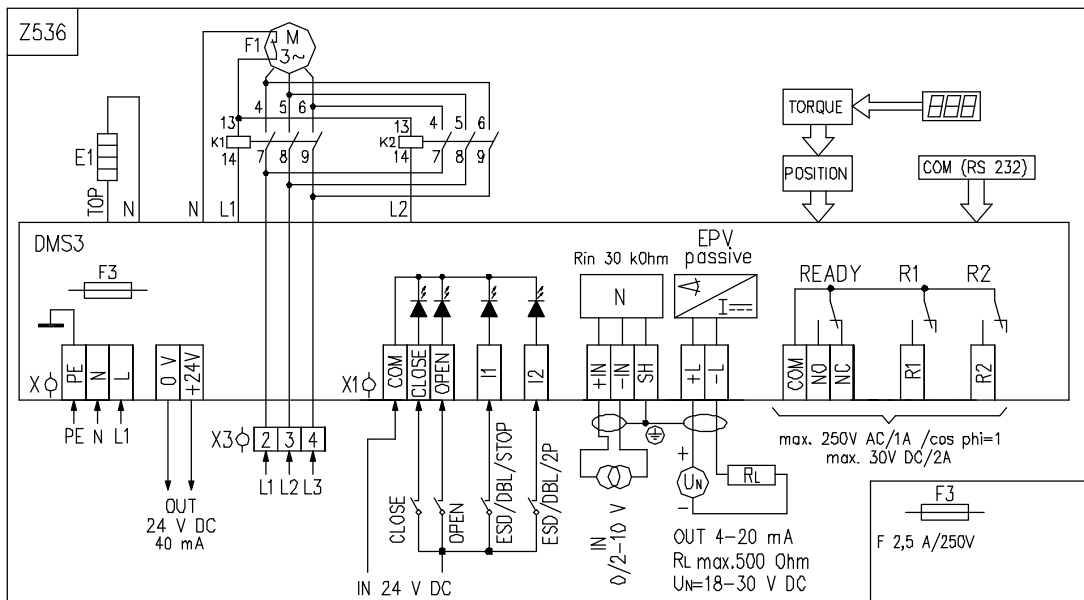
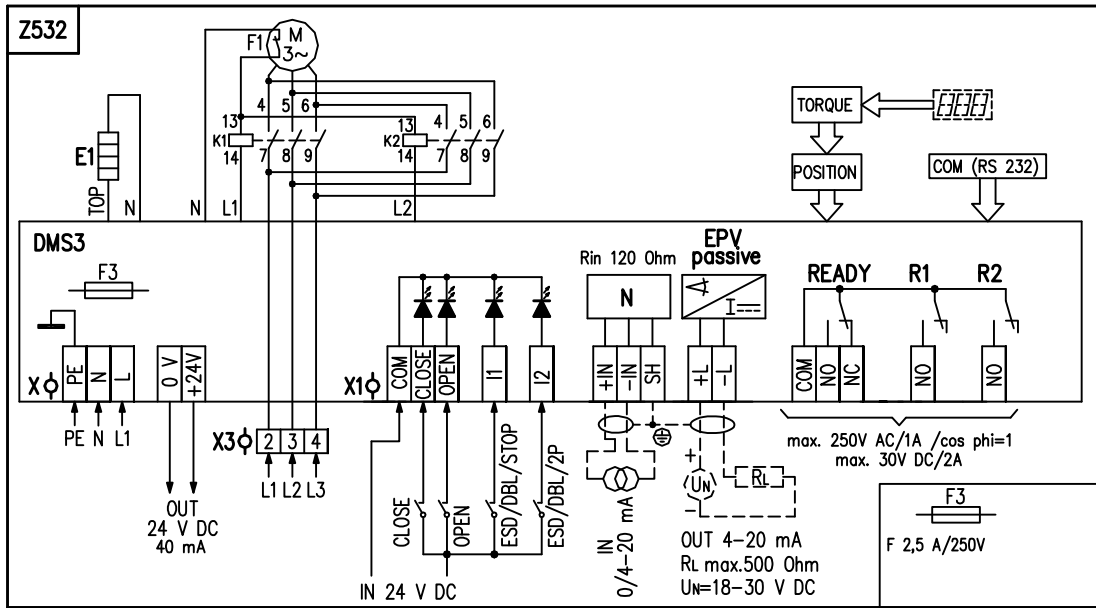

Wiring diagrams EA UPR 2PA-UPR 2.5PA – for three - phase supply with reverse unit

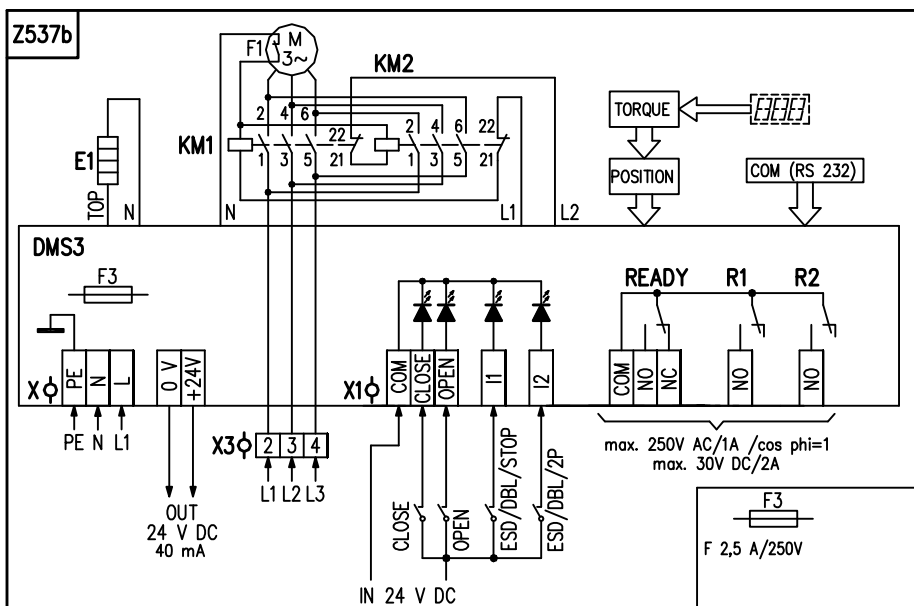
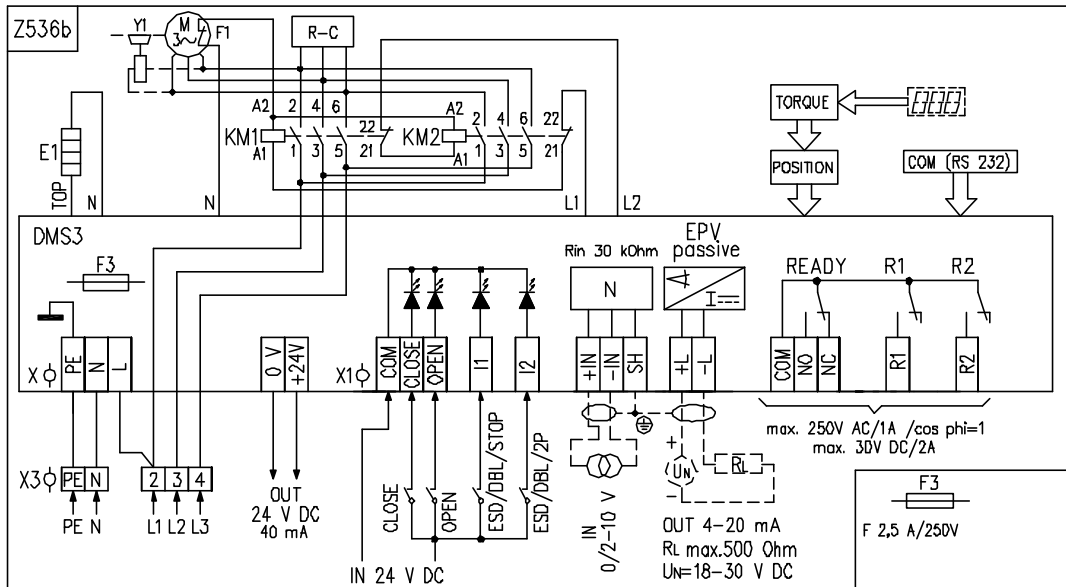
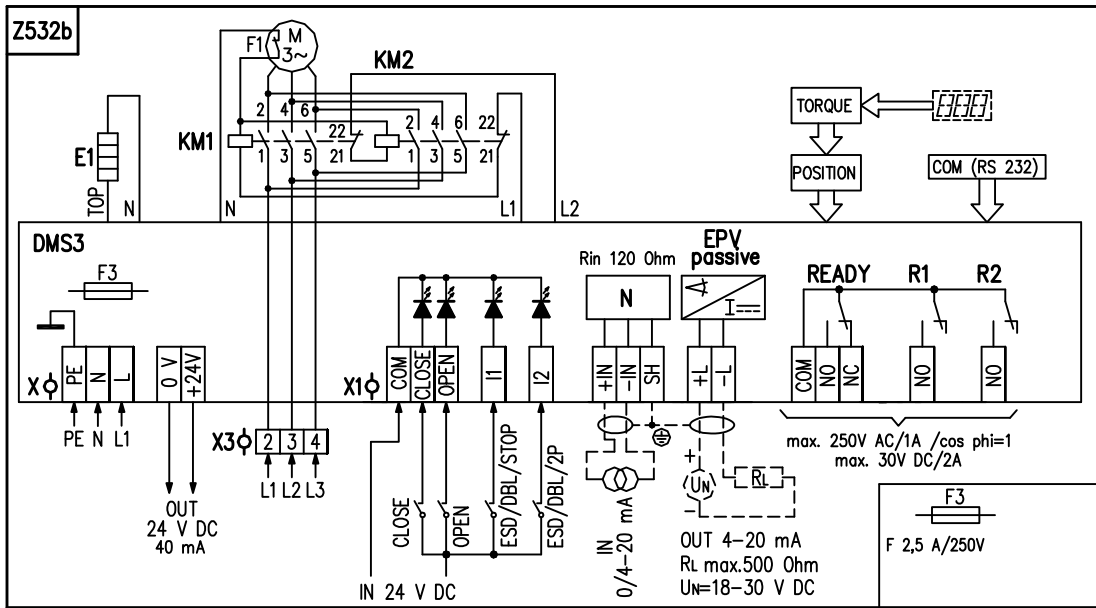

Wiring diagrams EA UPR 2PA-UPR 2.5PA for three - phase supply, with-contactless switching

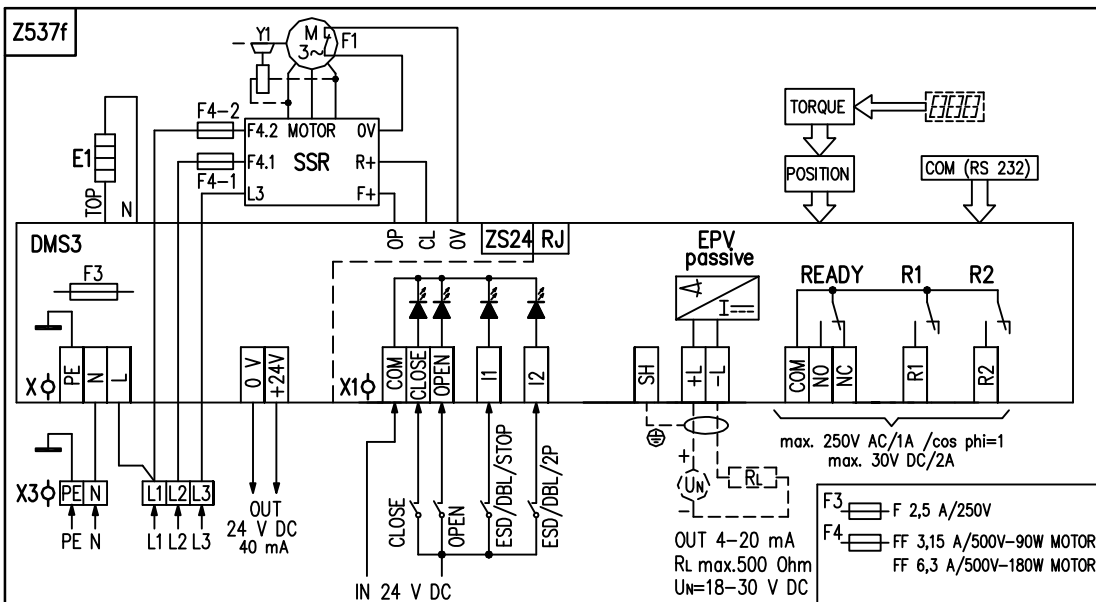
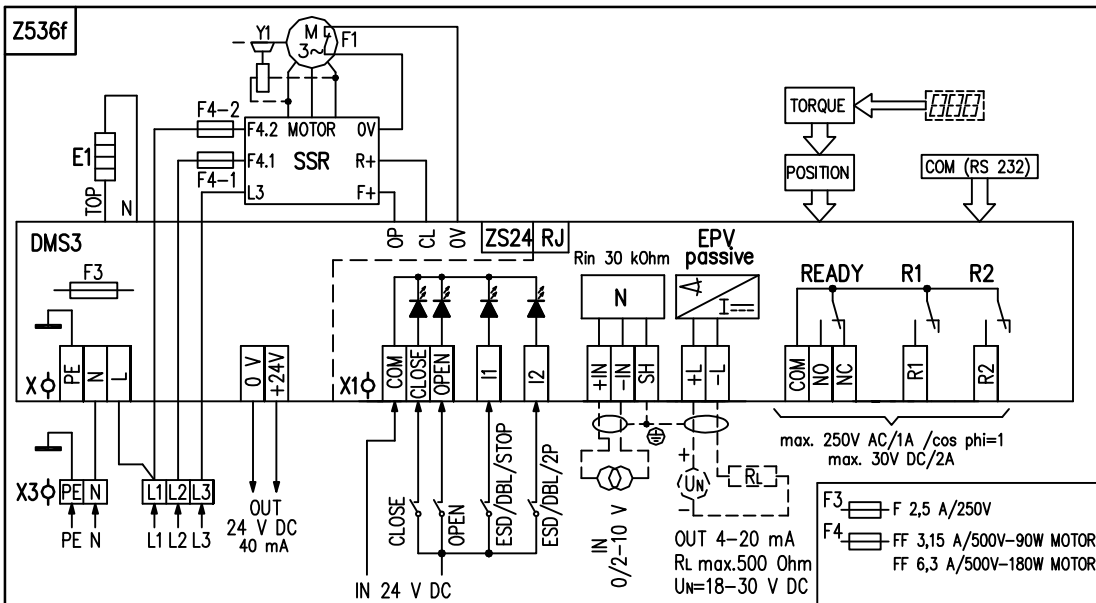
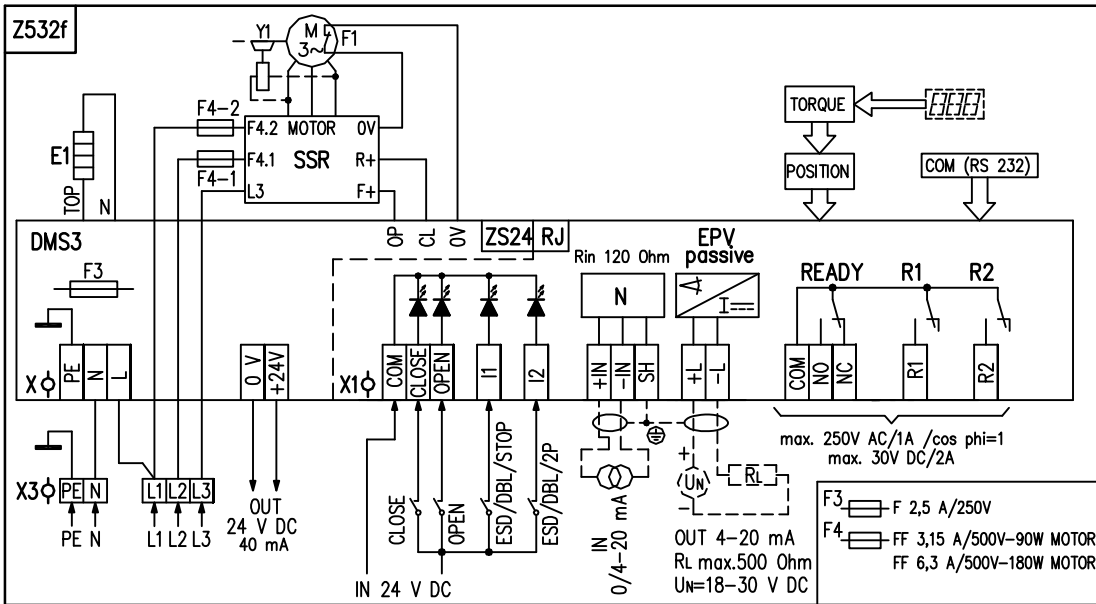

Wiring diagrams EA UPR 1PA – for 24 V AC/DC, UPR 2PA-UPR 2.5PA – for 24 V DC

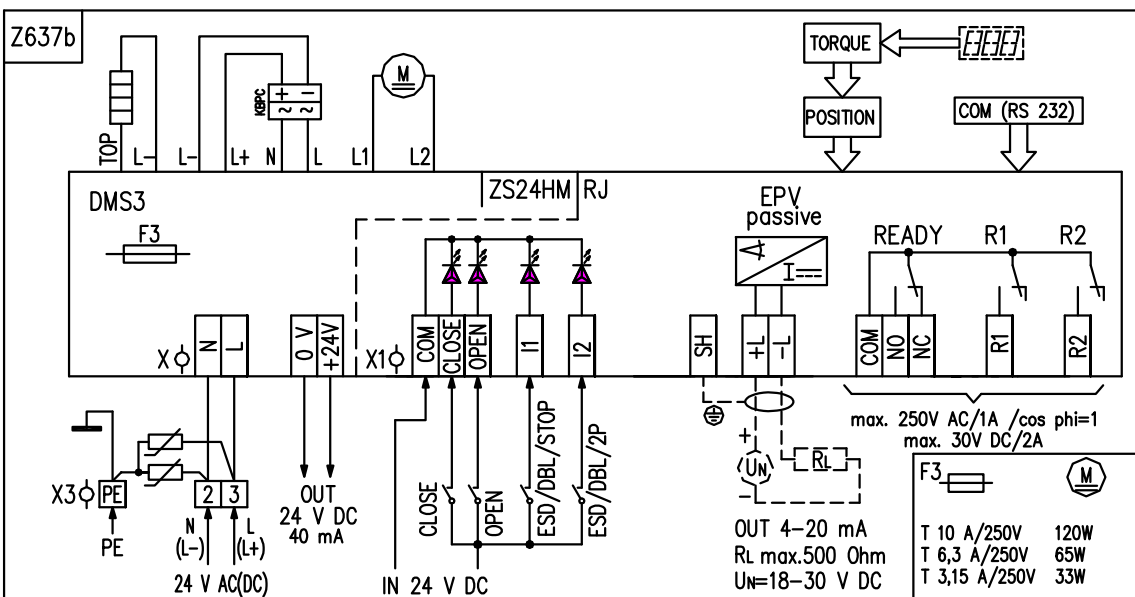
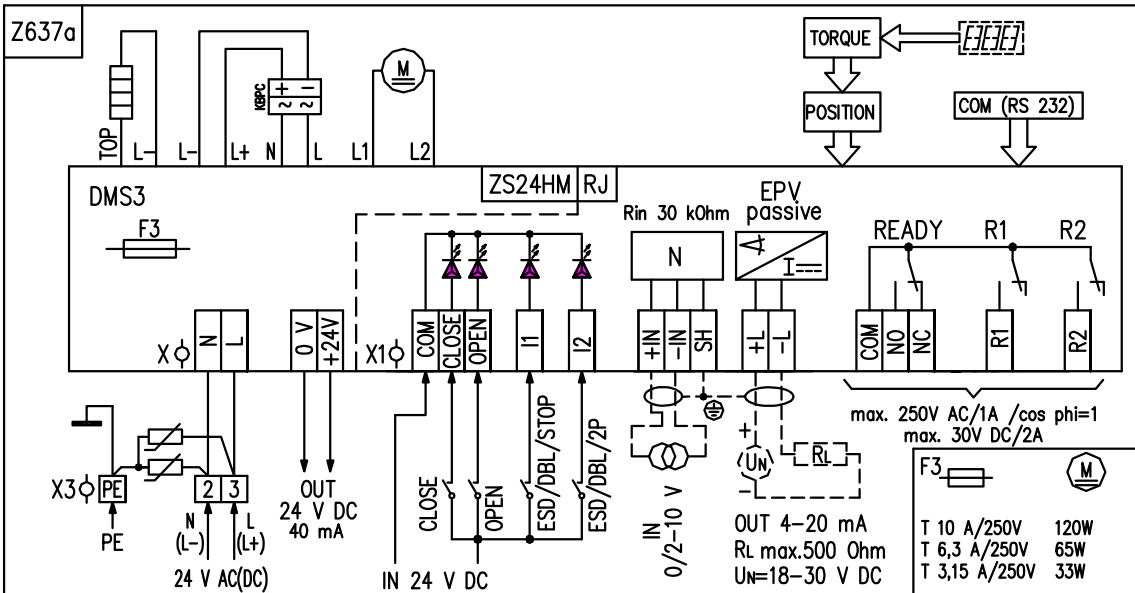
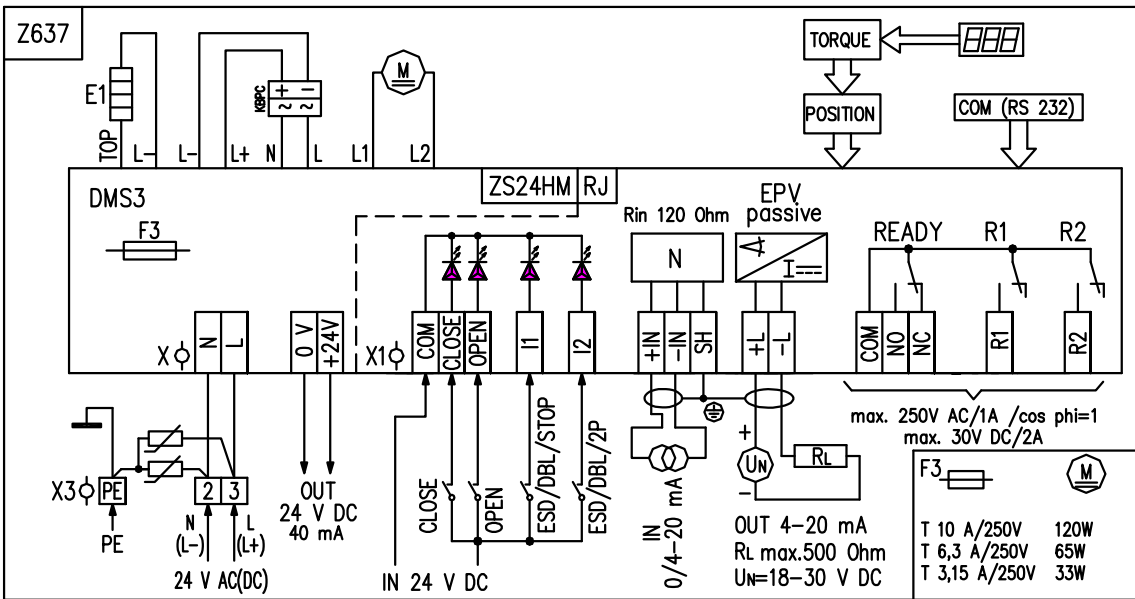

Wiring diagrams EA UPR XPA– single - phase supply – for ambient temperature -60°C do +40°

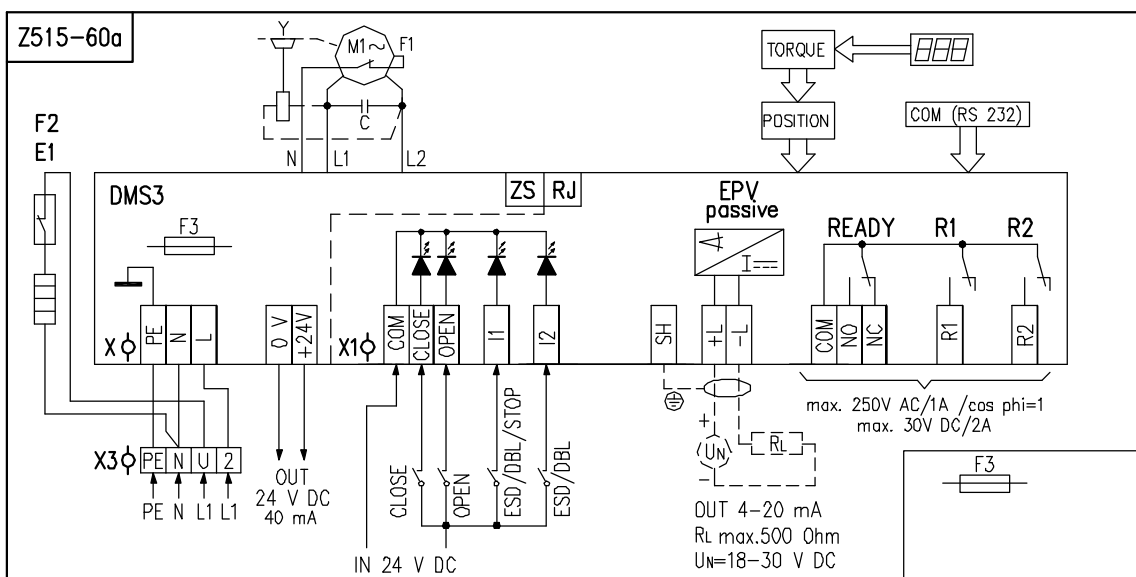
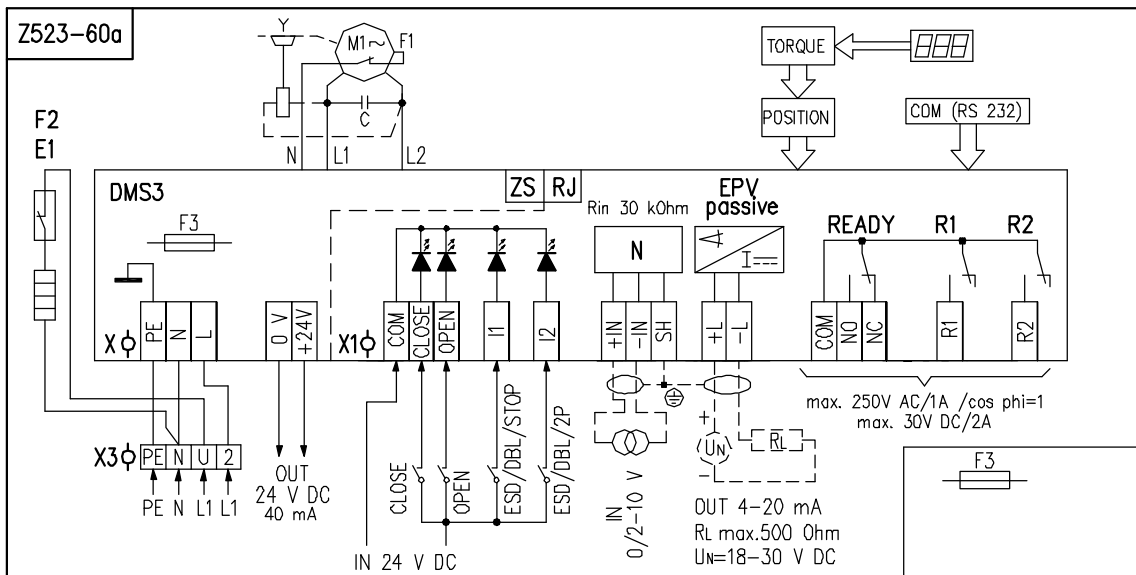
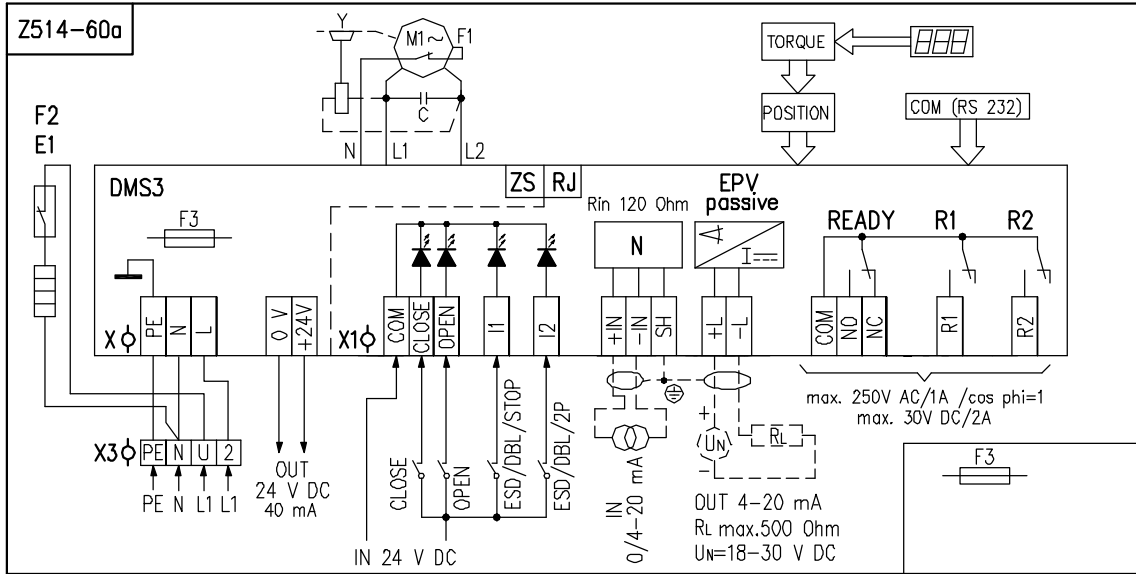

Wiring diagrams EA UPR 1PA– three - phase supply – for ambient temperature -60°C do +40°

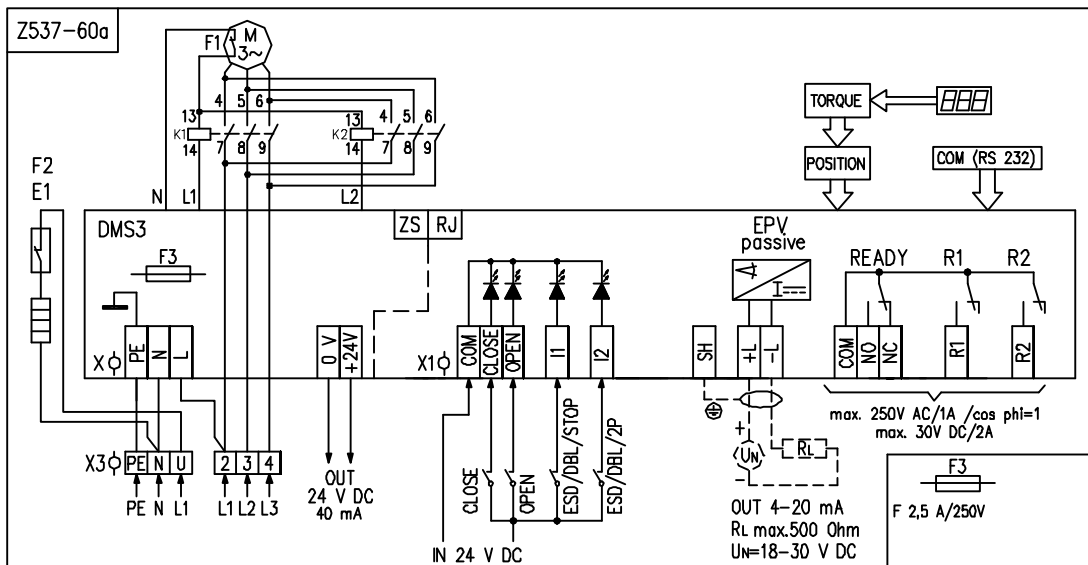
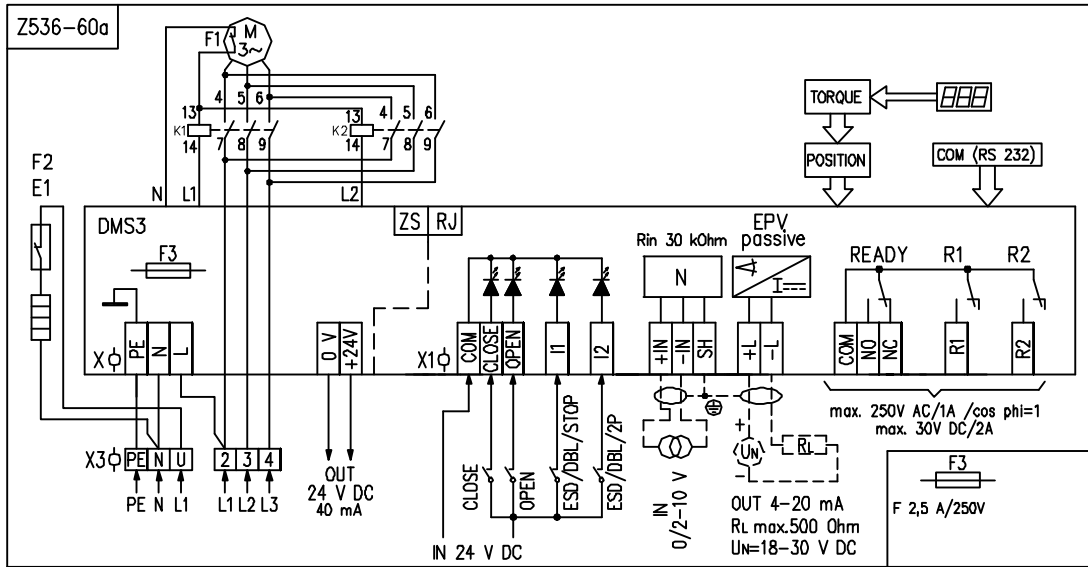
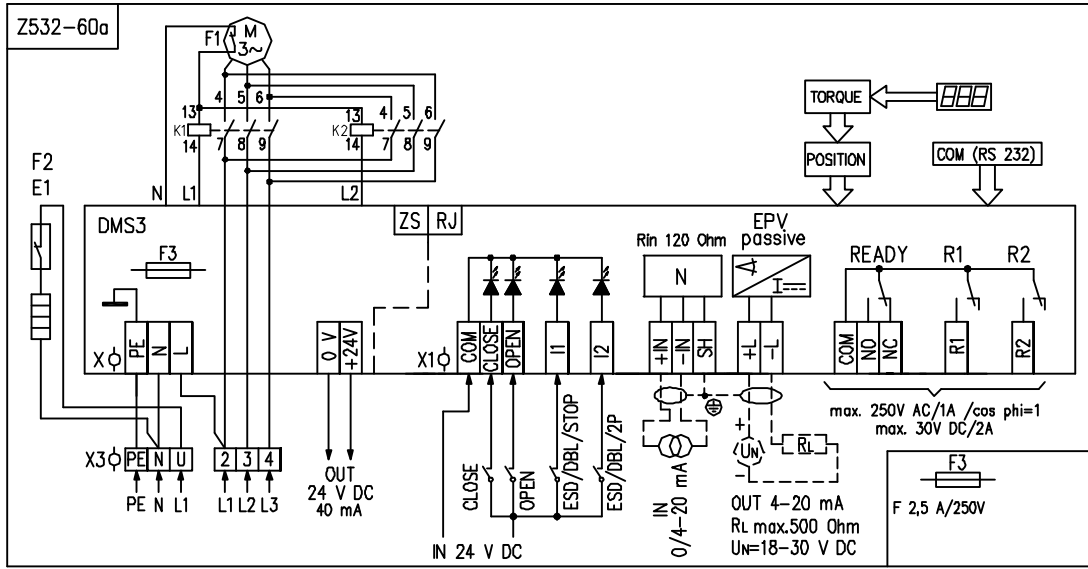

**Wiring diagrams EA UPR 2PA-UPR 2.5PA – three - phase supply, reserve contactors
– for ambient temperature -60°C do +40°**

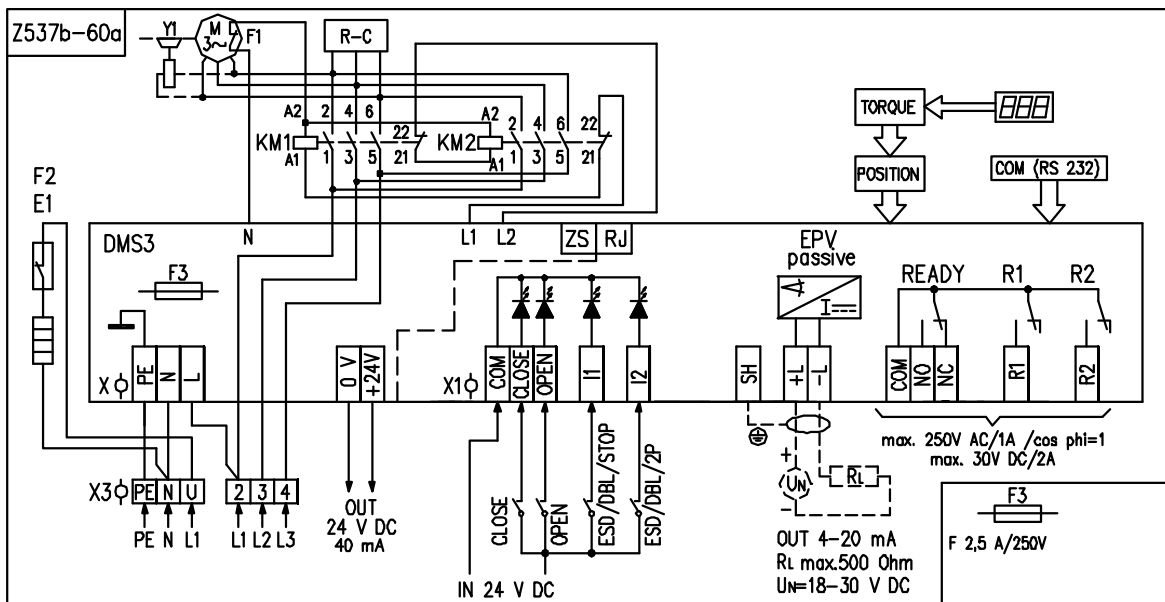
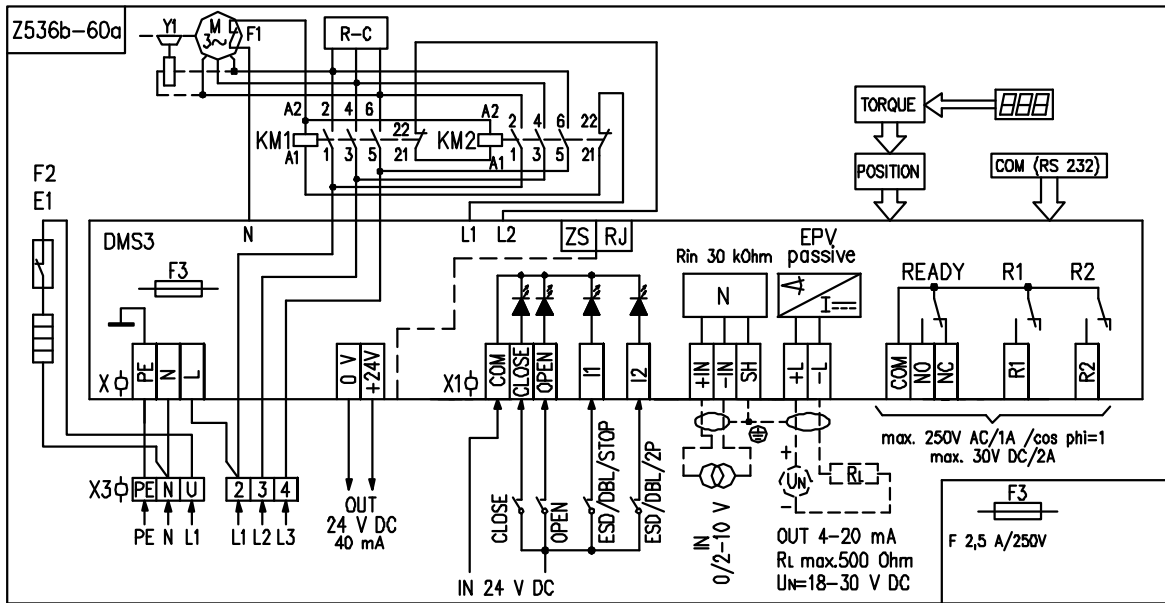
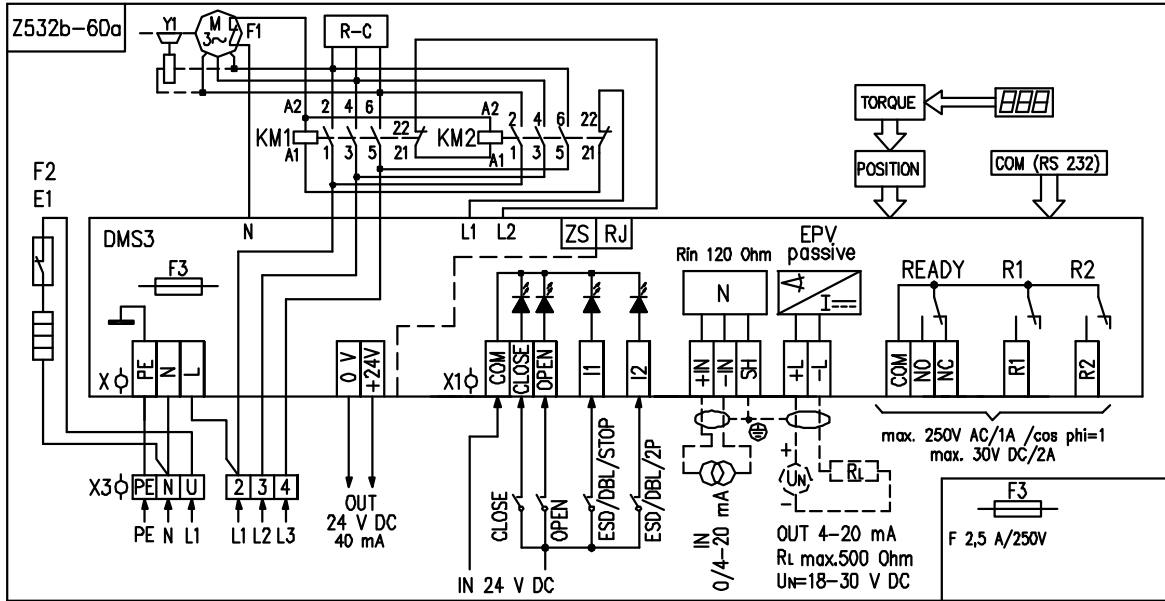

Wiring diagrams EA UPR 2PA-UPR 2.5PA – three - phase supply, with contactless switching – for ambient temperature -60°C do +40°

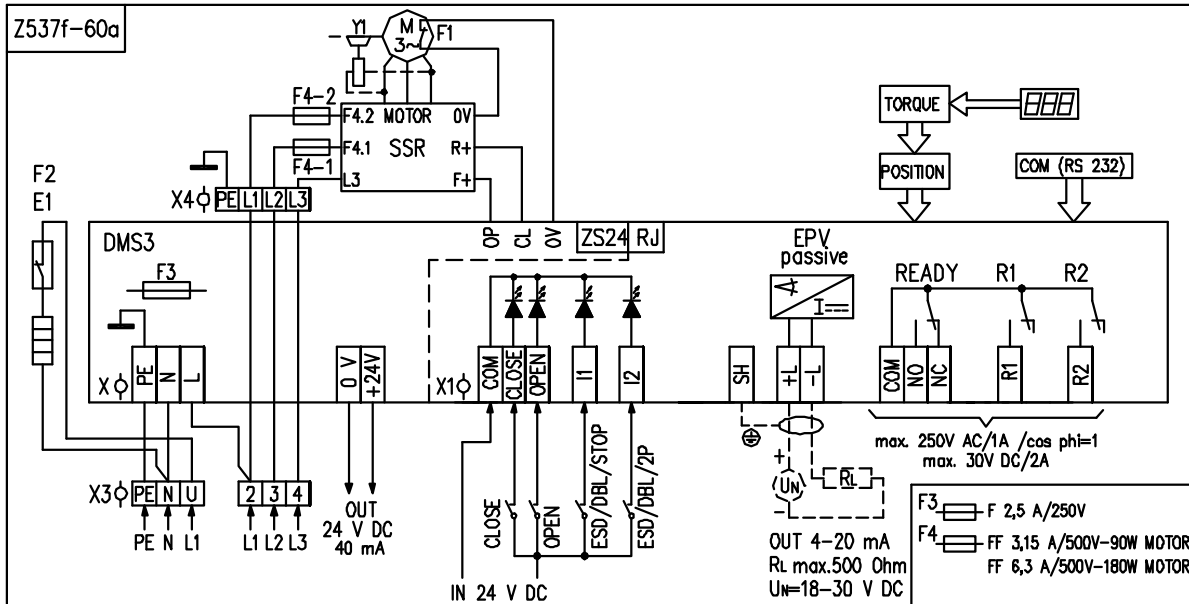
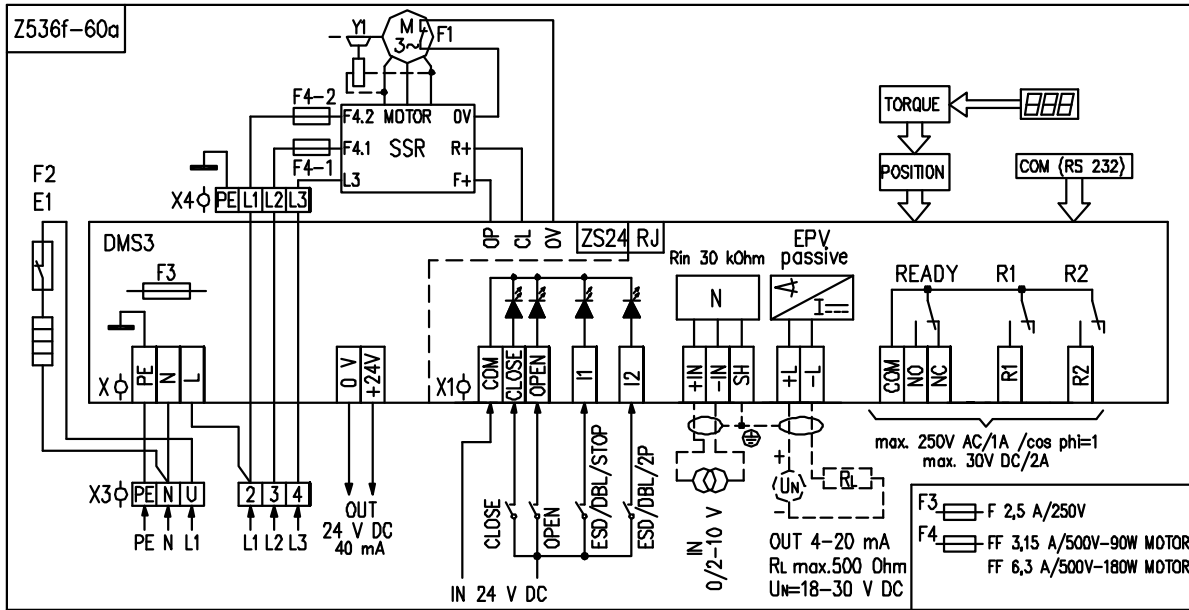
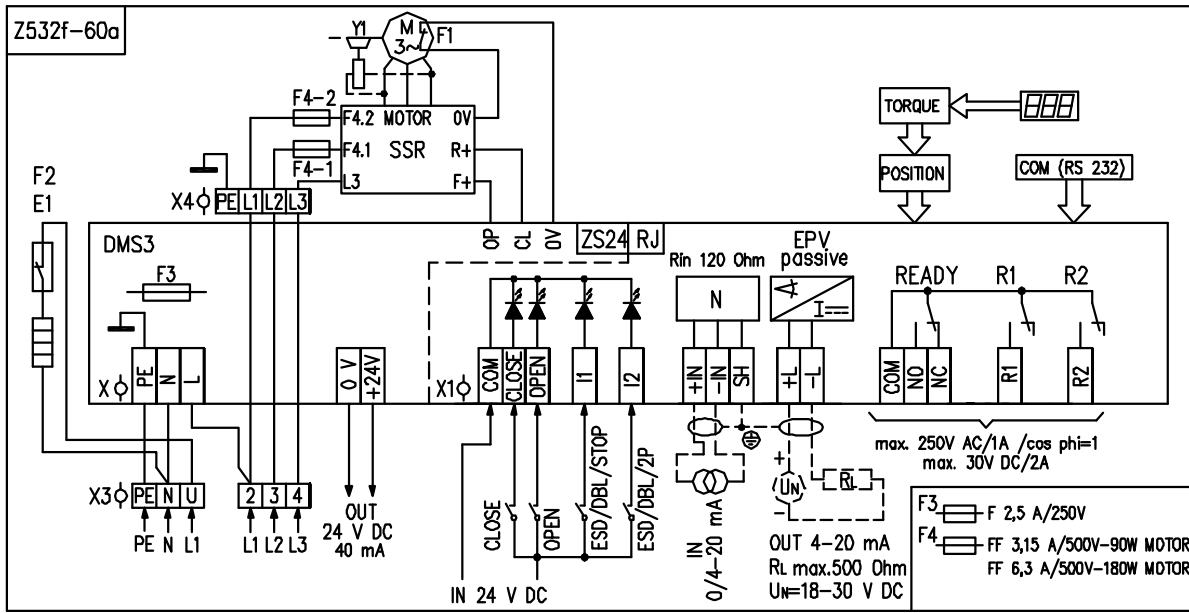

Wiring diagrams EA UPR 1PA – for 24V AC/DC, EA UPR 2PA-UPR 2.4PA - for 24V DC – for ambient temperature -60°C do +40°

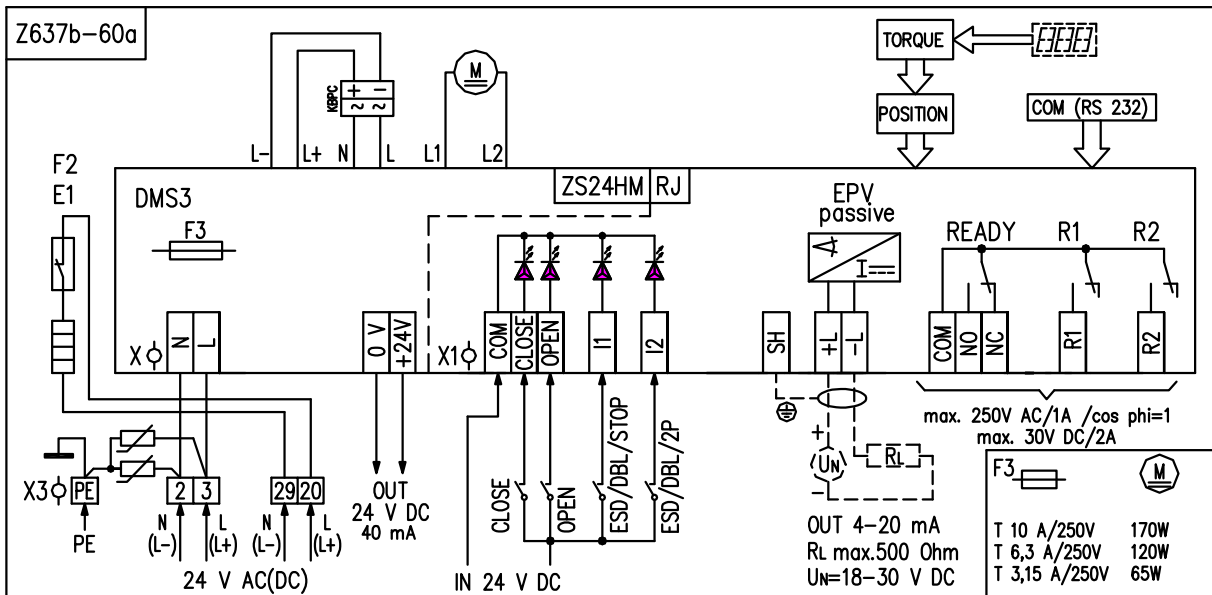
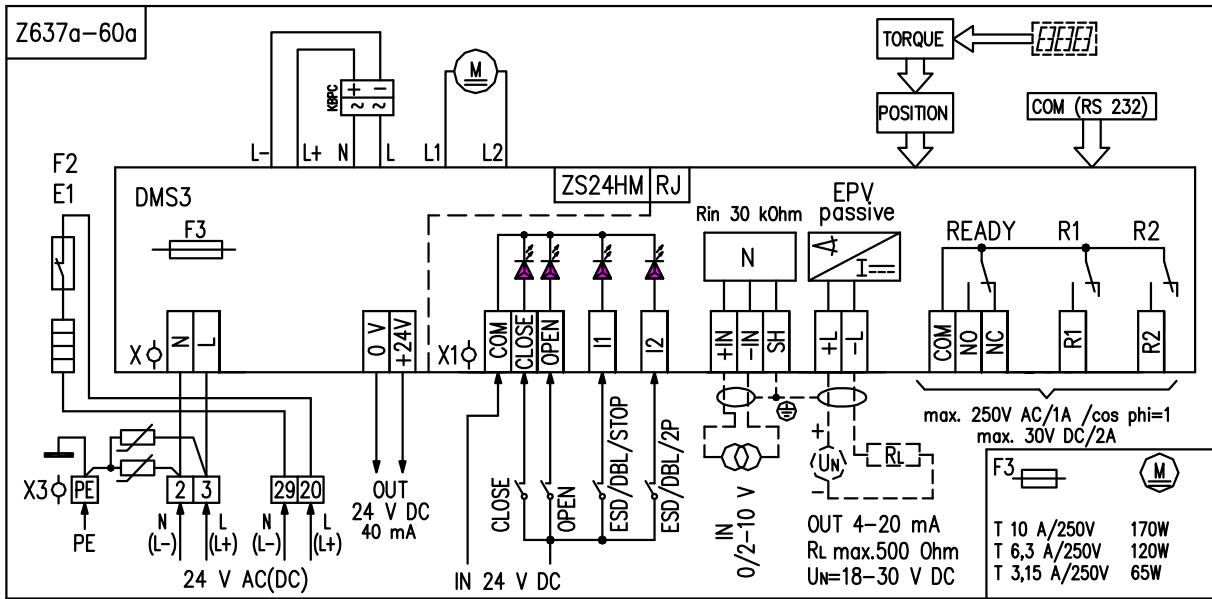
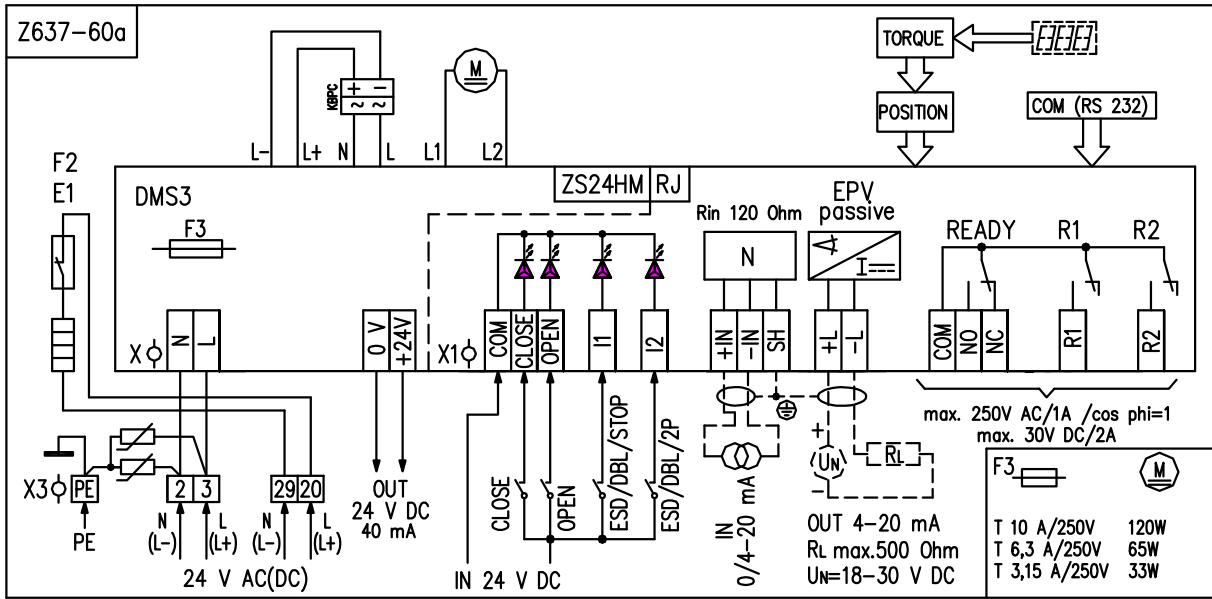

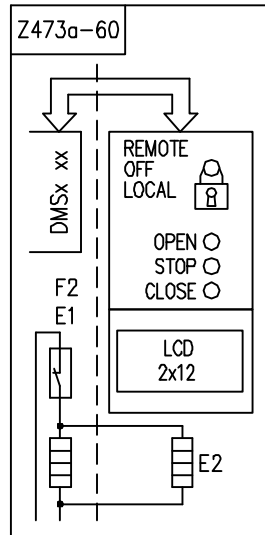
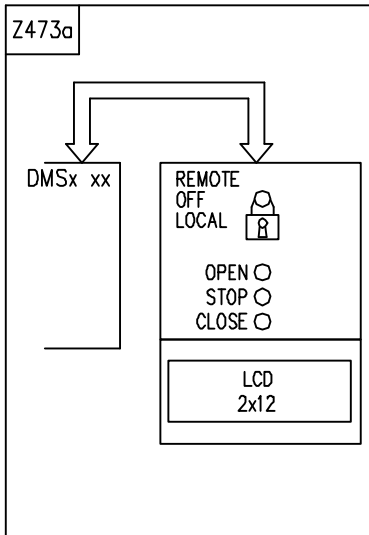
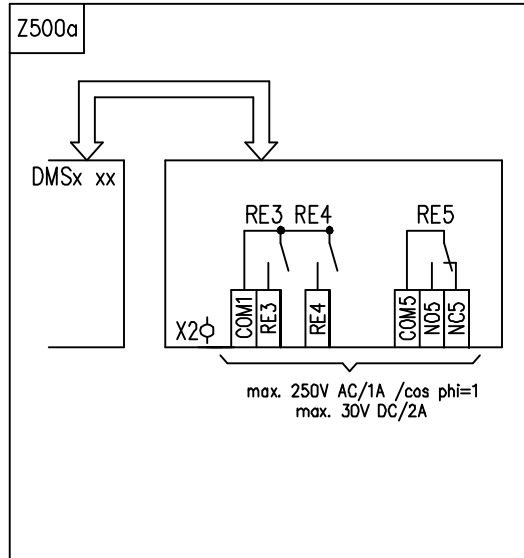
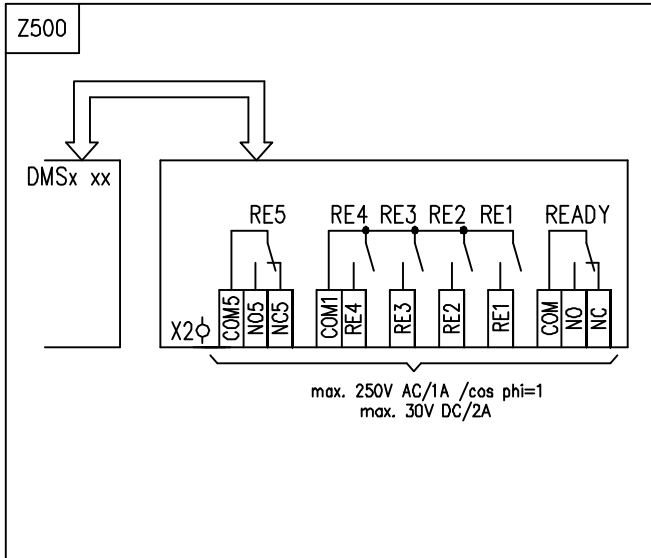

Legend:

Note: The legend to the wiring diagrams Zxxx (eg Z574c-60a) is identical with wiring diagrams with connection to connector ZKxxx (eg ZK574cc).

- Z473a.....wiring diagram of electric local control
 Z500.....wiring diagram module with 6 additional relays
 Z500a.....wiring diagram module with 3 additional relays
 Z514.....wiring diagram of EA with 1-phase electric motor for the ON/OFF control or for analogue input 0/4/12 up to 20 mA, 4 up to 12 mA and output signal 4 - 20 mA
 Z515.....wiring diagram of EA with 1-phase electric motor for the ON/OFF control
 Z523.....wiring diagram of EA with 1-phase electric motor for the ON/OFF control or for analogue input 0/2 - 10 V and output signal 4 - 20 mA
 Z532.....wiring diagram of EA UPR 1PA with 3-phase electric motor for the ON/OFF control or for analogue input 0/4/12 to 20 mA, 4 to 12 mA and output signal 4 - 20 mA
 Z536.....wiring diagram of EA UPR 1PA with 3-phase electric motor for the ON/OFF control or for analogue input 0/2 - 10 V and output signal 4 - 20 mA
 Z537.....wiring diagram of EA UPR 1PA with 3-phase electric motor for the ON/OFF control
 Z532b.....wiring diagram of EA UPR 2PA with 3-phase electric motor with contactors for the ON/OFF control or for analogue input 0/4/12 to 20 mA, 4 to 12 mA and output signal 4 - 20 mA
 Z536b.....wiring diagram of EA UPR 2PA with 3-phase electric motor with contactors for the ON/OFF control or for analogue input 0/2 - 10 V and output signal 4 - 20 mA
 Z537b.....wiring diagram of EA UPR 2PA with 3-phase electric motor with contactors for the ON/OFF control
 Z532f.....wiring diagram of EA UPR 2PA-UPR2.4PA with 3-phase electric motor with contactless switching for the ON/OFF control or for analogue input 0/4/12 to 20 mA, 4 to 12 mA and output signal 4 - 20 mA
 Z536f.....wiring diagram of EA UPR 2PA-UPR2.4PA with 3-phase electric motor with contactless switching for the ON/OFF control or for analogue input 0/2 - 10 V and output signal 4 - 20 mA
 Z537f.....wiring diagram of EA UPR 2PA-UPR2.4PA with 3-phase electric motor with contactless switching for the ON/OFF control
 Z637.....wiring diagram of EA with direct voltage for the ON/OFF control or for analogue input 0/4/12 to 20 mA or 4 to 12 mA and output signal 4 - 20 mA – 24 V AC/DC
 Z637a.....wiring diagram of EA with direct voltage for the ON/OFF control or for analogue input 0/2 - 10 V and output signal 4 - 20 mA
 Z637b.....wiring diagram of EA with direct voltage for the ON/OFF control
- C.....capacitor
 COM(RS232) ...possibility for connecting the control unit to and PC
 EPV passive ...electronic position transmitter is passive with output current signal
 E1.....space heater
 F1.....motor`s thermal protection (not valid for UPR 1PA)
 F3.....fuse of voltage supply source
 KM1, KM2coil of contactor
 K1,K2coil of relay
- M.....single phase electric motor
 N.....controller
 POSITION.....position scanning
 R_{in}input resistance
 R_Lload resistance
 U_Nvoltage for EPV
 READY.....READY relay (free-programmable)
 R1 to RE5additional relays
 TORQUEthrust scanning
 DMS3.....electronic module
- X.....voltage supply source terminal board with screw terminals
 X1.....terminal board with screw terminals on the control unit
 X2.....screw terminal box on the additional relays board
 X3.....screw terminal of supply 3-phase motor

Terminals:

PE, N, L - terminals (0,05-1,5 mm²) of supply (24 V AC resp. 110/120 V AC, resp. 220/230 V AC, 50/60 Hz (according to the specification – voltage and frequency are stated on nameplate of EA)

2, 3, 4 – terminals (0,08-2,5 mm²) of supply 3-phase motor 3x400 resp. 3x380 V AC

5,6 - terminals (0,08-2,5 mm²) wired motor/s thermal protection

OP, CL - terminals (0,08 - 2,5 mm²) of the outputs of the direction rotations of the electric actuators > (220/230 V AC)

0 V, +24 V – terminals (max. 1,5 mm²) of output voltage 24 V DC (40 mA)

COM, CLOSE OPEN, I1, I2 – terminals (0,05 - 1 mm²) of control inputs 24 V /DC

+IN, -IN, SH – terminals (0,05 - 1 mm²) of analogue input signal 0/4/12 up to 20 mA, resp. 4 up to 12 mA

+L, -L, SH – terminals (0,05 - 1 mm²) of output current signal (passive) 4-20 mA

COM, NO, NC – terminals (0,05 – 1,5 mm²) of relay READY

COM, NO – terminals (0,05 – 1,5 mm²) of relay R1, R2

COM 1, RE3, RE4 - terminals (0,05 – 1,5 mm²) of relay RE3, RE4

COM5, NO5, NC5 – terminals (0,05 - 1,5 mm²) of relay RE5 (on the module of the additional relays)

Terminals for DMS3 24 V AC/DC:

2, 3 – terminals (0,08 - 2,5 mm²) of supply 24 V AC/DC

0 V, +24 V – terminals (max. 1 mm²) of output voltage 24 V DC (40 mA)

COM, CLOSE OPEN, I1, I2 – terminals (0,05 - 1 mm²) of control inputs 24 V DC

+IN, -IN, SH – terminals (0,05 - 1 mm²) of analogue input signal 0/4/12 až 20 mA, resp. 4 až 12 mA

+L, -L, SH – terminals (0,05 - 1 mm²) of output current signal (passive) 4-20 mA

COM, NO, NC, R1, R2 – terminals (0,05 - 1,5 mm²) READY relay, R1 and R2 relay on control unit

COM5, NO5, NC5 – terminals (0,05 – 1,5 mm²) relay R1, R2 (on module of the additional relays)

COM1, RE4, RE3, RE2, RE1 - terminals (0,05 – 1,5 mm²) of relay RE3, RE4 (on module of the additional relays)

COM, NO, NC – terminals (0,05 – 1,5 mm²) relay RE5 (on module of the additional relays)

Note 1: On terminal N, L terminal power supply (X) feed supply voltage 230 V AC, or 24 V AC by you - specified type of construction EA. For supply voltage 24 V AC no need connect ground wire PE. For a version of EA with the supply voltage 3x400 or 3x380V, terminals N, L on terminal board of power supply (X) are fed by power supply 220 respectively 230 V AC.

Note 2: Three-phase electric motor in the electric actuators UPR 1PA do not have thermal protection of the electromotor F1 wired to terminals 5 and 6 (thermal protection of the electric motor is inbuilt).

Thermal protection wired to the terminals 5 and 6 is offered only for 3-phase electric motor of the electric actuators UPR 2PA, UPR 2.4PA, UPR 2.5PA.

*Note 3: Program possibilities for **R1, R2, RE3, RE4, RE5** relays: DISABLED, open position, close position, torque-open, torque – close, torque open or torque close, torque open or position open, torque close or position close, open, close, movement, movement flasher, to position, from position, warning, remote control, local control, control shut off.*

*Program possibilities for **READY** relay: errors, errors or warnings, errors or no remote, errors or warnings or no remote.*

*Program possibilities for output signal (from **EPV** passive): 4 to 20 mA, 20 to 4 mA.*

Control programme options (regulating): 2P, 3P, 3P/2P switched over to I2

*Program possibilities for **input control signal (N)**: 4 to 20 mA (2 to 10 V), 20 to 4 mA (10 to 2 V), 0 to 20 mA (0 to 10 V), 20 to 0 mA (10 to 0 V).*

*Program possibilities for **inputs I1**: DISABLED, ESD, DBL (local releasing, remote releasing - not valid for EA without local control), STOP.*

*Program possibilities for **inputs I2**: DISABLED, ESD, DBL (local releasing, remote releasing), STOP 2P (when controller is switch on)(for control programme option 3P/2P I2)) allows control using the binary 24V DC inputs with I2 input activated.*

*Program possibilities of **FAILURE REACTION**: OPEN, CLOSE, STOP, SAFE POSITION.*

The identical functions cannot be set on I1 & I2 inputs in addition to the disabled state (e.g., if the ESD function is set on I1 input, it is not possible to select the (ESD) function on I2 input at the same time.

*Relay **READY** on the control unit is doubled with relay **READY** on the power supply board.*

*Relay **R1** and relay **R2** on the control unit is doubled with relay **RE1** and relay **RE2** on the power supply board.*

7.2 Dimensional drawings

Electric part-turn actuators Rematic UPR 1PA, UPR 2PA

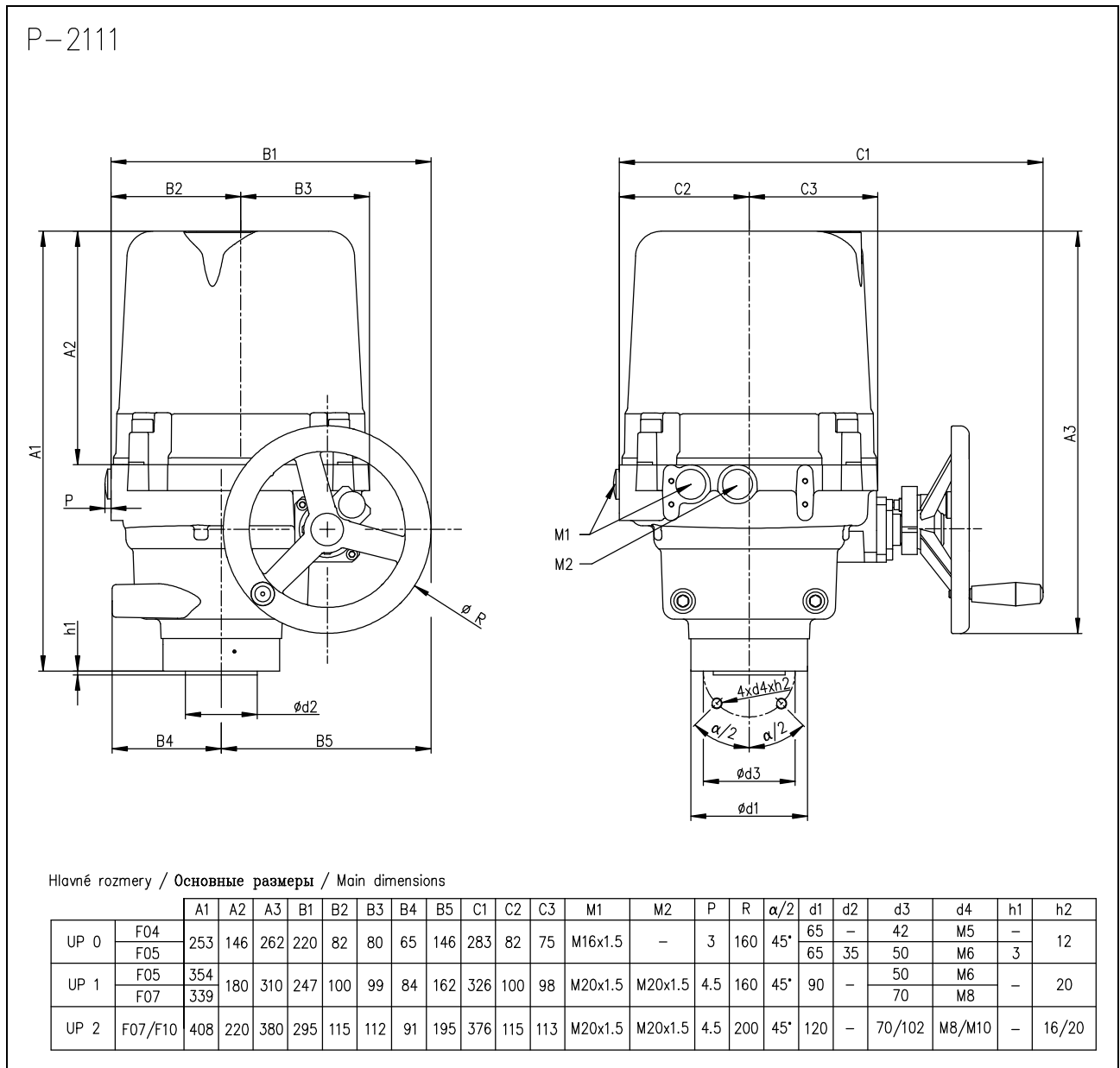

Electric part-turn actuators **Rematic UPR 1PA, UPR 2PA** – version with stand + lever + pull-rod

P-2110

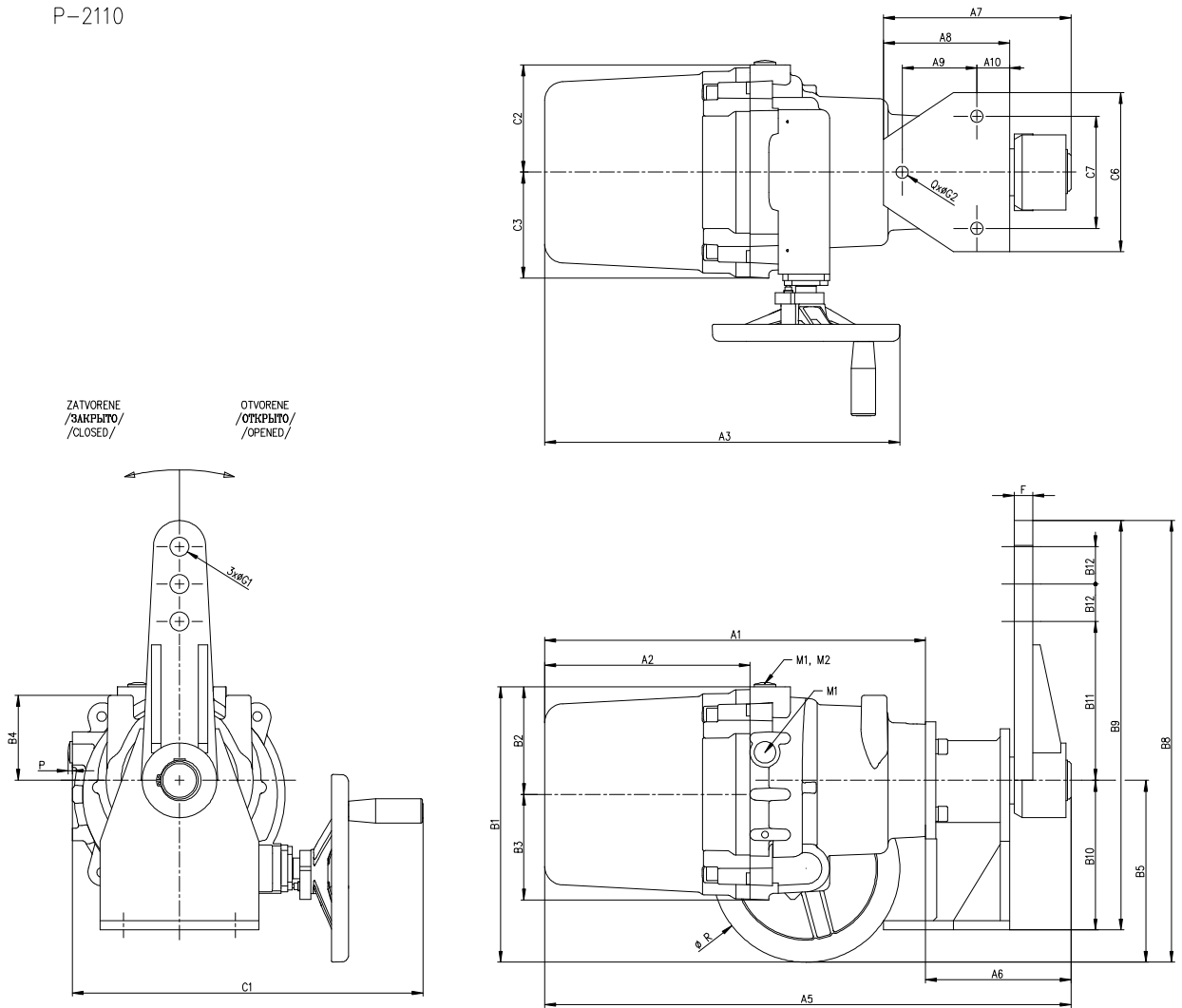

Hlavné rozmery / Основные размеры / Main dimensions

	A1	A2	A3	A5	A6	A7	A8	A9	A10	B1	B2	B3	B4	B5	B8	B9	B10	B11	B12	C1	C2	C3	C6	C7	F	G1	G2	M1	M2	P	Q	R
UP 0	253	146	262	309	56	86	50	—	38	220	82	80	65	146	241	335	160	120	20	283	82	75	130	80	14	13	10.5	M16x1.5	—	3	2	160
UP 1	339	180	310	404	65	95	58	—	28	247	100	99	84	162	337	375	200	120	20	326	100	99	160	90	14	13	12.6	M20x1.5	M20x1.5	4.5	2	160
UP 2	408	220	380	564	156	201	135	80	35	295	115	113	91	195	473	438	160	170	40	376	115	113	170	120	20	20	13	M20x1.5	M20x1.5	4.5	3	200

Electric part-turn actuators **Rematic UPR 1PA, UPR 2PA** with local control

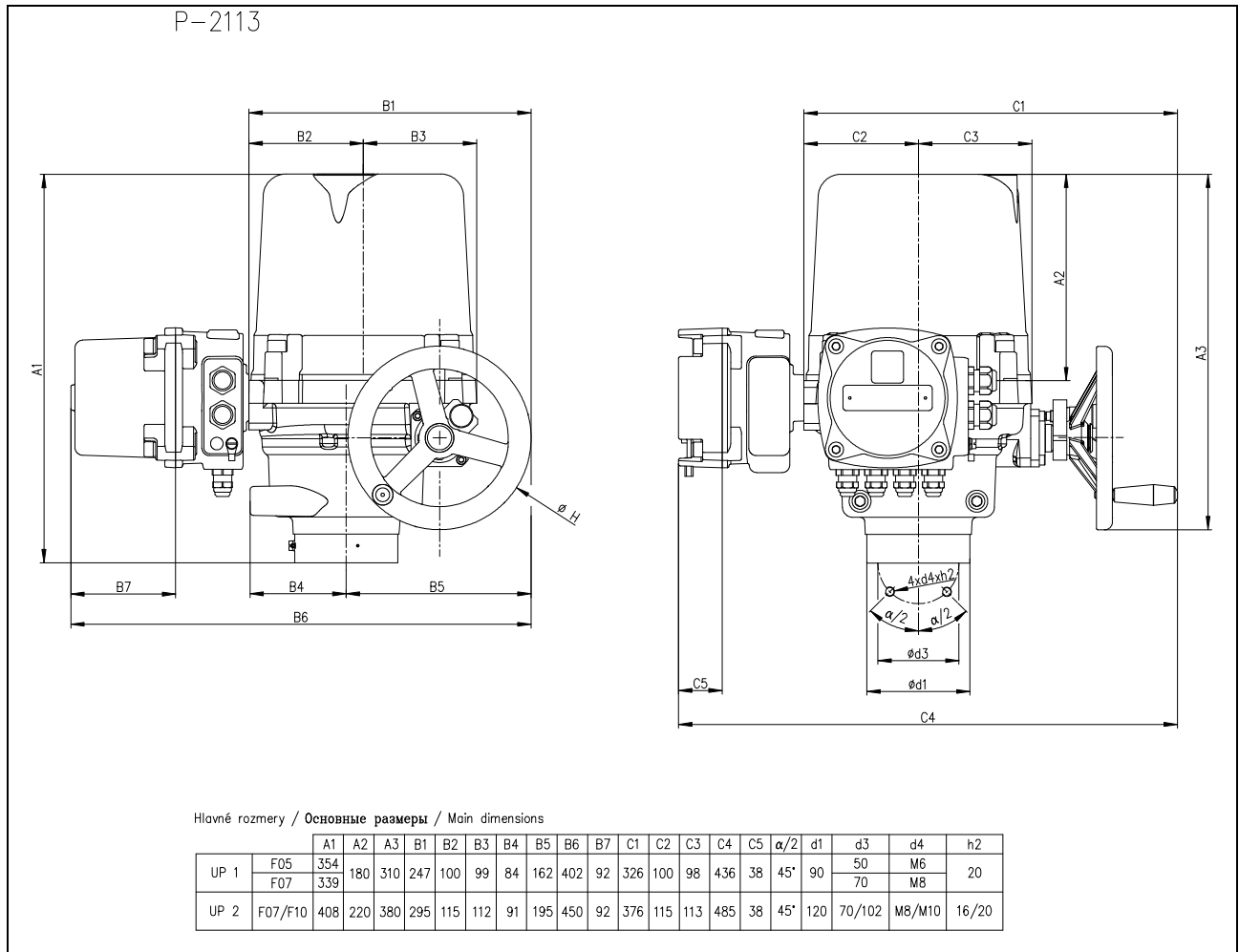

Electric part-turn actuators **Rematic UPR 1PA, UPR 2PA** with local control, stand and lever

P-2116

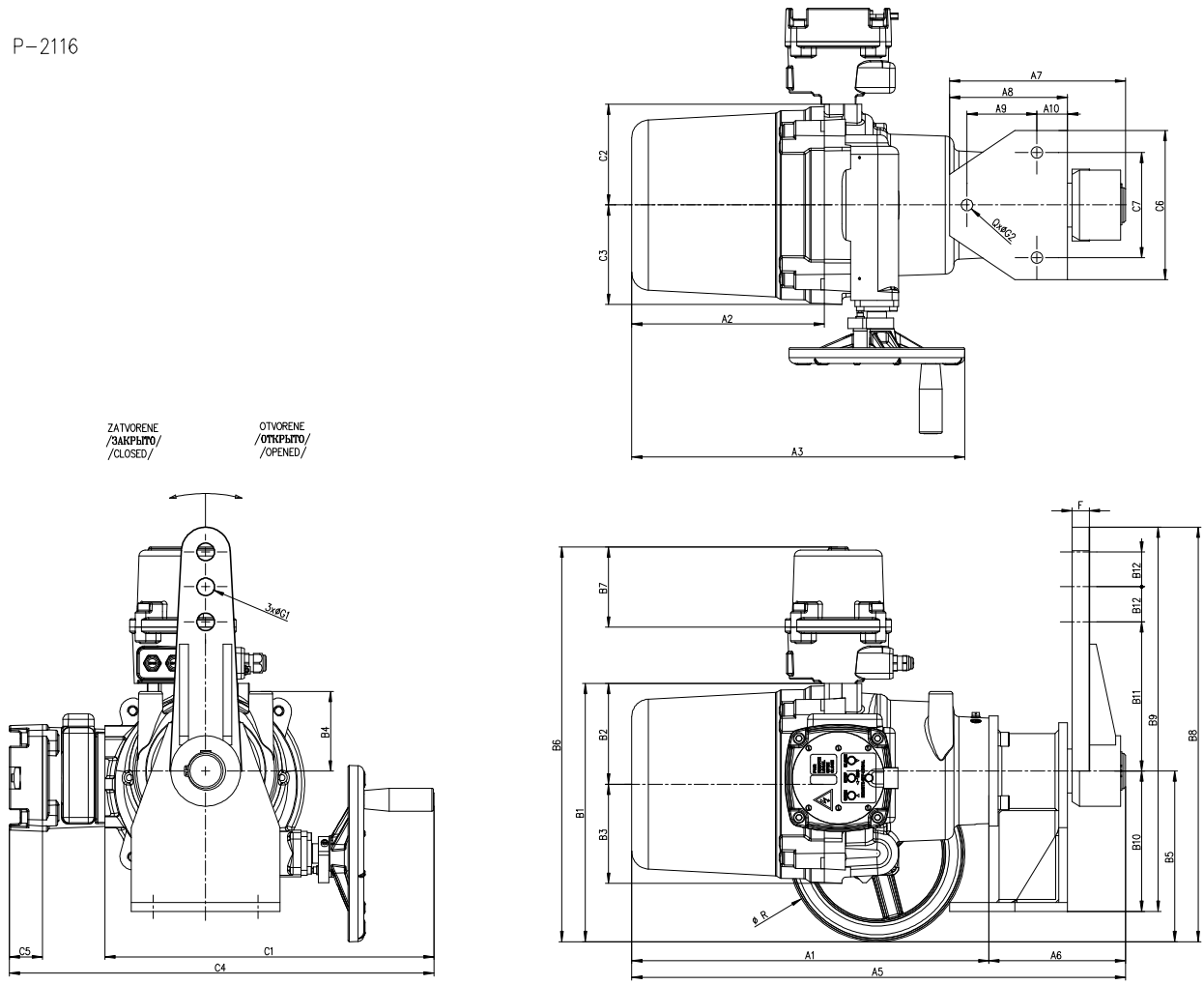

Hlavné rozmery / Основные размеры / Main dimensions

	A1	A2	A3	A5	A6	A7	A8	A9	A10	B1	B2	B3	B4	B5	B6	B7	B8	B9	B10	B11	B12	C1	C2	C3	C4	C5	C6	C7	F	G1	G2	Q	R
UP 1	339	180	310	404	65	95	58	-	28	247	100	99	84	162	402	92	337	375	200	120	20	326	100	99	436	38	160	90	14	13	12.6	2	160
UP 2	408	220	380	564	156	201	135	60	35	295	113	113	91	195	450	92	473	438	160	170	40	376	115	113	485	38	170	120	20	20	13	3	200

Electric part-turn actuators **Rematic UPR 2.4PA, UPR 2.5PA**

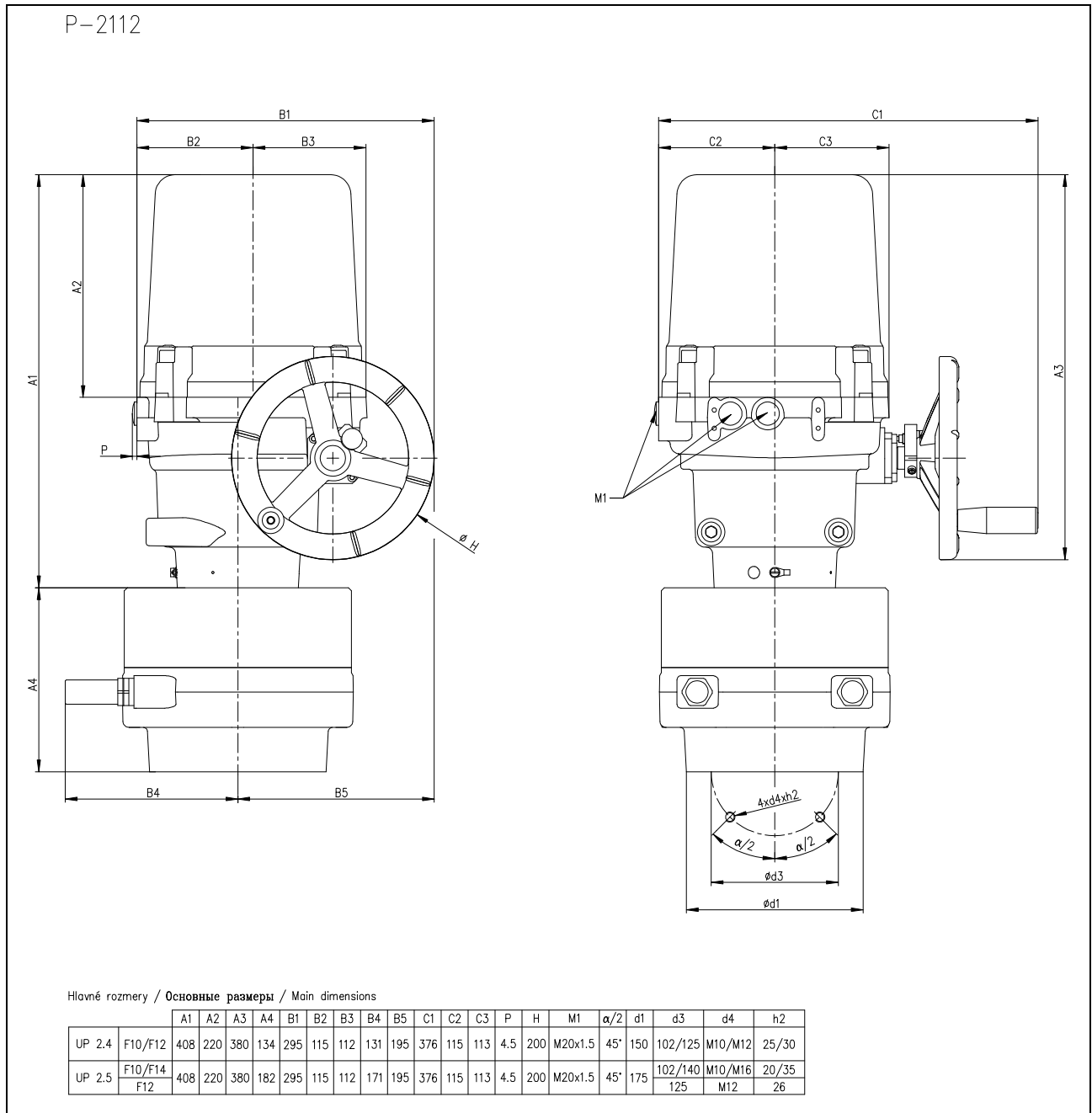

Electric part-turn actuators **Rematic** – version with stand and lever

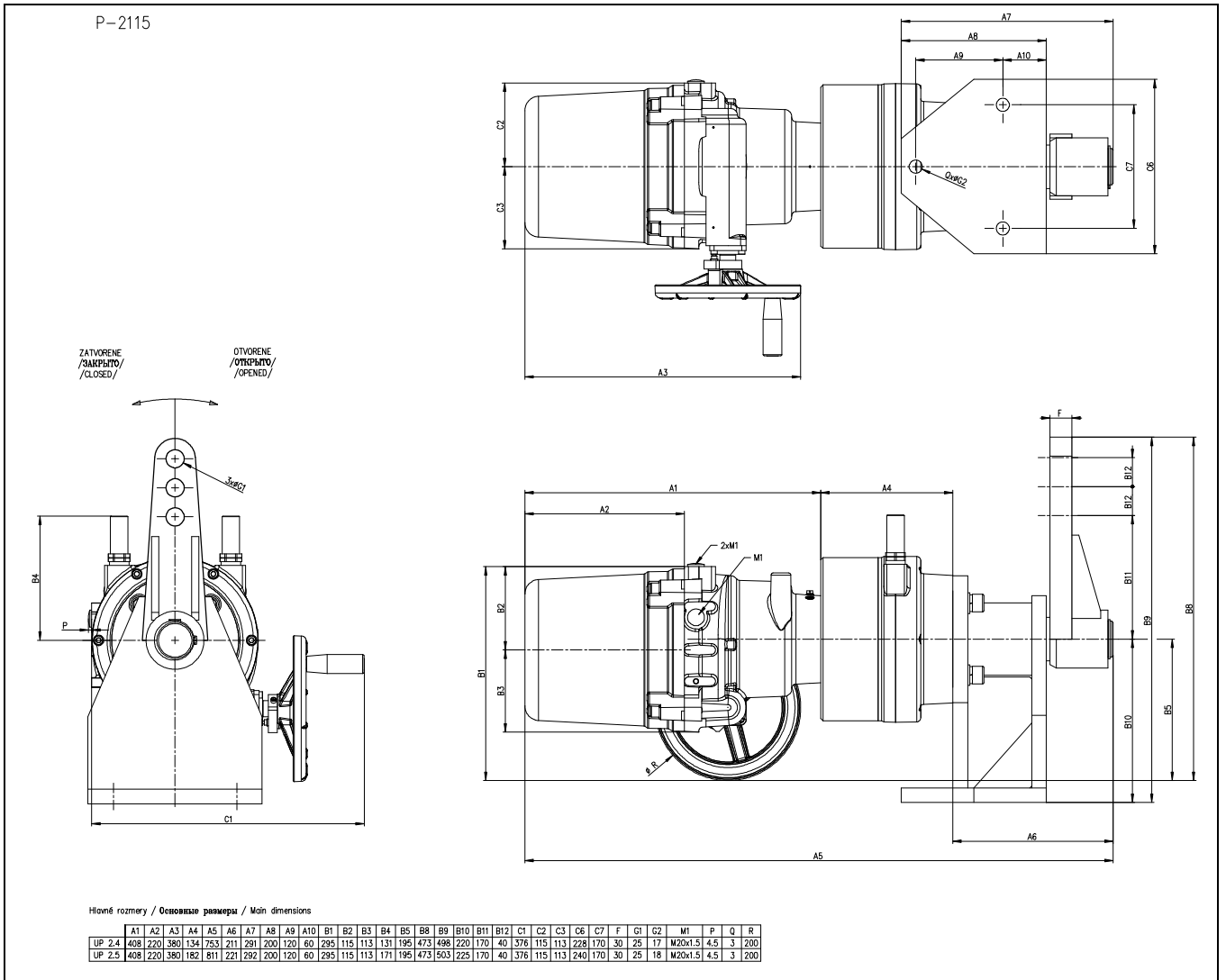

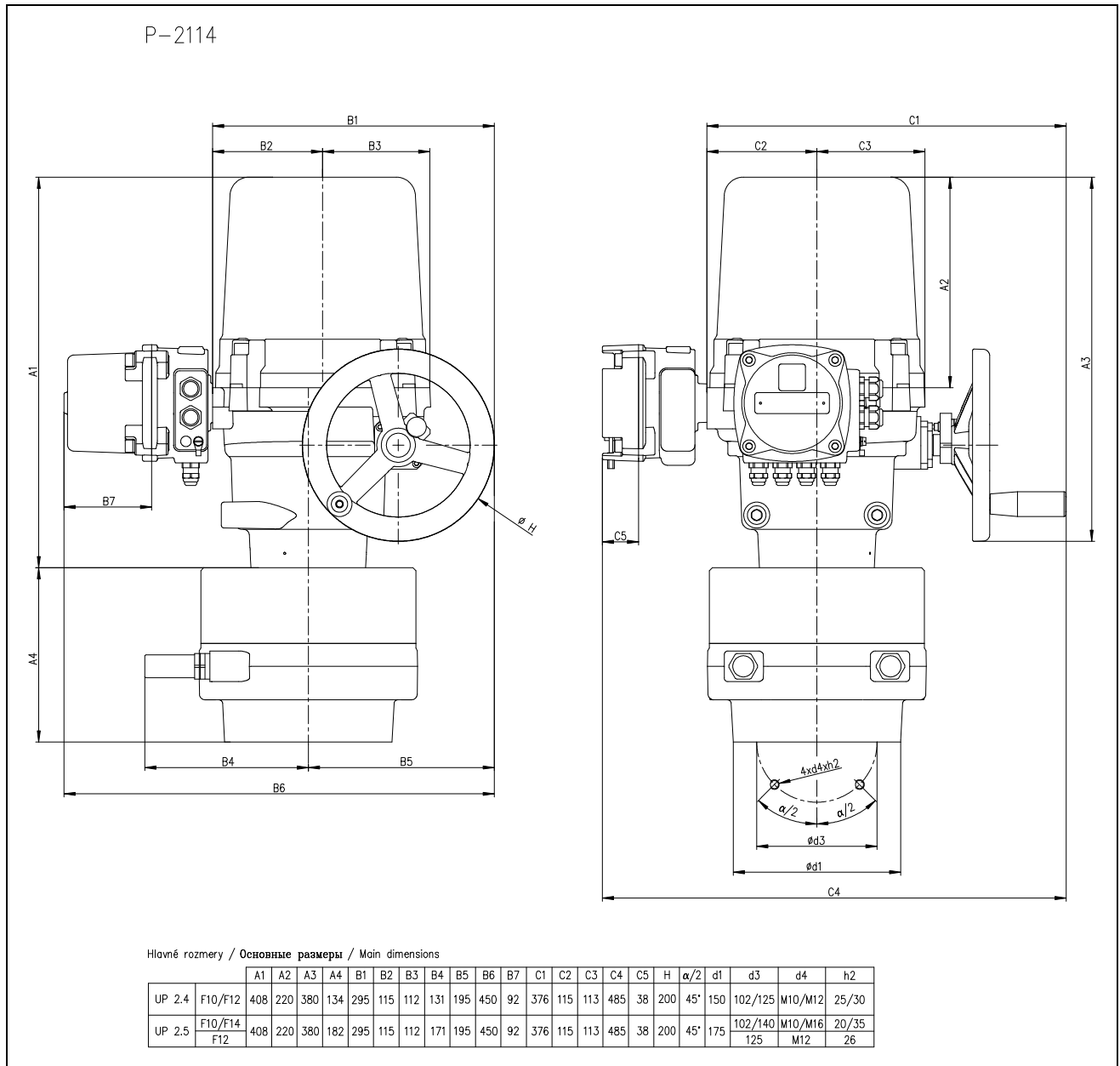

Elektrický servopohon jednotáčkový Unimact **UPR 2.4PA, UPR 2.5PA** with local control

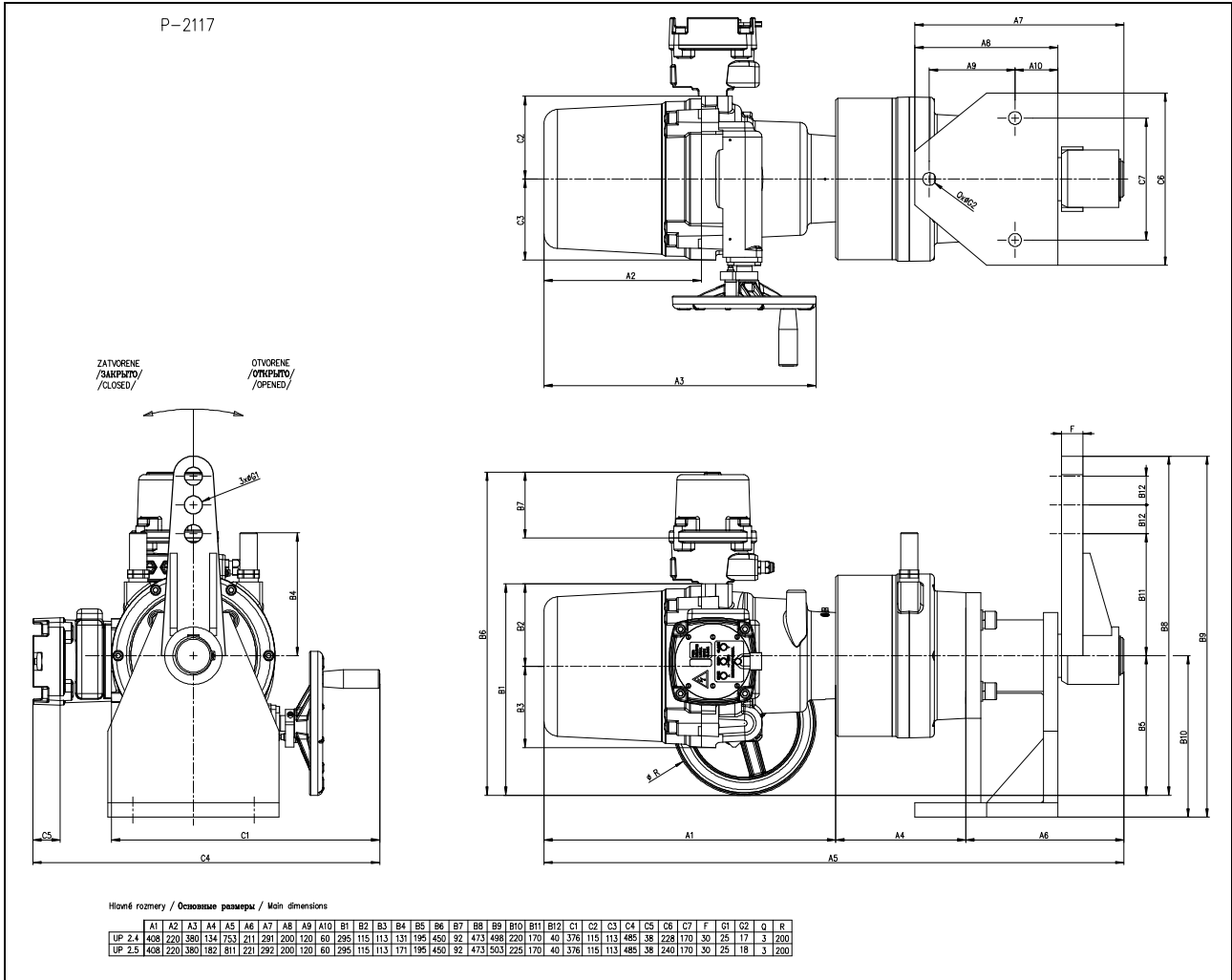

Elektrický servopohon jednotáčkový Unimact **UP 2.4, UP 2.5** with local control, stand and lever

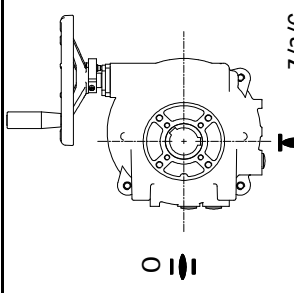
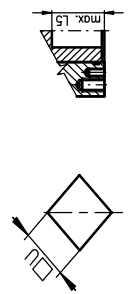
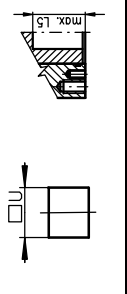
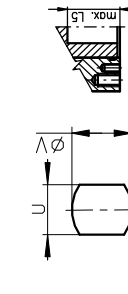

TVAR PRIPOJUVANCIENO DIELSA PREES/ ФОРМА ПРИСОЕДИНИТЕЛЬНОЙ ДЕТАЛИ/ COUPLING SHAPE

	UP 0			UP 1			UP 2			UP 2.4			UP 2.5		
	U	L5		U	L5		U	L5		U	L5		U	L5	
	D-9	9		D-9	9		D-14	14		D-11	11		D-22	22	
	D-11	11	36	D-11	11		D-17	17	49	D-14	14		D-27	27	70
	D-14	14		D-12	12	37.5	D-19	19		D-16	16		D-36	36	
				D-14	14		D-22	22		D-17	17				
	L-9	9		L-9	9		L-14	14		L-11	11		L-22	22	
	L-11	11	36	L-11	11		L-17	17	49	L-14	14		L-27	27	70
	L-14	14		L-12	12	37.5	L-19	19		L-16	16		L-36	36	
				L-14	14		L-22	22		L-17	17				
	H-8	8	13	H-8	8	13	H-13	13	19	H-8	8	13	H-22	22	32
	H-9	9	14	H-10	10	16	H-14	14	22	H-10	10	16	H-27	27	48
	H-11	11	14	H-11	11	18	H-17	17	36	H-11	11	18	H-36	36	48
	H-11	11	18	H-13	13	19	H-19	19	28	H-13	13	19			
	V-12	12	13,6	4	V-17	17	19,5	6	V-17	17	19,5	6	V-42	42	45,1
	V-14	14	16,1	5	V-18	18	20,5	6	V-18	18	20,5	6	V-50	50	53,5
	V-18	18	20,6	6	V-20	20	22,5	6	V-22	22	24,9	8	V-48	48	51,5
					V-30	30	32,5	8	V-28	28	30,9	8	V-60	60	64,4
								V-36	36	39,3	10	V-28	28	30,9	8
								V-42	42	45,3	12	V-30	30	32,5	8
												V-32,2	32,2	35	6,5
												V-42	42	45,1	12
												V-45,4	45,4	48,8	10
												V-50	50	53,5	14

Pull-rod dimensions TV 160 (P-0100)

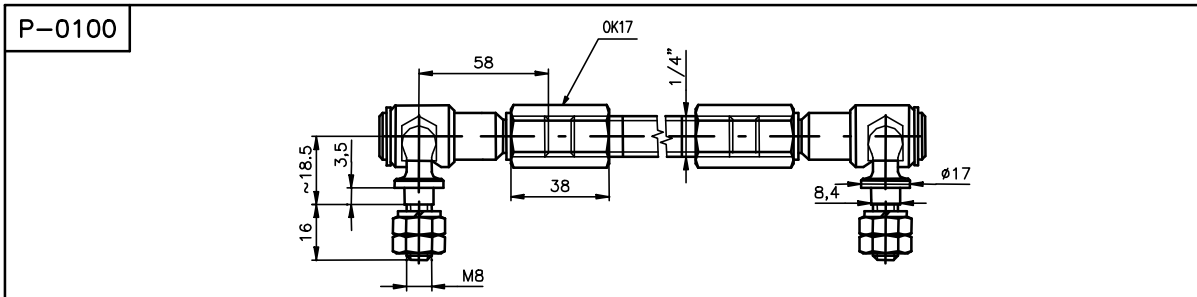

Pull-rod dimensions TV 360 (P-0210)

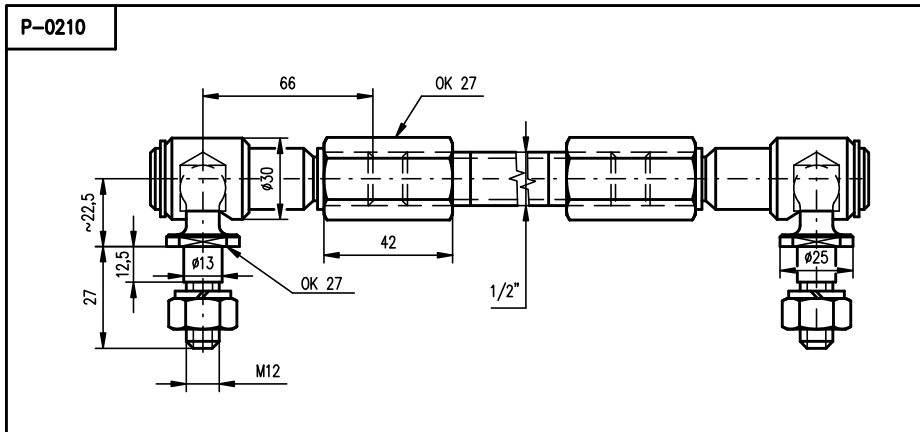

Rozmery ťahadla TV 40-1/20 a TV 50-1/25

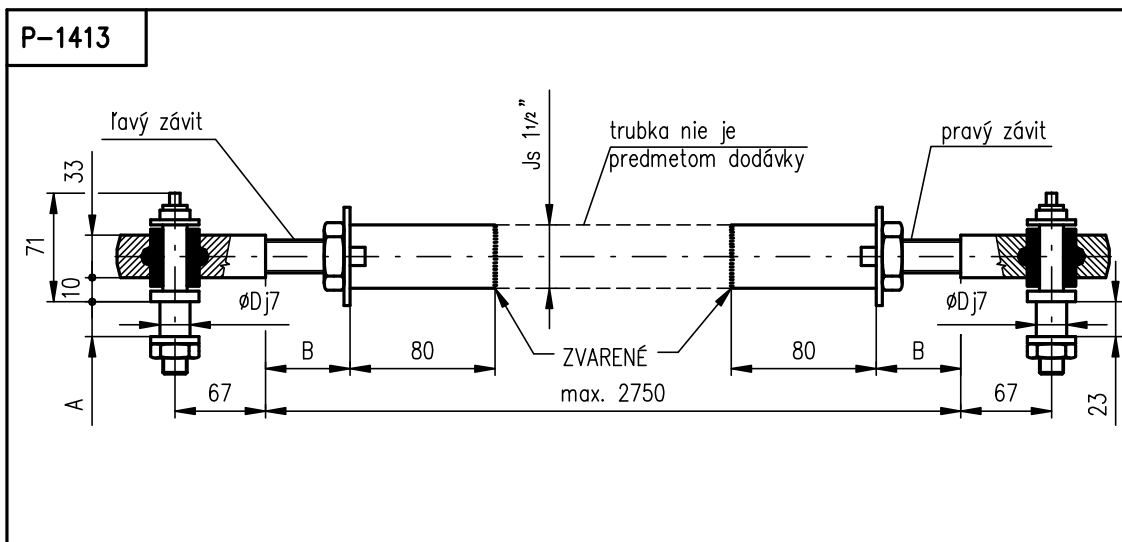

P-1413/B	TV 50-1/25	28	min.30 max.50	25
P-1413/A	TV 40-1/20	23		20
VYHOTOVENIE/ VERSION	TYP ŤAHADLA/ PULL - ROD VERSION	A	B	D

Mechanical connection stand + output shaft with key

P-2118		COUPLING SHAPE								
Tvar / Type SV-xx		Typ/Type	H	S	U	V	Z	Y	Y1	Coupling shape
		UXX 0XX	24,5	22	6	28	25	2	2	SV-22
		UXX 0.1XX	24,5	22	6	28	25	2	2	SV-22
		UXX 1XX	27,9	25	8	35	28	2	2	SV-25
		UXX 2XX	43,1	40	12	66	56	4	7	SV-40
		UXX 2.4XX	53,8	50	16	82	70	4	7	SV-50
		UXX 2.5XX	64,4	60	18	84	70	4	7	SV-60

7.3 Guarantee service check report

Service center:	
Date of repair:	Guarantee repair no.:
User of actuator:	Claim applied by:
Actuator type number:	Actuator production number:
Product claim fault:	Detected product fault:
Used spare parts:	
Remarks:	
Issued on a day:	Signature:

7.4 Post guarantee service check report

Service center:	
Date of repair:	
User of actuator:	Actuator operating place :
Actuator type number:	Actuator production number:
Detected product fault:	
Used spare parts:	
Remarks:	
Issued on a day:	Signature:

7.5 Commercial representation

Slovak Republic:

Regada, s.r.o.,
Strojnícka 7,
080 01 Prešov
Tel.: +421 (0)51 7480 460,
Fax: +421 (0)51 7732 096,
E-mail: regada@regada.sk